

# ***Submersible Inclinomometer***

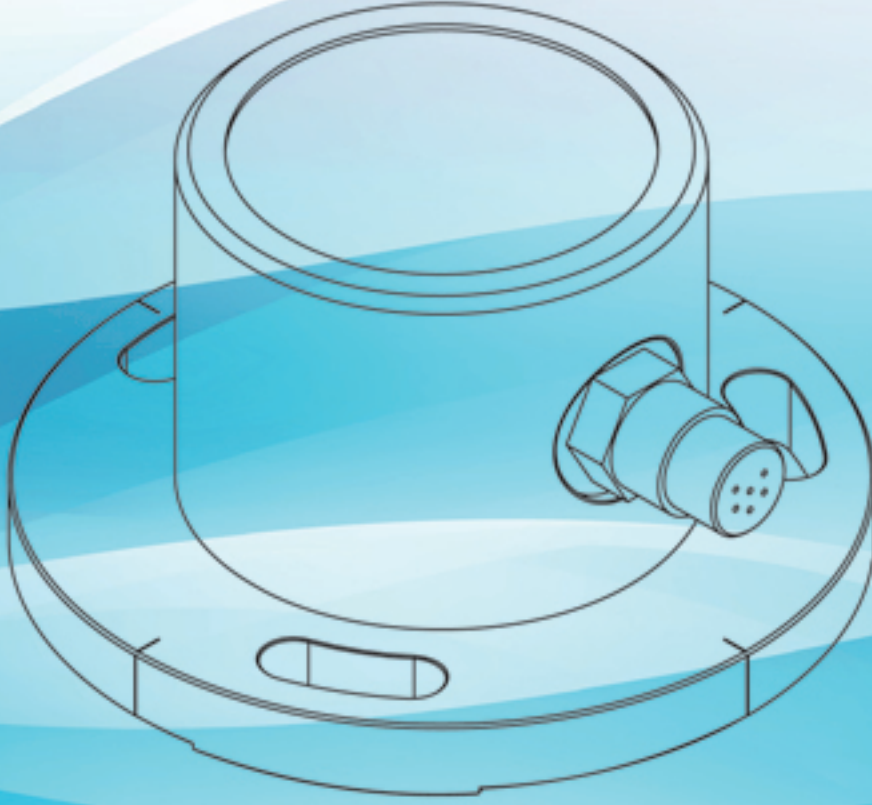

# Submersible Inclinometer

## Features

- 3000m submersible depth
- Combined accuracy:  $\pm 0.01^\circ$
- $\pm 0.1\%$ FS Cross-axis sensitivity
- Special underwater connector
- Resistance to acid and alkali salt corrosion
- Reduce installation error via "Allowed Input axis misalignment"

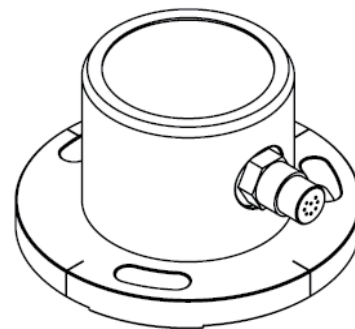

## Descriptions

Vigor's Submersible Inclinometer provides very high combined accuracy and real-time remote monitoring of tilt of submerged structures or slow moving object. A high-performance SST300 sensor mounted inside a rugged waterproof housing to under-water with max.3000m.

The inclinometer housing is machined and welded from solid stainless steel, each product meet with high-pressure test, to providing extreme endurance for long-term high-pressure underwater environment. The cable and socket is a submarine grade connector, which provides watertight performance at depths exceeding 3000 meters.

This unit provides  $\pm 0.1\%$ FS Cross-axis sensitivity and  $\pm 0.01^\circ$ Combined absolute accuracy. It is a real high performance product.

To resolve the difficult installation underwater, this unit performs a special parameter named as "Allowed Input axis misalignment" which can reduce the installation error more when the real tilt direction not consistent to unit sensitivity axis.

The inclinometer can be mounted directly on horizontal, vertical or inclined surfaces. In all three situations, no precision leveling or alignment of the inclinometer is required as the wide measurement range ( $\pm 60^\circ$ ) allows for latitude in installation.

## Dimensions (mm)

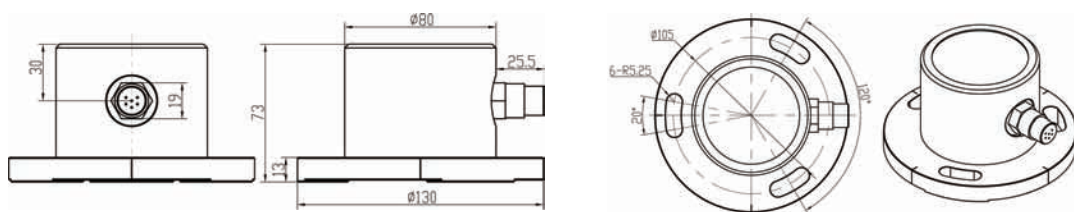

Picture 1 Housing with connector

## Wiring



Picture 2 Connector socket  
(View from outside)

Table 2 Socket Pin definition

Pin	RS485 output	CAN
1	Power+	Power+
2	Power-	Power GND
3	Signal GND	NC
4	NC	CANH
5	NC	CANL
6	RS485A	NC
7	RS485B	NC
8	NC	NC

## Performances

Table 1 Specifications

Measurement range	±5°	±10°	±15°	±30°	±45°	±60°	
Combined absolute accuracy <sup>①</sup> (@25 °C)	±0.01°	±0.015°	±0.02°	±0.04°	±0.06°	±0.08°	
Accuracy subroutine parameter	Absolute linearity (LSF,%FS)	±0.06	±0.03	±0.03	±0.03	±0.02	±0.02
	Cross-axis sensitivity <sup>②</sup>	±0.1%FS					
	Offset <sup>③</sup>	±0.005°			±0.008°		
	Repeatability	±0.0025°					
	Hysteresis	±0.0025°					
Allowed installation misalignment <sup>④</sup>	±4.0°	±3.0°	±2.5°	±1.5°	±1.2°	±1.2°	
Input-axis mislignment	≤±0.1°						
Sensitivity temperature drift coefficient(max.)	≤100ppm/°C		≤50ppm/°C				
Offset temperature drift Coefficient(max.)	≤0.003°/°C						
Offset turn on repeatability <sup>⑤</sup>	±0.008°						
Resolution	0.0025°						
Long-term stability(1 year) <sup>⑥</sup>	≤0.02°						
Measurement axis	1 or 2 axis						
Temperature sensor	Range: -50~125°C ,Accuracy: ±1°C						
Output	RS485, CAN						
RS485 data format	4800 baud, 8 data bits, 1 start bit, 1 stop bit, none parity, ASCII						
Cold start warming time	60s						
Response time <sup>⑦</sup>	0.3s(@t <sub>90</sub> )						
Refresh rate(digital output)	5Hz(optional 10Hz,20Hz)						
Power supply	9~36VDC						
Power consumption	Average working current≤50mA, average power≤1.5W(25°C &24VDC)						
Operation temperature range	-40~85°C						
Storage temperature range	-60~100°C						
EMC	According to EN 61000						
Insulation resistance	100MΩ						
MTBF	≥25000 h/times						
Shock	100g@11ms,three-axis, half- sine						
Vibration	8grms, 20~2000Hz						
Protection	3000m underwater						
Connecting	3000m underwater with Subconn <sup>®</sup> plug						
Weight	3Kg(without connector and cable)						

① Combined absolute accuracy means the compositive value of sensor's absolute linearity, repeatability, hysteresis, offset and cross-axis sensitivity error. (in room temperature condition) as

$$\Delta = \pm \sqrt{\text{absolute linearity}^2 + \text{repeatability}^2 + \text{hysteresis}^2 + \text{offset}^2 + \text{cross-axis sensitivity error}^2}$$

② The cross-axis sensitivity means the angle that the tilt sensor may be banked to the normal tilt direction of sensor. The cross-axis sensitivity (±0.1%FS) shows how much perpendicular acceleration or inclination is coupled to the inclinometer output signal. For example, for the single-axis inclinometer with range ±30°(assuming the X-axis as measured tilt direction), when there is a 10° tilt angle perpendicular to the X-axis direction(the actual measuring angle is no change, example as +8.505°), the output signal will generate additional error for this 10° tilt angle, this error is called as cross-axis sensitivity error. SST300's cross-axis sensitivity is 0.1%FS, the extra error is 0.1%×30°=0.03°(max), then real output angle should be +(8.505°±0.03°). In SST300 series, this error has been combined into the absolute accuracy

③ Offset means that when no angle input (such as the inclinometer is placed on an absolute level platform), output of sensor is not equal to zero,the actual output value is zero offset value.

④ Allowed installation misalignment means during the installation, the allow able installation angle deviation between actual tilt direction and sensor's nature measurement direction. In general, when installed,SST300 sensor is required that the measured tilt direction keep parallel or coincident with sensor designated edge, this parameter can be allowed a certain deviation when sensor is installed and does not affect the measurement accuracy.

⑤ Offset turn on repeatability means the repeatability of the sensor in repeated by supply power on-off-on many times.

⑥ Long-term stability means the deviation between the statistics of the maximum and the minimum output value after a year of continuous power supply when the sensor is at 20°C .

⑦ The response time refers to the angle sensor in a step change (such as the angle changes from -10 ° to +10 °within 5ms), the time required that output of the sensor achieved to the standard value of 90%. The index is different from the sensor set-up time

## Ordering

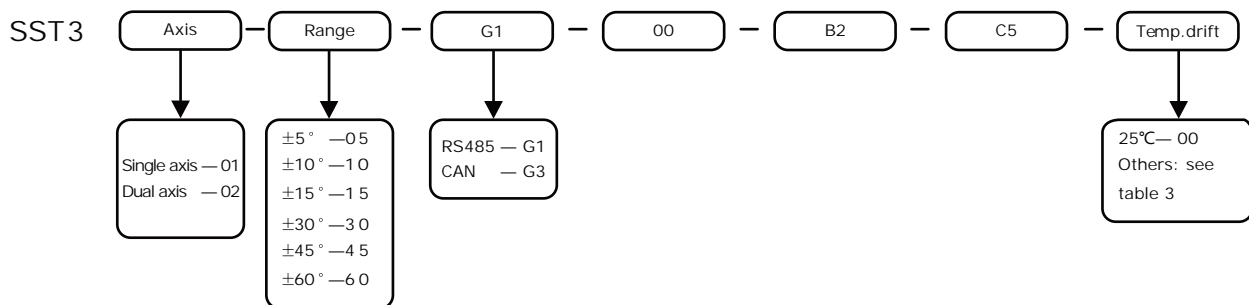

For example, if order a single axis inclinometer, with range  $\pm 15^\circ$ , Output RS485, Watertight cable with plug, vibration suppression function, 3000m underwater housing (B2), the model should be chosen as: SST301-15-G1-F5-B2-C5-00.

## Accessories & Options

Table 3 Accessories

Item	Order Code	Accessories name	Function
Output	G1	RS485 output	Standard industrial Modbus protocol
	G3	CAN output	Standard industrial interface
Cable/Plug	C5	Watertight cable with plug	3000m underwater with special plug
Temperature drift	D1	Temperature drift	Temperature compensation range is 0~60°C, accuracy $\pm 0.01^\circ @ \leq \pm 30^\circ$
	D2	Temperature drift	Temperature compensation range is 0~60°C, accuracy $\pm 0.01^\circ @ > \pm 30^\circ$

Table 4 Options

Item	P/N	Option name	Function
Display & Software	SST003-04-09	PC application software	Functions: serial port setting, control, diagnose, record, adjustable sampling, zero setting and zero recovery, adjustable vibration suppression filter parameters
	SST003-04-13	Flatness measuring software	Measure and display the surface flatness of object
	SST003-04-14	Verticality measuring software	Through multi-sensors, to realize the whole object's vertical measurement and display
Power	SST003-09-02	Portable battery packs	Output 24VDC, Continuous work 24 hours, IP65, rechargeable
	SST003-09-03	Complementary power combined with solar and wind energy	Solar and wind energy, output 24VDC@1A, Day & night working
Test report	SST003-11-01	Test report for cross-axis sensitivity	Sensitivity test report under banking tilt, average 11 points of full range
	SST003-11-03	Test report for Allowed Input axis misalignment	Axis migration test report for vertical and horizontal axis of inclinometer, 3 angles
	SST003-11-13	Test report for salt spray	According to MIL standard (meet MIL-810F 509.4)
	SST003-11-14	Test report for IP protection	According to IEC standard