

## User Manual

## English translation

### Correct Use

ZCode-TC is a coded tamperproofed magnetic safety switch with transistor output. It is simple to install, IP67 dust- and waterproofed and can switch with no contact. Anything other than the ZCode actuator will not trigger the switch. In combination with a Safety relay ( e.g. ZANDER SR-Series), a safety logic device (e.g. ZANDER MINOS) or a safety PLC (e.g. ZANDER TALOS) the switches are selfmonitoring with short-circuit protection. The stainless steel type ZCode-TCE is designed for rough and hygiene critical environments and applications.

### Features

- Coded sensor with switch indication LED - high degree of anti tamper.
- 2 non-contact safety outputs
- Compatible to all common safety logic devices
- Easy to install
- Wide tolerance to guard misalignment
- Fully sealed - IP67 Polymer housing, IP69K stainless steel housing
- Connect up to 3 switches to one ZANDER safety relay
- Up to PL e, Cat. 4 according to EN ISO 13849-1, Construction type 4 according to ISO 14119)
- ZCode Stainless Steel switches for applications in rough environments and high hygiene requirements, e.g. food, pharma and process industry (CIP, SIP cleaning)
- High operational life without moving or touching parts
- Super compact dimensions



### Function

Coded magnetic non contact safety switches ZCode are designed to interlock hinge, sliding or removal guard doors (see Fig. 1).

The outputs of the ZCode will be switch off, if the guard door is opened. The connected safety logic device will open the safety contacts.

The ZCode safety switches have a magnetic sensing system which provides a wide (> 10 mm) sensing distance and provides a high tolerance to misalignment after sensing. They can be fitted behind stainless steel fittings and can operate from 4 directions even in extreme environments (dusty and humid).



Figure 1: Application positions at protection device

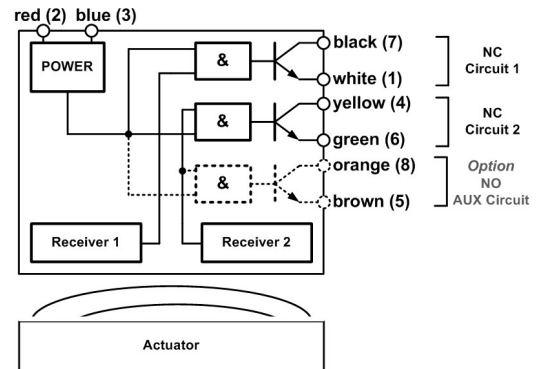

Figure 2: Block Diagram

### Mounting

M4 mounting bolts must be used to fix the switches and actuators. Tightening torque for mounting bolts to ensure reliable fixing is 2 Nm. Always mount on to non ferrous materials. The recommended setting gap is 5 mm.

The safety switches must not be used as a mechanical stop. The actuators must not be allowed to strike the switch. An adjustment by striking with a hammer is inadmissible. Do not mount adjacent switches or actuators closer than 30 mm. Typical misalignment tolerance after setting is 5 mm in any plane/direction (see Figure 3).

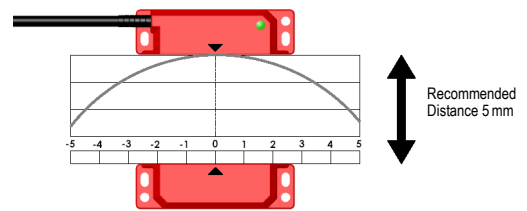

Figure 3: 5 mm misalignment tolerance after setting

### Safety Precautions



- Installation and commissioning of the device must be performed **only by authorized personnel**.
- Observe the country-specific regulations when installing the device.
- The electrical connection of the device is only allowed to be made with the device isolated.
- The wiring of the device must comply with the instructions in this user information, otherwise there is a risk that the safety function will be lost.
- It is not allowed to open the device, tamper with the device or bypass the safety devices.
- All relevant safety regulations and standards are to be observed.
- The overall concept of the control system in which the device is incorporated must be validated by the user.
- Failure to observe the safety regulations can result in death, serious injury and serious damage.
- The Risk Assessment for the particular application should include the risk of spare actuators. Spare actuators should not be readily available and must be security controlled.

## User Manual

### Electrical Connection

The installation of all ZCode - safety switches must be in accordance with a risk assessment for the individual application. For monitoring the ZCode switches, the two redundant outputs must be connected to a safety emergency stop relay (e.g. ZANDER SR"C") or a dual channel connection has to be made with the inputs of a safety PLC (e.g. ZANDER TALOS).

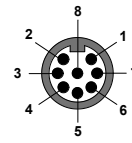

Figure 4: View of M12-Connector

M12	Colour	Signal
2	red	operating voltage, 24V
3	blue	operating voltage, GND
7	black	safety contact 1, NC
1	white	safety contact 1, NC
4	yellow	safety contact 2, NC
6	green	safety contact 2, NC
<b>Optional</b>		
8	orange	auxiliary contact AUX, NO
5	brown	auxiliary contact AUX, NO

Figure 5: Terminals M12 Connector

### Applications

When connecting one ZCode to a ZANDER emergency stop safety relay the highest Performance Level PL e, category 4 will be achieved.

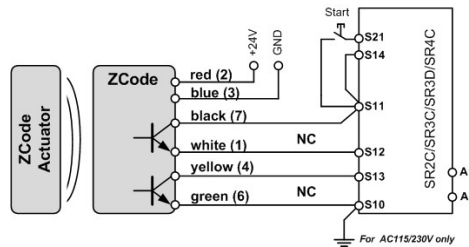

Figure 5: Single connection of a ZCode to one ZANDER SR"C" (category 4, PL e)

However, it is also possible to connect up to 3 ZCode safety sensors to one safety relay (e.g. ZANDER SR) up to PL d, safety category 3. For recognizing possible single faults each door should be opened and closed individually.

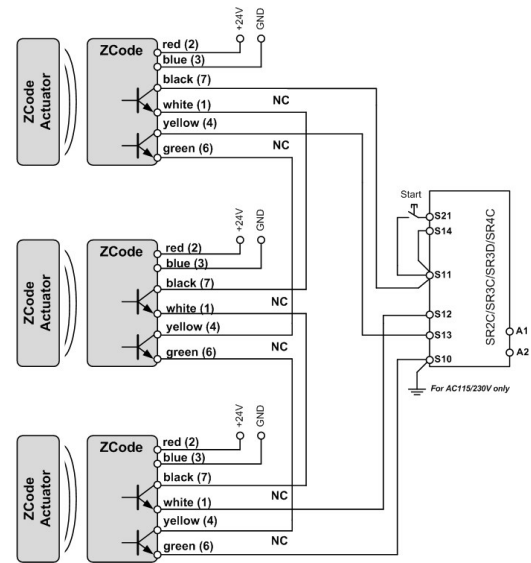

Figure 6: Connecting up to 3 ZCode in series to one ZANDER SR"C" (safety category 3, PL d)

### Commissioning Procedure

**Attention:** During commissioning the items under „Electrical Connection“ has to be considered. (see above)



#### 1. Mounting the device:

See subitem „Installation“. Check the correct distance between switch and actuator.

#### 2. Wiring:

Installation of all switches and safety relays must be in accordance to your application and the required Performance Level (see Fig. 5, Fig. 6).

**Caution:** Check the installation specifications of the used emergency stop safety relay.

Wiring only in de-energized state.

#### 3. Starting the device:

Switch on the operating voltage for the safety switch and safety emergency stop relay.

#### 4. Check your application:

After installation always check each switch function by opening and closing each guard individually in turn.

Ensure that the green LED at the switch and also both LED's on the safety inputs of the emergency stop safety relay are lit while the door is closed and are extinguished when the switch is open.

#### 5. Triggering safety function:

Check that the machine stops and cannot be re-started when a switch is open.

## User Manual

### Maintenance

**Monthly:** Check alignment of actuator. Check switch case and wiring for signs of mechanical damage.

For applications where infrequent guard access is foreseeable, the system must have a manual function test to detect a possible accumulation of faults. At least once per month for PL e Cat. 3/4 or once per year for PL d Cat. 3 (ISO 13849-1). Where possible it is recommended that the control system of the machine demands and monitors these tests, and stops or prevents the machine from starting if the test is not done (ISO 14119).

Check that the machine stops and cannot be re-started when each switch is open.

Check each switch function and each door individually in turn and ensure that the green light on the switch and appropriate LEDs on the safety relay are illuminated when the switch is closed and are extinguished when the switch is open. Check that the machine stops and cannot be re-started when each switch is open.

Never repair any switch, actuator or integral cables. Replace any switch displaying signs of mechanical damage to casing or cables.

The device is otherwise maintenance free, provided that it was installed properly.

### What to Do in Case of a Fault?

**Device does not switch on:**

- Check the wiring by comparing it to the wiring diagrams.
- Check the safety switch for correct adjustment.
- Check if the green LED is lit when the switch is closed.
- Check the operating voltage.

If the fault still exists, perform the steps listed under "Commissioning Procedure".

If these steps do not remedy the fault either, return the device to the manufacturer for examination.

**Opening the device is impermissible and will void the warranty.**

### Safety Characteristics According to DIN EN ISO 13849-1

The device is certified according to DIN EN ISO 13849-1 up to a Performance Level of PL e .

The specified PL (for applications according to Fig. 5) values were determined under the following worst-case conditions for a guard door monitoring.

**Note:**

Additional data can be requested from the manufacturer for applications that deviate from these conditions.

Safety Characteristics according to DIN EN ISO 13849-1 / EN 62061	
Performance Level	e (according to Fig. 5)
Categorie	4
MTTF <sub>d</sub>	High
Safety Integrity Level	SIL 3
PFHd (1/h)	2,6 x 10 <sup>-8</sup> (1/h)
Proof Test Intervall	20 years
Annual Usage	8 cycles per hour / 24 hours a day / 365 days
Load case	Full load 100 mA

### Techn. Data

Correspondents to the standards	ISO 13849-1; EN 62061, EN ISO 14119; EN 60204-EN 60947-5-3; UL508, CSA-C22.2 No.14
Approvals	CE, TÜV, UL
Power Supply	DC 24 V, +/- 15 %, max. 50 mA
Contact rating safety outputs	DC 24 V, max. 200 mA, short circuit proof
Contact rating auxiliary output	DC 24 V, max. 200 mA, short circuit proof
Contact release time	max. 2 ms
Switching reliability	3,3x10 <sup>6</sup> at 100 mA
Minimum switched current	10 V DC, 1 mA
Delectric withstand	AC 250 V
Insulation resistance	100 MOhm
Recommended setting gap	5 mm
Switching distance, max.	SaO 10 mm Close / SaR 20 mm Open
Tolerance to misalignment	5 mm in any direction from 5 mm setting gap
Switching frequency	max. 1,0 Hz
Approach speed	200 mm/min - 1000 mm/s
Body material	Red Plastic / Stainless Steel 316, mirror polished finish to Ra4
Dimensions	36 x 26 x 13 mm
Weight	approx. 200 g (Plastic) / approx. 300 g (Stainless Steel)
IP Protection	IP67 Plastic / IP69K Stainless Steel
Temperature Range	-25 °C to +80 °C Plastic, +105 °C Stainless Steel (CIP, SIP cleaning)
Shock Resistance	11 ms 30 g according to IEC 68-2-27
Vibration Resistance	10 - 55 Hz 1 mm according to IEC 68-2-6
Cable Type	PVC 6 core, 6 mm O.D. for 2 NC
Mounting	each 2 x M4 screws; 1 Nm recommended; any position

## User Manual

### Dimensions

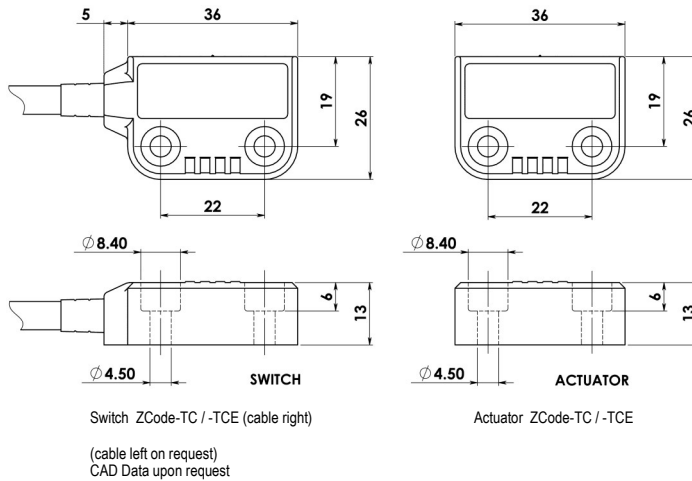

### Types

Order No. 940151	ZCode-TC, 5 m Cable, 2NC, Plastic, incl. Actuator
Order No. 940153	ZCode-TCE, M12-Connector, 2NC/1NO, Stainless Steel, incl. Actuator
Order No. 940154	ZCode-TC, 5 m Cable, 2NC/1NO, Plastic, incl. Actuator
Order No. 940155	ZCode-TC, M12-Connector, 2NC/1NO, Plastic, incl. Actuator
Order No. 940157	Spare Actuator Stainless Steel for ZCode-TCE
Order No. 940158	Spare Actuator Plastic for ZCode-TC
Order No. 941200	M12 Extension Cable, 15 m lengths, PUR, female M12x1, open end cable

## CE Konformitätserklärung EC Declaration of Conformity Déclaration de conformité

**Hersteller:** H. ZANDER GmbH & Co. KG  
**Producer:** Am Gut Wolf 15 • 52070 Aachen • Deutschland  
**Fabricant:**

**Produktgruppe:** Sicherheitsschaller  
**Product Group:** Safety Switch  
**Groupe de produits:** Interrupteur de sécurité

Produkt Name Product Name Nom du produit	Anbringung der CE-Kennzeichnung Affixing of CE marking: Application du marque CE	Zertifikats-Nr. No of Certificate N° du certificat
ZCode-LC/ZCode-LCE	2016	968/FSP 1284.00/16
ZCode-TG/ZCode-TCE	2016	968/FSP 1284.00/16
ZCode-PG/ZCode-MC	2016	968/FSP 1284.00/16
ZCode -CCE/ZCode-CCEF	2016	968/FSP 1284.00/16
ZCode-KG/ZCode-CC	2016	968/FSP 1284.00/16
ZCode-RG/ZCode-RCE	2016	968/FSP 1284.00/16
ZCode-MCF	2016	968/FSP 1284.00/16

**Die Produkte stimmen mit den Vorschriften folgender Europäischer Richtlinien überein:**  
The products conform with the essential protection requirements of the following European directives:  
Les produits sont conformes aux dispositions des directives européennes suivantes:

**2006/42/EG** : Maschinenrichtlinie  
2006/42/EG : Machinery directive  
2006/42/EG : Directive <<Machines>>

**2004/108/EG** : EMV Richtlinie bis 2016-04-19  
2004/108/EG : EMC directive till 2016-04-19  
2004/108/EG : Directive <<CEM>> jusqu' à 2016-04-19

**2014/30/EU** : EMV Richtlinie ab 2016-04-20  
2014/30/EU : EMC directive from 2016-04-20  
2014/30/EU : Directive <<CEM>> dès 2016-04-20

**Die Übereinstimmung der bezeichneten Produkte mit den Vorschriften der o.a. Richtlinie wird, falls anwendbar, nachgewiesen durch die vollständige Einhaltung folgender Normen:**  
If applicable, the conformity of the designated products is proved by full compliance with the following standards:  
Le strict respect des norms suivantes confirme, s'il y a lieu, que les produits désignés sont conformes aux dispositions de la directive susmentionnée:

EN 60204-1 2006:+A1:2009+AC:2010

**Gemäß Zertifikat TÜV-Rheinland:**  
According to the certificate of TÜV-Rheinland:  
Selon de organisme TÜV-Rheinland:

IEC 60947-5-3

ISO 14119:2013

ISO 13849-1:2006+TC1:2009

Dokumentationsbeauftragte/r: Christiane Nittschalk  
Documentation manager  
Autorisé à constituer le dossier technique

Aachen, den 08.11.2016

Dipl.-Ing. Walter Zander  
Geschäftsleitung  
General Manager  
Direction

Dipl.-Ing. Alfons Austerhoff  
Leiter CE-Konformitätsbewertung  
Manager for EC declaration of conformity  
Responsable évaluation de conformité CE

F7.3-0703

J08

E61-194-00