

---

# SimplIQ<sub>Line</sub>

---

## **Solo Guitar Digital Servo Drive Installation Guide**



**October 2017 (Ver. 1.404)**



[www.elmomc.com](http://www.elmomc.com)

## Notice

This guide is delivered subject to the following conditions and restrictions:

- This guide contains proprietary information belonging to Elmo Motion Control Ltd. Such information is supplied solely for the purpose of assisting users of the Solo Guitar servo drive in its installation.
- The text and graphics included in this manual are for the purpose of illustration and reference only. The specifications on which they are based are subject to change without notice.
- Elmo Motion Control and the Elmo Motion Control logo are trademarks of Elmo Motion Control Ltd.
- Information in this document is subject to change without notice.

Document no. MAN-SOLGUIIG (Ver. 1.404)

Copyright © 2017

Elmo Motion Control Ltd.

All rights reserved.

## Catalog Number



**Note:** There are two models of the Solo Guitar: connectors only (for currents of 30 A or less) and wires only (for currents of 35 A or more). On request, the wires model may be ordered for currents of 30 A or less.

## Revision History

Version	Date	Details
Ver. 1.0	August 2008	Initial Release
Ver. 1.1	November 2008	Correction to J6 & J7 pinout diagrams
Ver. 1.2	May 2009	MTCR 01-009-41: Clarifications regarding models with connectors and wires on Notice page (above) and page 17. Changes to table in Section 3.3.1. MTCR 01-009-52: Added Section 3.4.3: Motor (Brake, PTC).
Ver. 1.3	March 2010	MTCR 01-010-05: Notice page (above): The note was updated, also updated on page 17. MTCR 04-009-48: Table 2: Pin 2 renamed to PR.
Ver. 1.4	September 2012	Update to main board Formatted according to the new template. “Metronome” was replaced by the “Composer” software.
Ver. 1.401	January 2013	Updated the Powerful Digital Output Interface table.
Ver. 1.402	February 2013	Updated the Opto Digital Output Interface table. Added a caution and recommendation on the type of cleaning solution to use for the Elmo unit.
Ver. 1.403	July 2014	General format changes
Ver. 1.404	October 2017	Updated Warranty Information section 1.5 and updated the part number label in section 3.2

## **Elmo Worldwide**

### **Head Office**

#### **Elmo Motion Control Ltd.**

60 Amal St., P.O. Box 3078, Petach Tikva 4951360  
Israel

Tel: +972 (3) 929-2300 • Fax: +972 (3) 929-2322 • [info-il@elmomc.com](mailto:info-il@elmomc.com)

### **North America**

#### **Elmo Motion Control Inc.**

42 Technology Way, Nashua, NH 03060  
USA

Tel: +1 (603) 821-9979 • Fax: +1 (603) 821-9943 • [info-us@elmomc.com](mailto:info-us@elmomc.com)

### **Europe**

#### **Elmo Motion Control GmbH**

Steinkirchring 1, D-78056, Villingen-Schwenningen  
Germany

Tel: +49 (0) 7720-85 77 60 • Fax: +49 (0) 7720-85 77 70 • [info-de@elmomc.com](mailto:info-de@elmomc.com)

### **China**

#### **Elmo Motion Control Technology (Shanghai) Co. Ltd.**

Room 1414, Huawen Plaza, No. 999 Zhongshan West Road, Shanghai (200051)  
China

Tel: +86-21-32516651 • Fax: +86-21-32516652 • [info-asia@elmomc.com](mailto:info-asia@elmomc.com)

### **Asia Pacific**

#### **Elmo Motion Control APAC Ltd.**

B-601 Pangyo Innovalley, 621 Sampyeong-dong, Bundang-gu, Seongnam-si, Gyeonggi-do,  
South Korea (463-400)

Tel: +82-31-698-2010 • Fax: +82-31-801-8078 • [info-asia@elmomc.com](mailto:info-asia@elmomc.com)

## *Table of Contents*

<b>Chapter 1: Safety Information .....</b>	<b>8</b>
1.1. Warnings.....	9
1.2. Cautions.....	9
1.3. Directives and Standards.....	10
1.4. CE Marking Conformance.....	10
1.5. Warranty Information .....	10
<b>Chapter 2: Introduction .....</b>	<b>11</b>
2.1. Drive Description .....	11
2.2. Product Features .....	12
2.2.1. Current Control.....	12
2.2.2. Velocity Control .....	12
2.2.3. Position Control .....	12
2.2.4. Advanced Position Control .....	13
2.2.5. Communication Options.....	13
2.2.6. Feedback Options.....	13
2.2.7. Fault Protection .....	13
2.3. System Architecture .....	14
2.4. How to Use this Guide.....	14
<b>Chapter 3: Installation .....</b>	<b>16</b>
3.1. Site Requirements .....	16
3.2. Unpacking the Drive Components.....	16
3.3. Pinouts.....	18
3.3.1. Connector Types for the Solo Guitar .....	18
3.4. Main Power and Motor Power .....	19
3.4.1. Connecting Motor Power .....	20
3.4.2. Connecting Main Power .....	21
3.4.3. Motor (Brake, PTC) .....	22
3.5. Main Feedback for the Solo Guitar.....	23
3.6. Main Buffered Output Port .....	29
3.7. Auxiliary Feedback (Bi-Directional) .....	31
3.7.1. Main and Auxiliary Feedback Combinations .....	32
3.7.2. Solo Guitar Auxiliary Feedback – Differential Buffered Encoder Output (YA[4]=4).....	35
3.7.3. Auxiliary Feedback – Differential Encoder Input Option (YA[4]=2).....	37
3.7.4. Auxiliary Feedback – Differential Pulse-and-Direction Input Option (YA[4]=0) .....	40
3.8. I/Os .....	42
3.8.1. Digital Input .....	42
3.8.2. Digital Output .....	44

3.8.3.	Analog Input .....	46
3.9.	Communications.....	47
3.9.1.	RS-232 Communication .....	47
3.9.2.	CAN Communication .....	49
3.10.	Powering Up .....	51
3.11.	Initializing the System.....	51
3.12.	Heat Dissipation.....	51
3.12.1.	How to Use the Charts.....	53
<b>Chapter 4: Technical Specifications .....</b>		<b>54</b>
4.1.	Features .....	54
4.1.1.	Motion Control Modes .....	54
4.1.2.	Advanced Positioning Control Modes .....	54
4.1.3.	Advanced Filters and Gain Scheduling.....	54
4.1.4.	Fully Programmable.....	54
4.1.5.	Feedback Options .....	55
4.1.6.	Input/Output .....	55
4.1.7.	Built-In Protection .....	56
4.1.8.	Accessories .....	56
4.1.9.	Status Indication .....	56
4.1.10.	Automatic Procedures .....	56
4.2.	Solo Guitar Dimensions .....	57
4.3.	Power Ratings .....	58
4.3.1.	Auxiliary Supply .....	58
4.4.	Environmental Conditions .....	59
4.5.	Control Specifications.....	59
4.5.1.	Current Loop.....	59
4.5.2.	Velocity Loop .....	60
4.5.3.	Position Loop .....	61
4.6.	Feedbacks .....	61
4.6.1.	Feedback Supply Voltage.....	61
4.6.2.	Main Feedback Options.....	62
4.6.2.1.	Incremental Encoder Input .....	62
4.6.2.2.	Digital Halls .....	63
4.6.2.3.	Interpolated Analog (Sine/Cosine) Encoder .....	63
4.6.2.4.	Resolver .....	64
4.6.2.5.	Tachometer.....	64
4.6.2.6.	Potentiometer .....	65
4.6.3.	Main Encoder Buffered Output .....	65
4.6.4.	Auxiliary Feedback Port (output mode YA[4]= 4) .....	66
4.6.5.	Auxiliary Feedback Port (input mode YA[4]= 2, 0).....	67
4.7.	I/Os .....	68
4.7.1.	Digital Input Interfaces .....	68
4.7.2.	Powerful Digital Output Interface .....	69
4.7.3.	Opto Digital Output Interface.....	70



4.7.4.	Brake .....	71
4.7.5.	Analog Input .....	71
4.8.	Communications.....	71
4.9.	Pulse-Width Modulation (PWM).....	72
4.10.	Compliance with Standards.....	72

## ***Chapter 1: Safety Information***

In order to operate the Solo Guitar servo drive safely, it is imperative that you implement the safety procedures included in this installation guide. This information is provided to protect you and to keep your work area safe when operating the Solo Guitar and accompanying equipment.

**Please read this chapter carefully before you begin the installation process.**

Before you start, ensure that all system components are connected to earth ground. Electrical safety is provided through a low-resistance earth connection.

Only qualified personnel may install, adjust, maintain and repair the servo drive. A qualified person has the knowledge and authorization to perform tasks such as transporting, assembling, installing, commissioning and operating motors.

The Solo Guitar servo drive contains electrostatic-sensitive components that can be damaged if handled incorrectly. To prevent any electrostatic damage, avoid contact with highly insulating materials, such as plastic film and synthetic fabrics. Place the product on a conductive surface and ground yourself in order to discharge any possible static electricity build-up.

To avoid any potential hazards that may cause severe personal injury or damage to the product during operation, keep all covers and cabinet doors shut.

The following safety symbols are used in this manual:



**Warning:**

This information is needed to avoid a safety hazard, which might cause bodily injury.



**Caution:**

This information is necessary for preventing damage to the product or to other equipment.



## 1.1. Warnings

- To avoid electric arcing and hazards to personnel and electrical contacts, never connect/disconnect the servo drive while the power source is on.
- Power cables can carry a high voltage, even when the motor is not in motion. Disconnect the Solo Guitar from all voltage sources before it is opened for servicing.
- The Solo Guitar servo drive contains grounding conduits for electric current protection. Any disruption to these conduits may cause the instrument to become hot (live) and dangerous.
- After shutting off the power and removing the power source from your equipment, wait at least 1 minute before touching or disconnecting parts of the equipment that are normally loaded with electrical charges (such as capacitors or contacts). Measuring the electrical contact points with a meter, before touching the equipment, is recommended.



## 1.2. Cautions

- The Solo Guitar servo drive contains hot surfaces and electrically-charged components during operation.
- The maximum DC power supply connected to the instrument must comply with the parameters outlined in this guide.
- When connecting the Solo Guitar to an approved 12 to 195 VDC auxiliary power supply, connect it through a line that is separated from hazardous live voltages using reinforced or double insulation in accordance with approved safety standards.
- Before switching on the Solo Guitar, verify that all safety precautions have been observed and that the installation procedures in this manual have been followed.
- Do not clean any of the Solo Guitar drive's soldering with solvent cleaning fluids of pH greater than 7 (8 to 14). The solvent corrodes the plastic cover causing cracks and eventual damage to the drive's PCBs.

Elmo recommends using the cleaning fluid Vigon-EFM which is pH Neutral (7).

For further technical information on this recommended cleaning fluid, select the link:

[http://www.zestron.com/fileadmin/zestron.com-usa/daten/electronics/Product\\_TI1s/TI1-VIGON\\_EFM-US.pdf](http://www.zestron.com/fileadmin/zestron.com-usa/daten/electronics/Product_TI1s/TI1-VIGON_EFM-US.pdf)

### 1.3. Directives and Standards

The Solo Guitar conforms to the following industry safety standards:

Safety Standard	Item
Approved <b>IEC/EN 61800-5-1, Safety</b>	Adjustable speed electrical power drive systems
Recognized <b>UL 508C</b>	Power Conversion Equipment
In compliance with <b>UL 840</b>	Insulation Coordination Including Clearances and Creepage Distances for Electrical Equipment
In compliance with <b>UL 60950-1</b> (formerly <b>UL 1950</b> )	Safety of Information Technology Equipment Including Electrical Business Equipment
In compliance with <b>EN 60204-1</b>	Low Voltage Directive 73/23/EEC

The Solo Guitar servo drive has been developed, produced, tested and documented in accordance with the relevant standards. Elmo Motion Control is not responsible for any deviation from the configuration and installation described in this documentation. Furthermore, Elmo is not responsible for the performance of new measurements or ensuring that regulatory requirements are met.

### 1.4. CE Marking Conformance

The Solo Guitar servo drive is intended for incorporation in a machine or end product. The actual end product must comply with all safety aspects of the relevant requirements of the European Safety of Machinery Directive 98/37/EC as amended, and with those of the most recent versions of standards **EN 60204-1** and **EN 292-2** at the least.

According to Annex III of Article 13 of Council Directive 93/68/EEC, amending Council Directive 73/23/EEC concerning electrical equipment designed for use within certain voltage limits, the Solo Guitar meets the provisions outlined in Council Directive 73/23/EEC. The party responsible for ensuring that the equipment meets the limits required by EMC regulations is the manufacturer of the end product.

### 1.5. Warranty Information

The products covered in this manual are warranted to be free of defects in material and workmanship and conform to the specifications stated either within this document or in the product catalog description. All Elmo drives are warranted for a period of 12 months from the date of shipment. No other warranties, expressed or implied — and including a warranty of merchantability and fitness for a particular purpose — extend beyond this warranty.

## *Chapter 2: Introduction*

The Solo Guitar is an integrated solution designed to simply and efficiently connect Elmo's Guitar servo drive directly to the application. The solution consists of the Guitar together with a convenient connection interface which either eliminates or reduces development time and resources when designing an application's PCB board.

This installation guide describes the Solo Guitar servo drive and the steps for its wiring, installation and power-up. Following these guidelines ensures maximum functionality of the drive and the system to which it is connected.

### **2.1. Drive Description**

The Solo Guitar series of digital servo drives is designed to deliver "the highest density of power and intelligence". The Solo Guitar delivers up to **4.8 kW of continuous power** or **5.4 kW of peak power** in a 227.9 cc (13.9 in<sup>3</sup>) package (80 x 61 x 46.7 mm or 3.15" x 2.4" x 1.84").

The Solo Guitar is designed for OEMs. It operates from a DC power source in current, velocity, position and advanced position modes, in conjunction with a permanent-magnet synchronous brushless motor, DC brush motor, linear motor or voice coil. It is designed for use with any type of sinusoidal and trapezoidal commutation, with vector control. The Solo Guitar can operate as a stand-alone device or as part of a multi-axis system in a distributed configuration on a real-time network.

The Solo Guitar drive is easily set up and tuned, using Elmo's *Composer* software tools. This Windows-based application enables users to quickly and simply configure the servo drive for optimal use with their motor. The Solo Guitar, as part of the *SimplIQ* product line, is fully programmable with the Elmo *Composer* motion control language.

Power to the Solo Guitar is provided by a 12 to 195 VDC isolated DC power source (not included with the Solo Guitar). A "smart" control-supply algorithm enables the Solo Guitar to operate with only one power supply, with no need for an auxiliary power supply for the logic.

If backup functionality is required for storing control parameters in case of power-loss, an external 12 to 195 VDC isolated supply should be connected (via the +VL terminal on the Solo Guitar) providing maximum flexibility and backup functionality when needed.

**Note:** This backup power supply can operate from any voltage source within the 12 to 195 VDC range. This is much more flexible than a standard 24 VDC power supply requirement.

If backup power is not needed, two terminals (VP and VL) are shorted so that the main power supply will also power the control/logic supply. In this way, there is no need for a separate control/logic supply.

The Solo Guitar is a PCB mounted device, which enables efficient and economic implementation.

The Solo Guitar is available in two models:

- The Standard Solo Guitar is a basic servo drive, which operates in current, velocity and position modes including Follower and PT & PVT. It operates simultaneously via RS-232 and CAN DS 301, DS 305, DS 402 communications and features a third-generation programming environment.
- The Advanced Solo Guitar includes all the motion capabilities and communication options included in the Standard model, as well as advanced positioning capabilities: ECAM, Dual Loop and increased program size.

Both versions operate with RS-232 and CAN communication.

## **2.2. Product Features**

### **2.2.1. Current Control**

- Fully digital
- Sinusoidal commutation with vector control or trapezoidal commutation with encoder and/or digital Hall sensors
- 12-bit current loop resolution
- Automatic gain scheduling, to compensate for variations in the DC bus power supply

### **2.2.2. Velocity Control**

- Fully digital
- Programmable PI and FFW (feed forward) control filters
- Sample rate two times current loop sample time
- “On-the-fly” gain scheduling
- Automatic, manual and advanced manual tuning and determination of optimal gain and phase margins

### **2.2.3. Position Control**

- Programmable PIP control filter
- Programmable notch and low-pass filters
- Position follower mode for monitoring the motion of the slave axis relative to a master axis, via an auxiliary encoder input
- Pulse-and-direction inputs
- Sample time: four times that of the current loop
- Fast event capturing inputs
- PT and PVT motion modes
- Fast output compare (OC)

### **2.2.4. Advanced Position Control**

This relates to the Advanced model only.

- Position-based and time-based ECAM mode that supports a non-linear follower mode, in which the motor tracks the master motion using an ECAM table stored in flash memory
- Dual (position/velocity) loop

### **2.2.5. Communication Options**

Depending on the application, Solo Guitar users can select from two communication options:

- RS-232 serial communication
- CAN for fast communication in a multi-axis distributed environment

### **2.2.6. Feedback Options**

- Incremental Encoder – up to 20 Mega-Counts (5 Mega-Pulse) per second
- Digital Halls – up to 2 kHz
- Incremental Encoder with Digital Halls for commutation – up to 20 Mega-Counts per second for encoder
- Interpolated Analog (Sine/Cosine) Encoder – up to 250 kHz (analog signal)
  - Internal interpolation - up to x4096
  - Automatic correction of amplitude mismatch, phase mismatch, signals offset
  - Auxiliary emulated, unbuffered, single-ended, encoder output
- Resolver
  - Programmable 10 to 15 bit resolution
  - Up to 512 revolutions per second (RPS)
  - Auxiliary emulated, unbuffered, single-ended, encoder output
- Tachometer, Potentiometer
- Elmo drives provide supply voltage for all the feedback options

### **2.2.7. Fault Protection**

The Solo Guitar includes built-in protection against possible fault conditions, including:

- Software error handling
- Status reporting for a large number of possible fault conditions
- Protection against conditions such as excessive temperature, under/over voltage, loss of commutation signal, short circuits between the motor power outputs and between each output and power input/return
- Recovery from loss of commutation signals and from communication errors

## 2.3. System Architecture

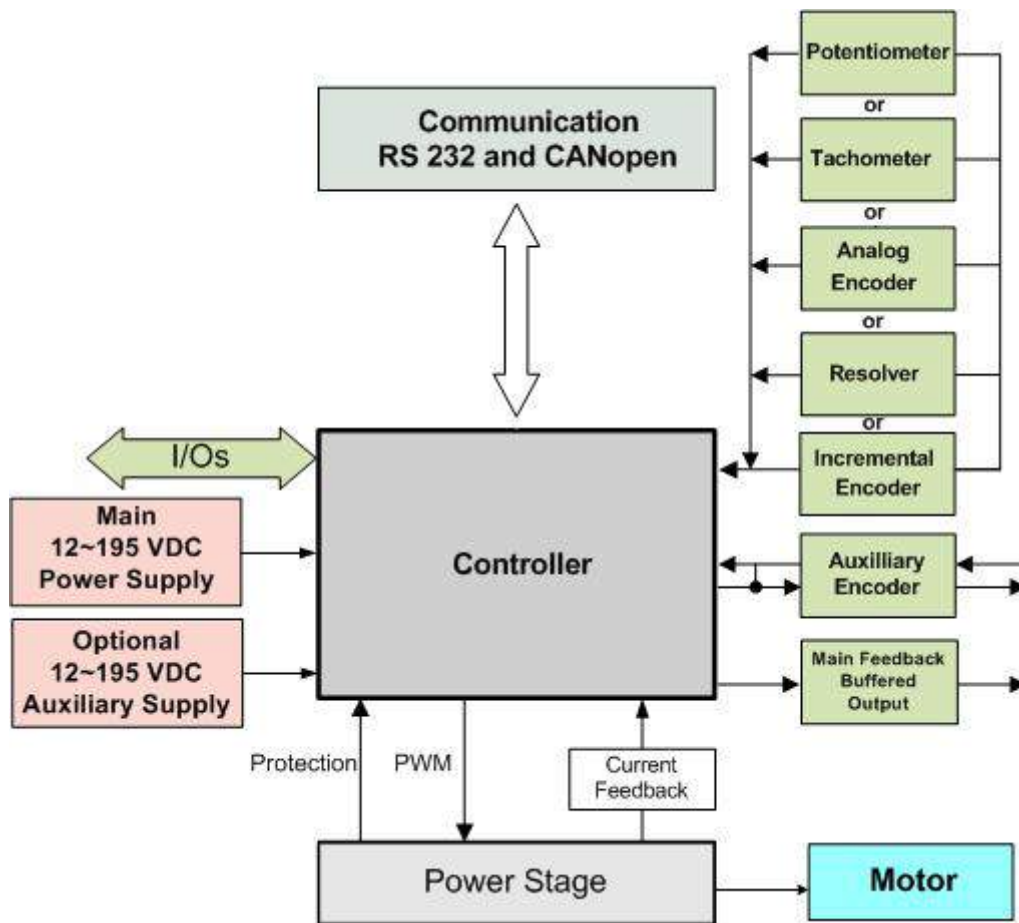


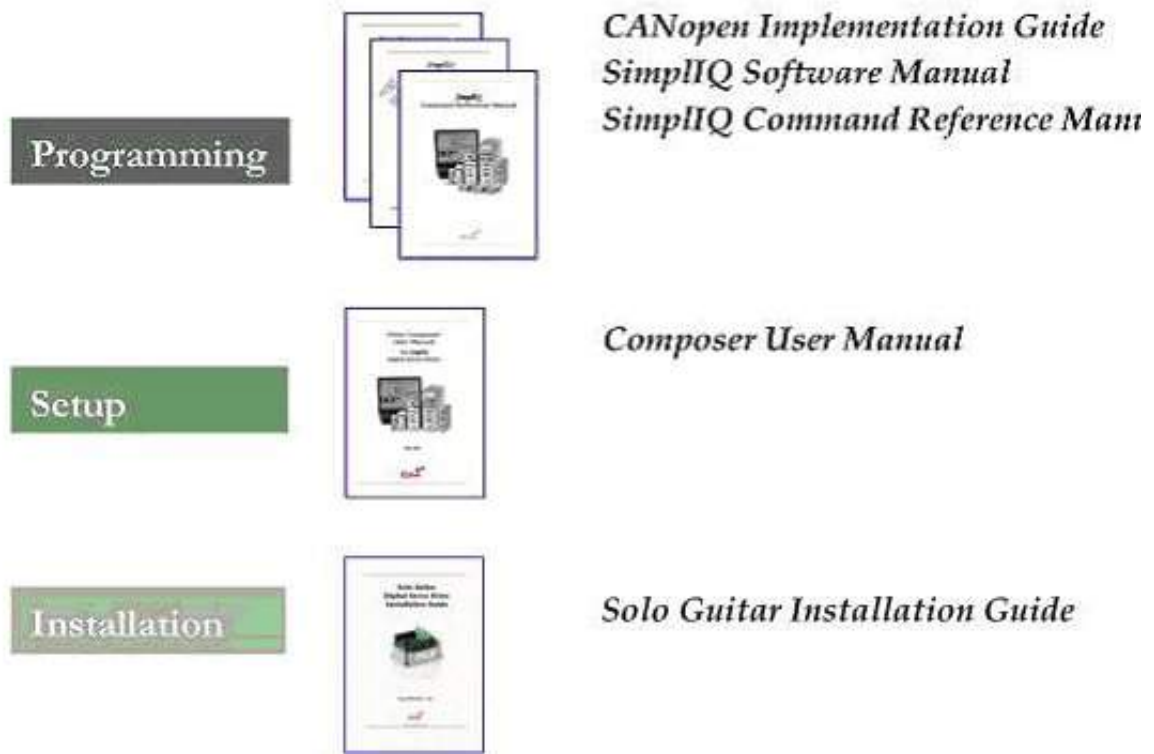
Figure 1: Solo Guitar System Block Diagram

## 2.4. How to Use this Guide

In order to install and operate your Elmo Solo Guitar servo drive, you will use this manual in conjunction with a set of Elmo documentation. Installation is your first step; after carefully reading the safety instructions in the first chapter, the following chapters provide you with installation instructions as follows:

- [Chapter 3, Installation](#), provides step-by-step instructions for unpacking, mounting, connecting and powering up the Solo Guitar
- [Chapter 4, Technical Specifications](#), lists all the drive ratings and specifications

Upon completing the instructions in this guide, your Solo Guitar servo drive should be successfully mounted and installed. From this stage, you need to consult higher-level Elmo documentation in order to set up and fine-tune the system for optimal operation. The following figure describes the accompanying documentation that you will require.



**Figure 2: Elmo Digital Servo Drive Documentation Hierarchy**

As depicted in the previous figure, this installation guide is an integral part of the Solo Guitar documentation set, comprising:

- The *SimplIQ Software Manual*, which describes the comprehensive software used with the Solo Guitar
- The *SimplIQ Command Reference Manual*, which describes, in detail, each software command used to manipulate the Solo Guitar motion controller
- The *Composer Software Manual*, which includes explanations of all the software tools that are part of Elmo's Composer software environment

## Chapter 3: Installation

The Solo Guitar must be installed in a suitable environment and properly connected to its voltage supplies and the motor.

### 3.1. Site Requirements

You can guarantee the safe operation of the Solo Guitar by ensuring that it is installed in an appropriate environment.

Feature	Value
Ambient operating temperature	0 °C to 40 °C (32 °F to 104 °F)
Maximum relative humidity	90% non-condensing
Operating area atmosphere	No flammable gases or vapors permitted in area
Models for extended environmental conditions are available.	



**Caution:** The Solo Guitar dissipates its heat by convection. The maximum operating ambient temperature of 0 °C to 40 °C (32 °F to 104 °F) must not be exceeded.

### 3.2. Unpacking the Drive Components

Before you begin working with the Solo Guitar, verify that you have all of its components, as follows:

- The Solo Guitar servo drive
- The Composer software and software manual

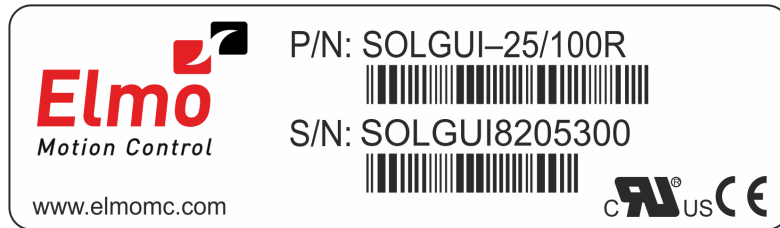
The Solo Guitar is shipped in a cardboard box with Styrofoam protection.

*To unpack the Solo Guitar*

1. Carefully remove the servo drive from the box and the Styrofoam.
2. Check the drive to ensure that there is no visible damage to the instrument. If any damage has occurred, report it immediately to the carrier that delivered your drive.
3. To ensure that the Solo Guitar you have unpacked is the appropriate type for your requirements, locate the part number sticker on the side of the Solo Guitar.

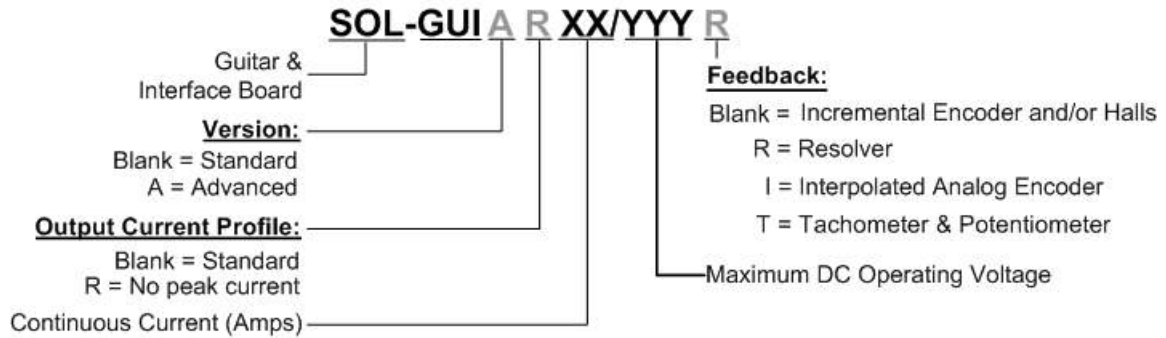


It looks like this:



SOLG004B

The part number at the top gives the type designation as follows:



- Verify that the Solo Guitar type is the one that you ordered, and ensure that the voltage meets your specific requirements.

**Note:** There are two models of the Solo Guitar: connectors only (for currents of 30 A or less) and wires only (for currents of 35 A or more). On request, the wires model may be ordered for currents of 30 A or less.

### 3.3. Pinouts

The Solo Guitar has seven connectors (in the connectors version).

#### 3.3.1. Connector Types for the Solo Guitar

No. Pins	Type	Port	Function
9	5.08 mm Pitch (Figure 3)		Power + Motor Power
2 (+seven wires)	5.08 mm Pitch (Figure 4) 14 AWG (M1, M2, M3, VP+, PR) 16 AWG (PE)	Wires	Power + Motor Power
4	2.54 mm Pitch	J4	Motor (Brake, PTC)
20	2.54 mm Pitch	J5	I/O
12	2.54 mm Pitch	J1	Communication
12	2.54 mm Pitch	J14	Main Feedback
8	2.54 mm Pitch	J17	Main Feedback Buffered Output
16	2.54 mm Pitch	J3	Auxiliary Feedback

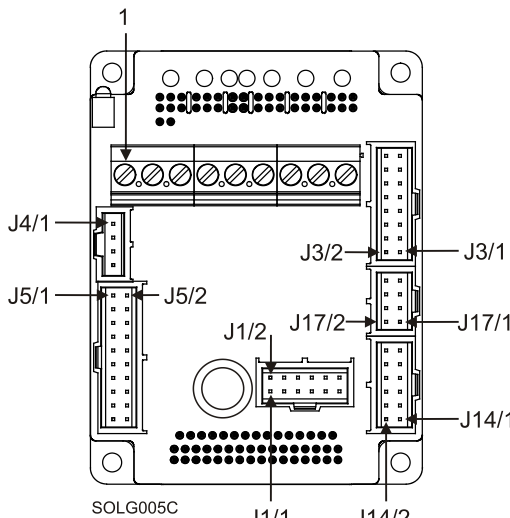
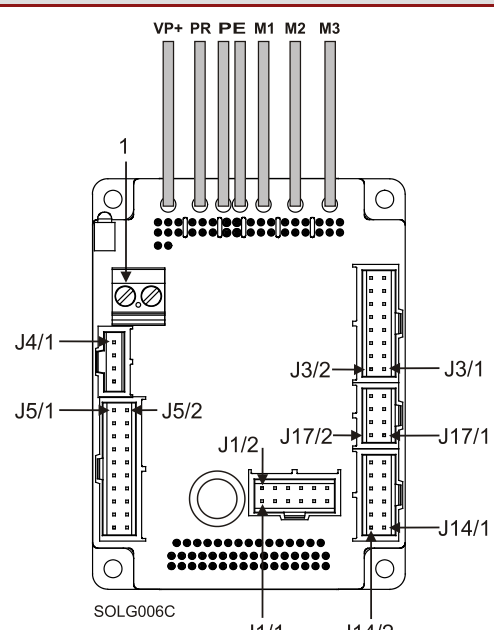
Connector Locations	
 <p>Figure 3</p>	 <p>Figure 4</p>

Table 1: Connector Types for the Solo Guitar

**Note:** Throughout this chapter there are pairs of diagrams of the Solo Guitar. The diagram on the left is the Solo Guitar with connectors and the diagram on the right shows the product with wires.

### 3.4. Main Power and Motor Power

The Solo Guitar receives power from main and auxiliary supplies and delivers power to the motor.

Pin	Signal	Function		
1	VL+	Auxiliary supply input		
2	PR	Auxiliary supply input return		
3	VP+	Pos. power input		
4	PR	Power return		
5	PE	Protective earth		
			AC Motor	DC Motor
6	PE	Protective earth	Motor	Motor
7	M1	Motor phase	Motor	N/C
8	M2	Motor phase	Motor	Motor
9	M3	Motor phase	Motor	Motor

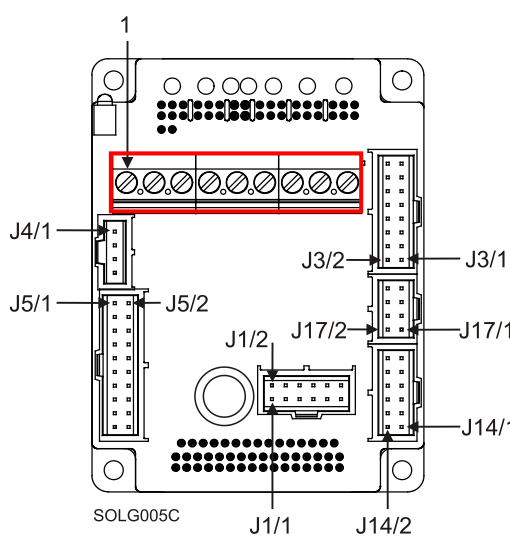
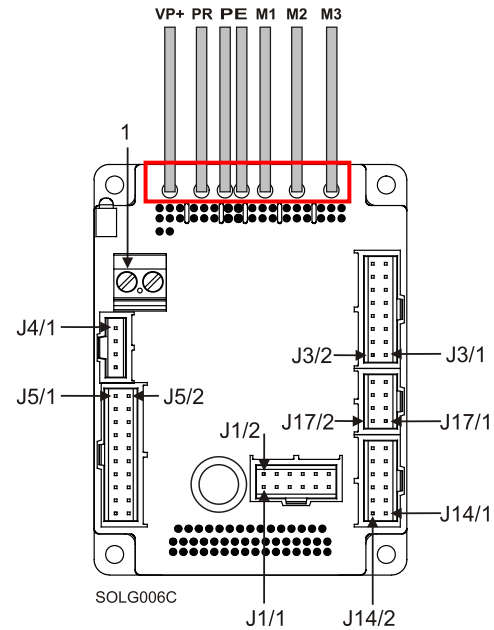
Pin Positions	
 <p>SOLG005C</p>	 <p>SOLG006C</p>

Table 2: Connector for Main Power and Motor Power

**Note:** When connecting several drives to several motors, all should be wired in the same motor phases and feedback sequences. This will enable the same *SimpliQ* program to run on all drives.

### 3.4.1. Connecting Motor Power

Connect the M1, M2, M3 and PE pins on the Solo Guitar. The phase connection is arbitrary as the Composer will establish the proper commutation automatically during setup. However, if you plan to copy the setup to other drives, then the phase order on all copy drives must be the same.

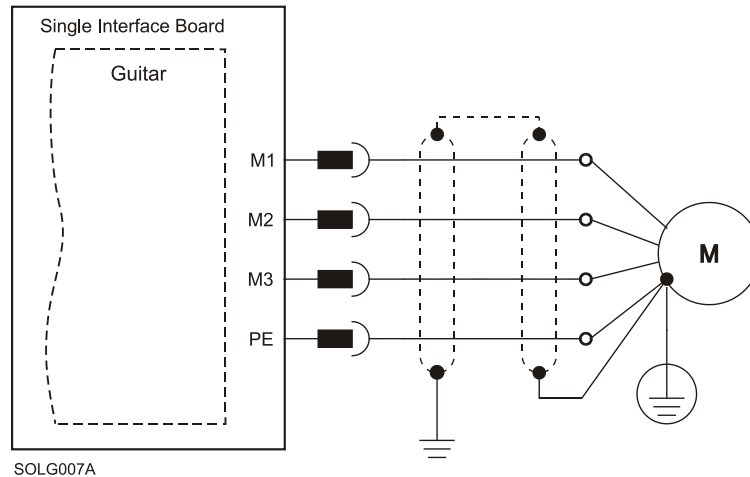


Figure 5: AC Motor Power Connection Diagram

### 3.4.2. Connecting Main Power

Power to the Solo Guitar is provided by a 12 to 195 VDC source. A smart control-supply algorithm enables the Solo Guitar to operate with the power supply only, with no need for an auxiliary 24 Volt supply. If backup functionality is required (for storing control parameters in case of power-outs) an additional backup supply can be connected by implementing "diode coupling" to the VL+.

**Note:** The source of the 12 to 195 VDC Main Power Supply must be isolated.

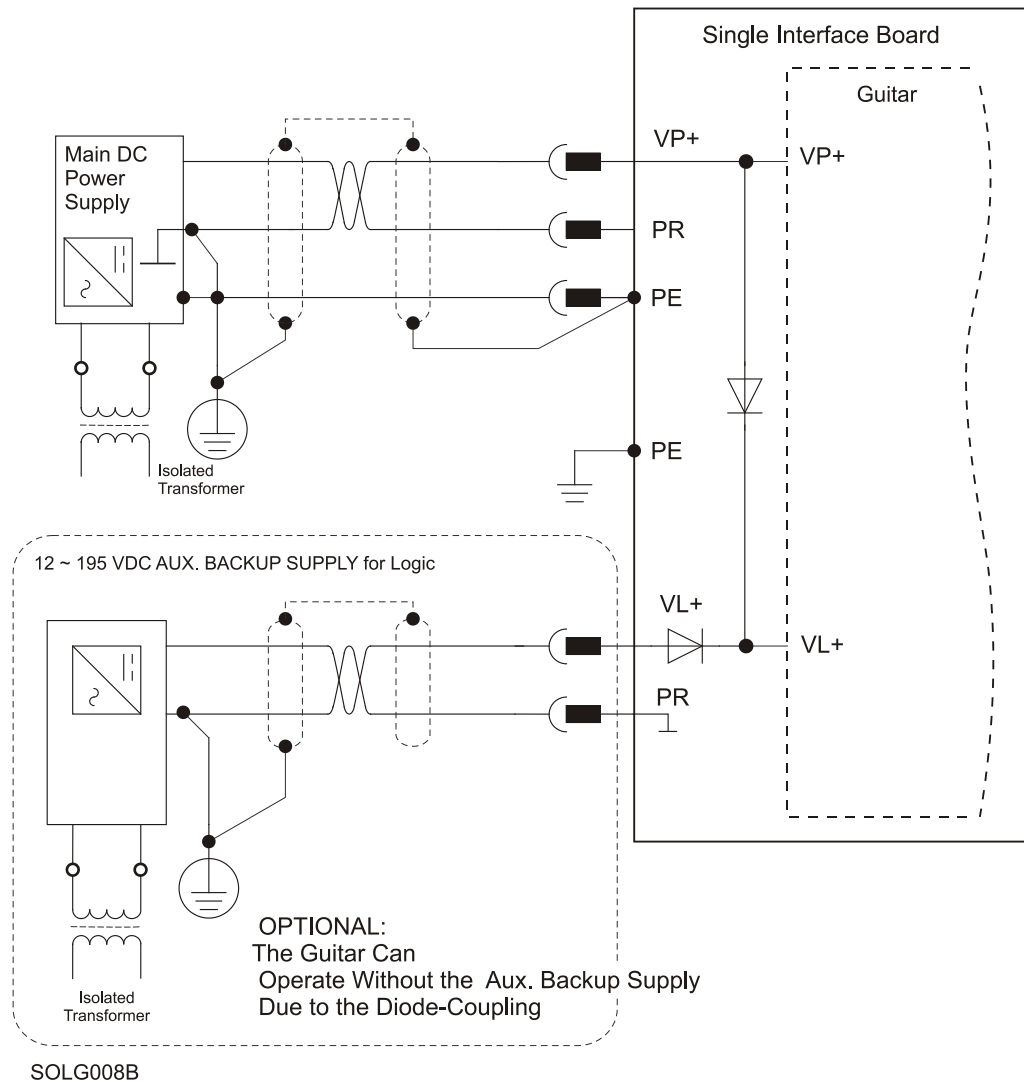


Figure 6: Shared Supply Connection Diagram

### 3.4.3. Motor (Brake, PTC)

Pin	Signal	Function
J4/1	BRAKE -	Brake (-) (coming from the motor)
J4/2	BRAKE +	Brake (+) (coming from the motor)
J4/3	PTC	Motor Protection Sensor (coming from the motor)
J4/4	PTC	Motor Protection Sensor (coming from the motor)

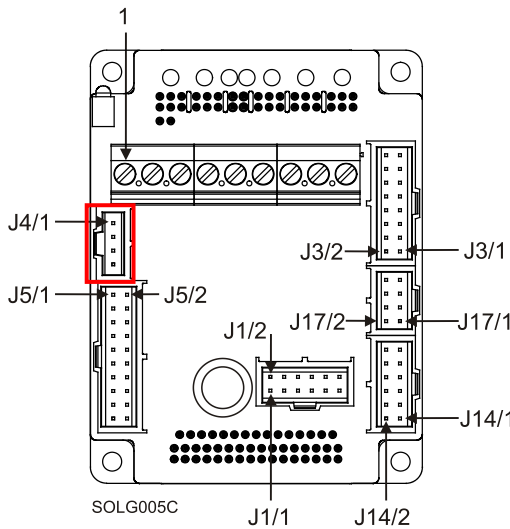
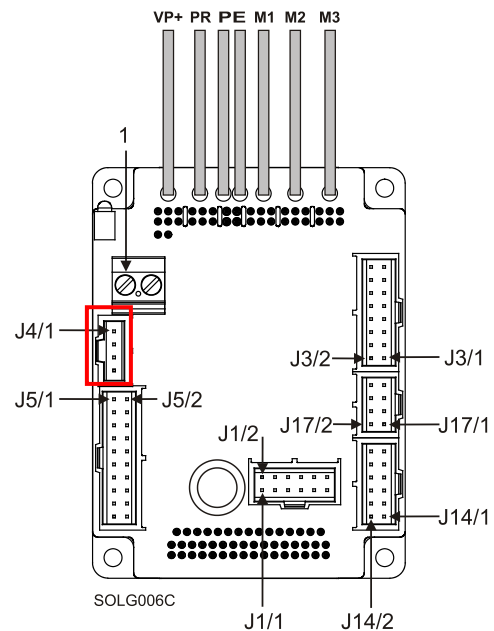
Pin Positions	
 <p>SOLG005C</p>	 <p>SOLG006C</p>

Table 3: The Motor Brake and PTC Connector

### 3.5. Main Feedback for the Solo Guitar

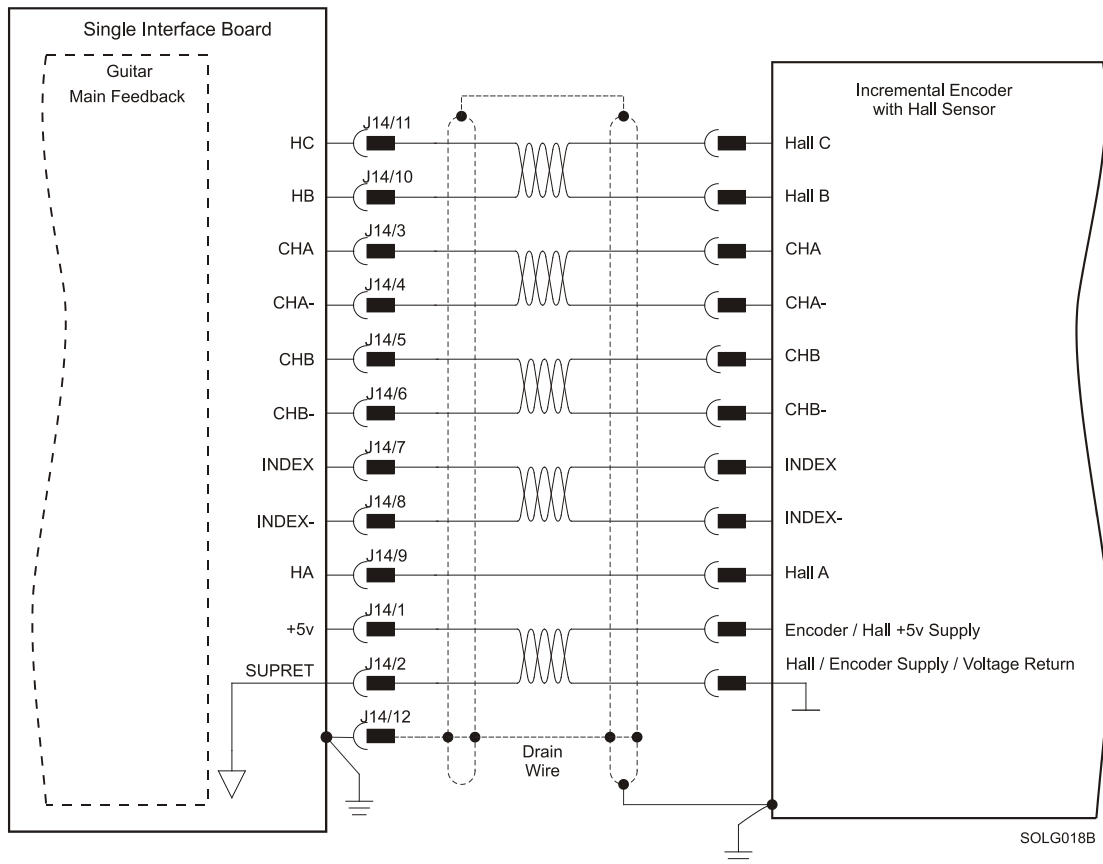
The Main Feedback port is used to transfer feedback data from the motor to the drive.

The Solo Guitar can accept any one of the following devices as a main feedback mechanism:

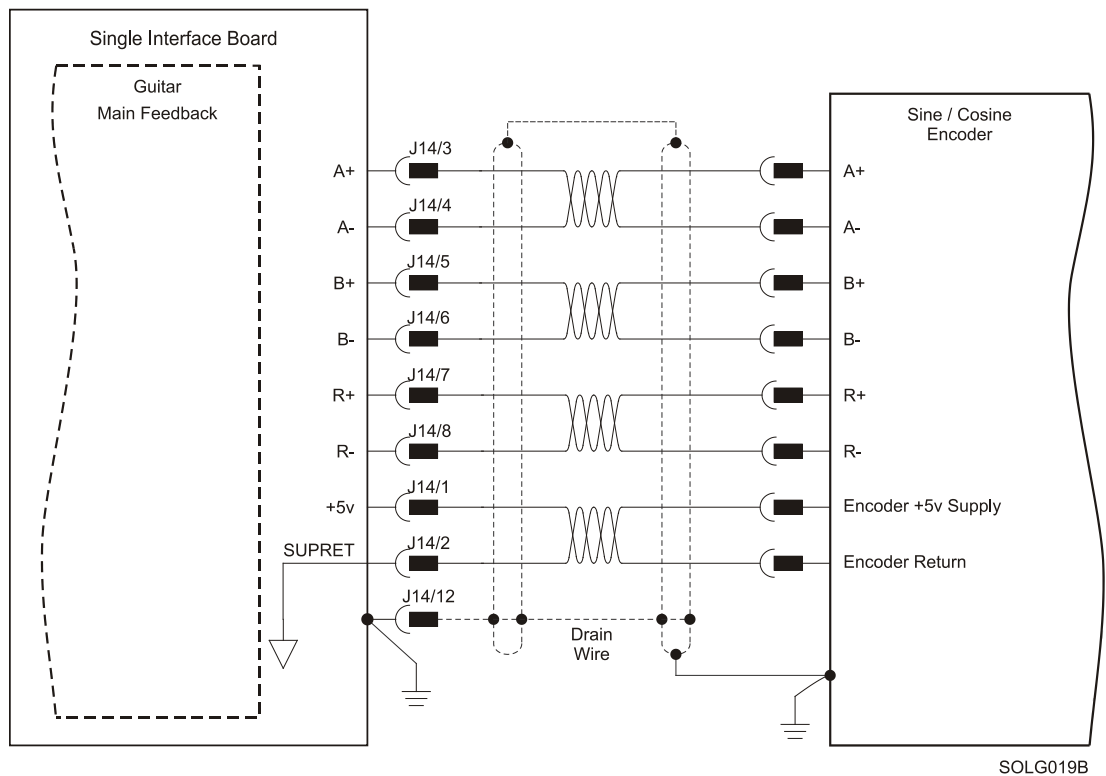
- Incremental encoder only
- Incremental encoder with digital Hall sensors
- Digital Hall sensors only
- Interpolated Analog (Sine/Cosine) encoder (option)
- Resolver (option)
- Tachometer (option)
- Potentiometer (option)

Pin (J14)	Incremental Encoder		Interpolated Analog Encoder		Resolver		Tachometer and Potentiometer	
	SOL-GUIXX/YYY_	SOL-GUIXX/YYYI	SOL-GUIXX/YYYI	SOL-GUIXX/YYYI	SOL-GUIXX/YYYR	SOL-GUIXX/YYYR	SOL-GUIXX/YYYT	SOL-GUIXX/YYYT
	Signal	Function	Signal	Function	Signal	Function	Signal	Function
11	HC	Hall sensor C input	HC	Hall sensor C input	NC	-	HC	Hall sensor C input
9	HA	Hall sensor A input	HA	Hall sensor A input	NC	-	HA	Hall sensor A input
12	PE	Protective Earth	PE	Protective Earth	PE	Protective Earth	PE	Protective Earth
2	SUPRET	Supply return	SUPRET	Supply return	SUPRET	Supply return	SUPRET	Supply return
1	+5V	Encoder/Hall +5V supply	+5V	Encoder/Hall +5V supply	+5V	Encoder/Hall +5V supply	+5V	Encoder/Hall +5V supply
4	CHA-	Channel A complement	A-	Sine A complement	S3	Sine A complement	Tac 1-	Tacho Input 1 Neg. (20 V max)
3	CHA	Channel A	A+	Sine A	S1	Sine A	Tac 1+	Tacho Input 1 Pos. (20 V max)
8	INDEX-	Index complement	R-	Reference complement	R2	Vref complmnt f= 1/TS, 50 mA Maximum	NC	-
7	INDEX	Index	R+	Reference	R1	Vref f=1/TS, 50 mA Max.	POT	Potentiometer Input (5 V Max)
10	HB	Hall sensor B input	HB	Hall sensor B input	NC	-	HB	Hall sensor B input
6	CHB-	Channel B complement	B-	Cosine B complement	S4	Cosine B complement	Tac 2-	Tacho Input 2 Neg. (50 V max)
5	CHB	Channel B	B+	Cosine B	S2	Cosine B	Tac 2+	Tacho Input 2 Pos. (50 V max)

Table 4: Solo Guitar Main Feedback Pin Assignments



**Figure 7: Main Feedback- Incremental Encoder with Digital Hall Sensors Connection Diagram**



**Figure 8: Main Feedback – Interpolated Analog (Sine/Cosine) Encoder Connection Diagram**



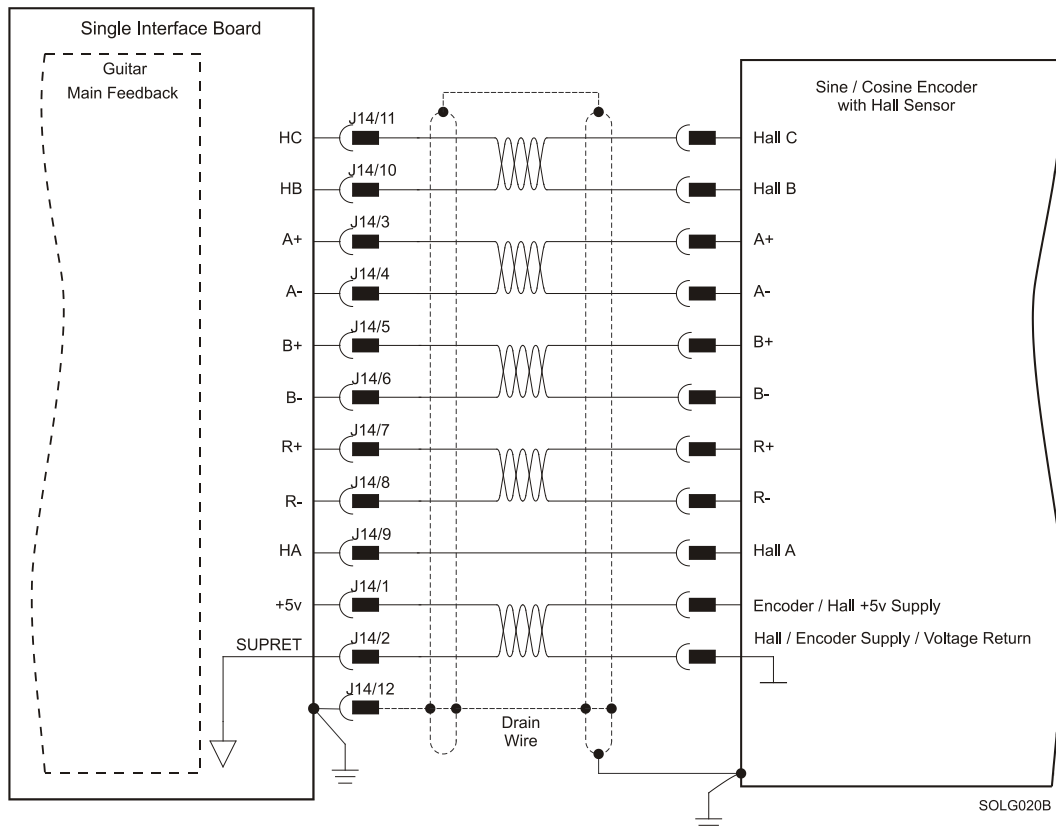


Figure 9: Main Feedback – Interpolated Analog (Sine/Cosine) Encoder with Digital Hall Sensors Connection Diagram

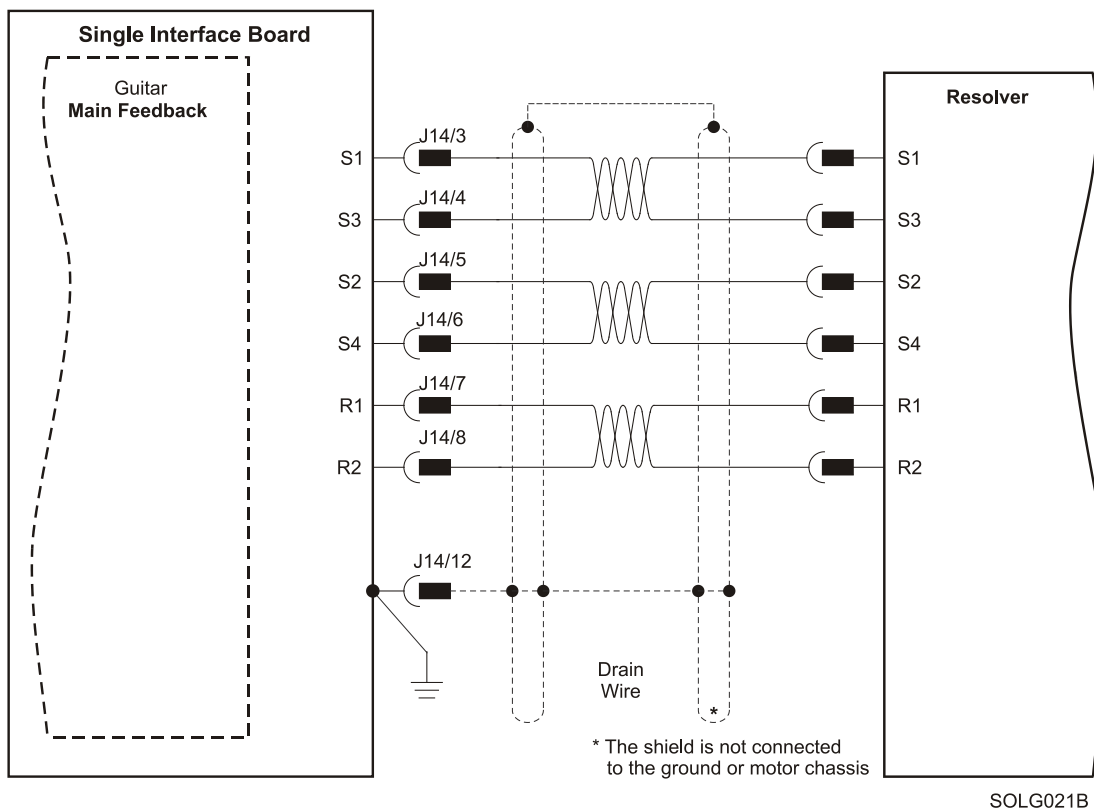
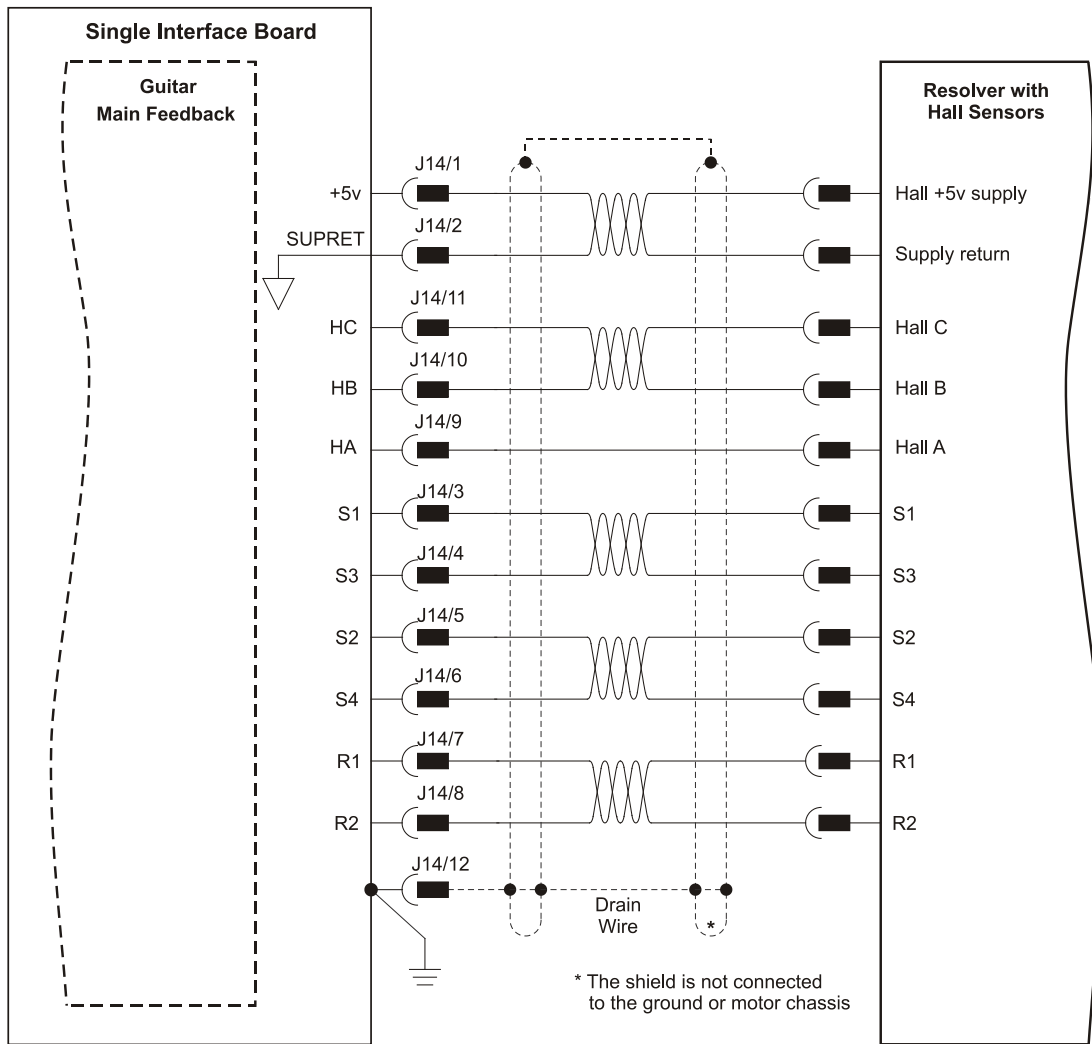
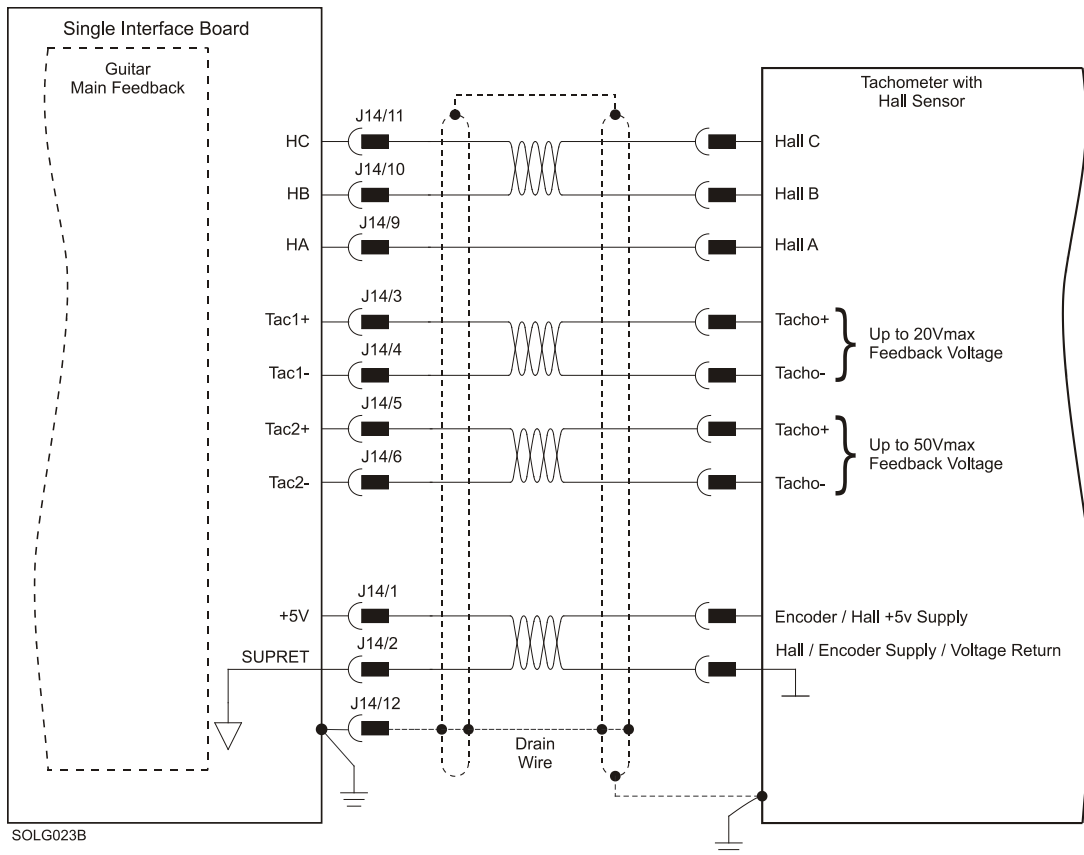


Figure 10: Main Feedback – Resolver Connection Diagram



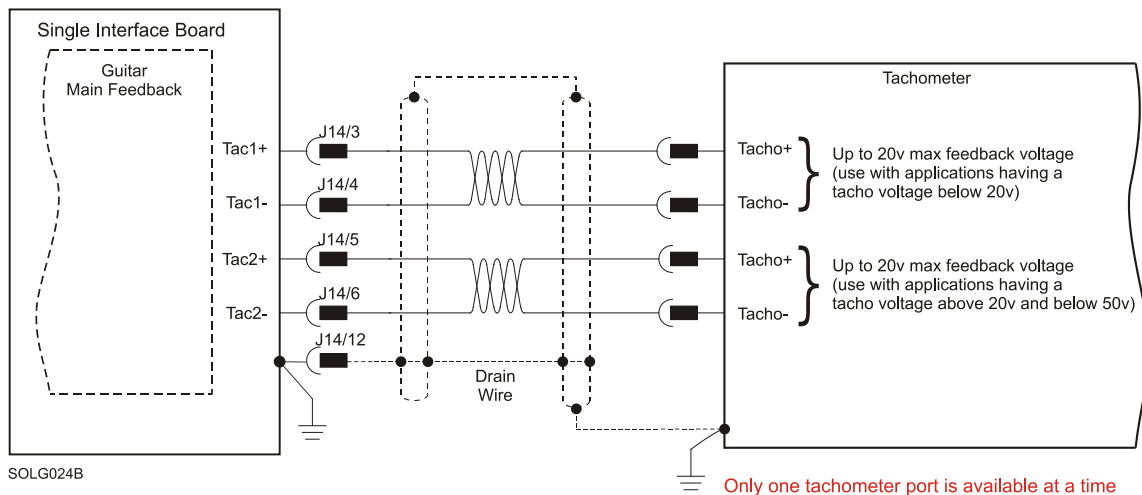
SOLG022B

Figure 11: Main Feedback – Resolver and Digital Hall Sensors Connection Diagram



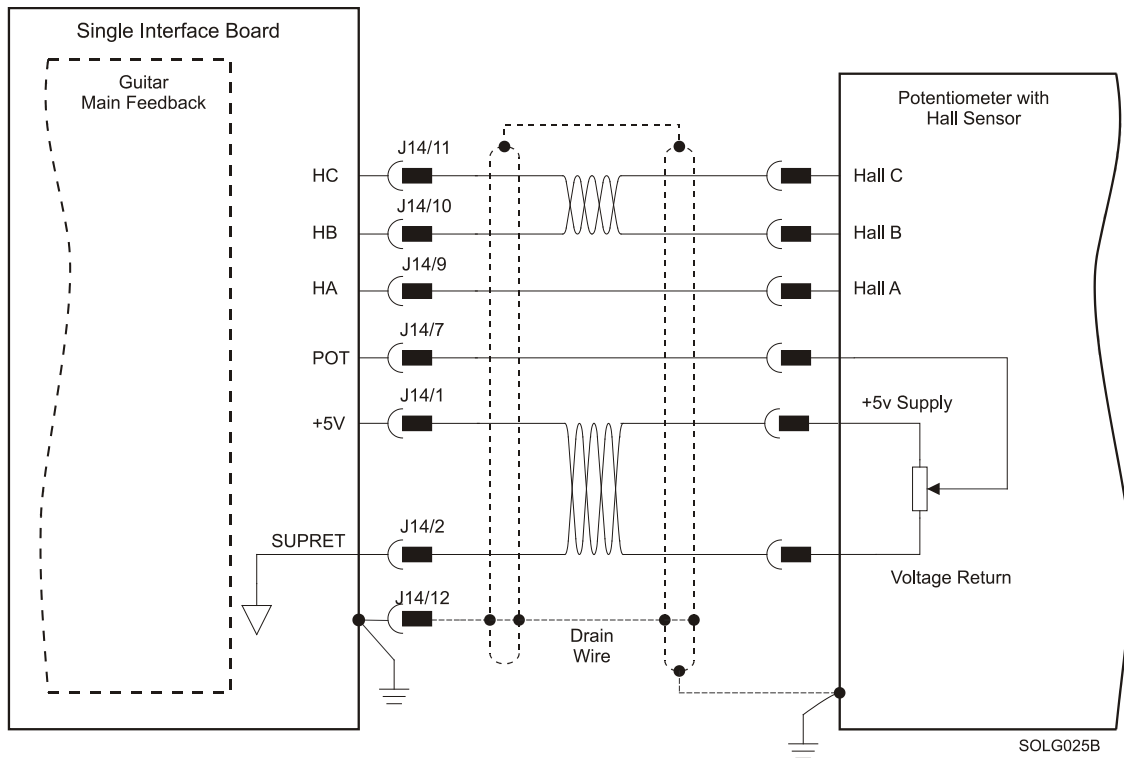
Only one tachometer port is available at a time

**Figure 12: Main Feedback – Tachometer Feedback with Digital Hall Sensors  
Connection Diagram for Brushless Motors**

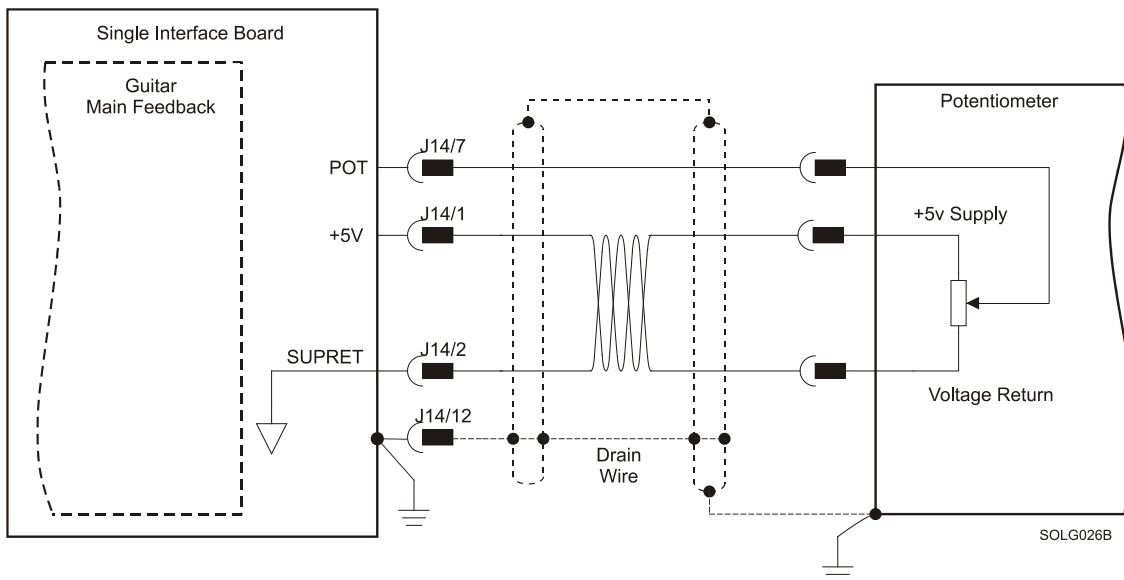


Only one tachometer port is available at a time

**Figure 13: Main Feedback – Tachometer Feedback Connection Diagram for Brush Motors**



**Figure 14: Main Feedback – Potentiometer Feedback with Digital Hall Sensors  
Connection Diagram for Brushless Motors**



**Figure 15: Main Feedback –  
Potentiometer Feedback Connection Diagram for Brush Motors and Voice Coils**

### 3.6. Main Buffered Output Port

This port provides Differential Buffered Outputs (of the Main Feedback) for another axis.

Pin (J17)	Signal	Function
1	CHAO	Buffered Channel A output
2	CHAO-	Buffered Channel A complement output
3	CHBO	Buffered Channel B output
4	CHBO-	Buffered Channel B complement output
5	INDEXO	Buffered Index output
6	INDEXO-	Buffered Index complement output
7	COMRET	Common return
8	PE	Protective Earth

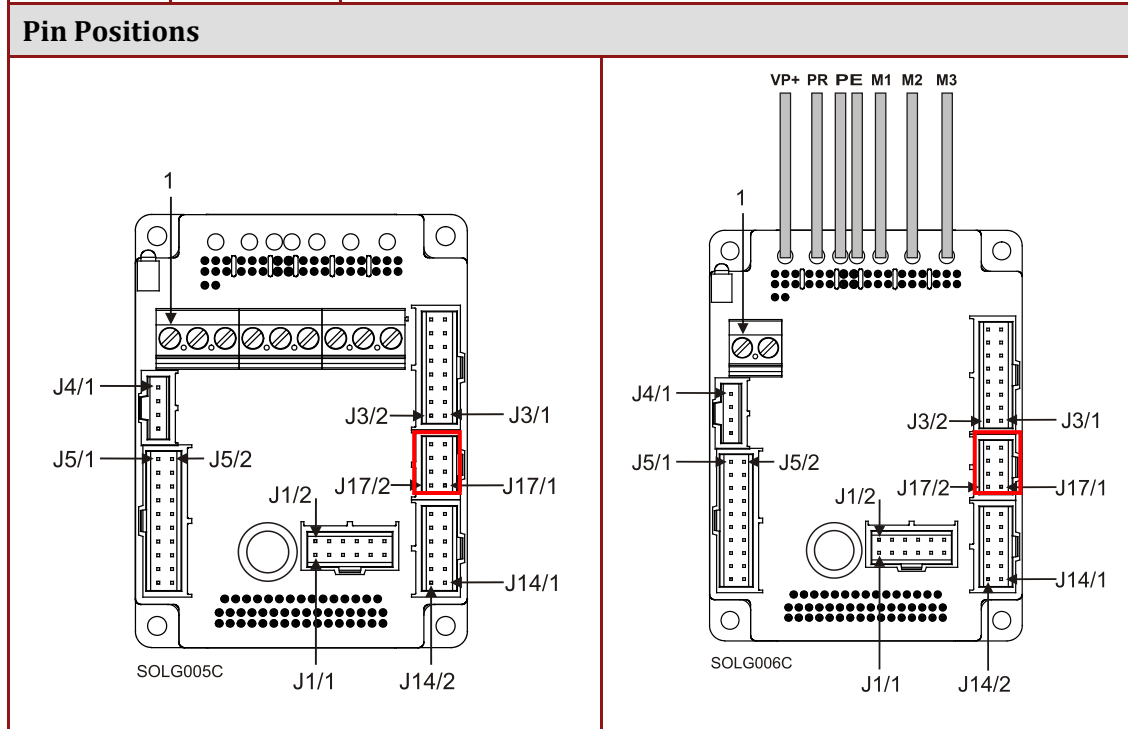
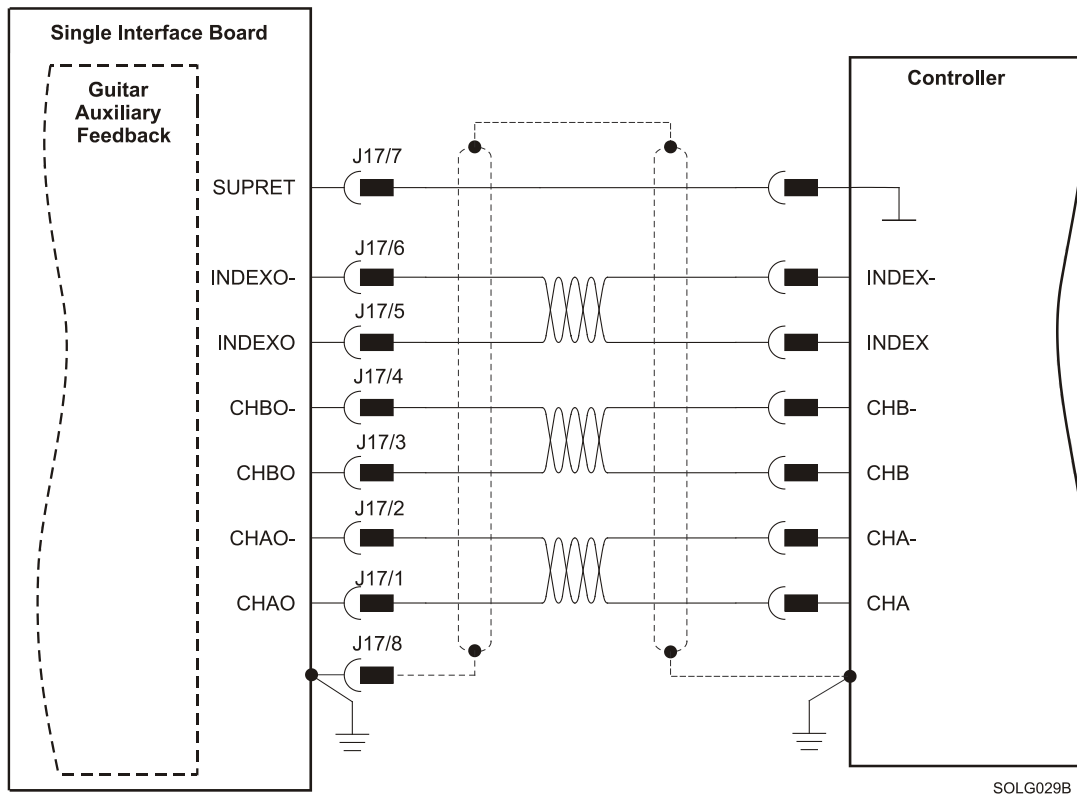


Table 5: Main Buffered Output Port - Pin Assignments



**Figure 16: Main Buffered Output Port (Differential Main Feedback Output) – Connection Diagram**

### 3.7. Auxiliary Feedback (Bi-Directional)

When using one of the Auxiliary Feedback options, the relevant functionality of the Auxiliary Feedback's ports are software selected for that option. Refer to the *SimplIQ Command Reference Manual* for detailed information about Auxiliary Feedback setup.

The Auxiliary Feedback connector has two ports: B1 and B2.

- **Port B1** has three pairs of differential buffered inputs
- **Port B2** has three pairs of differential buffered outputs

There are two modes of operation for this interface:

- Mode 1 (Composer Command: YA[4]=4) – see Section 3.7.2.

When the Auxiliary port of the Solo Guitar is set by the software to act as an emulated encoder output (this is practical only when using Resolver, Analog Encoder or Potentiometer and Tachometer as the Main Feedback):

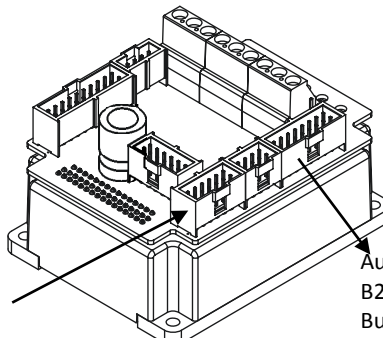
- B1 input becomes inactive.
  - B2 presents emulated differential buffered encoder output signals of the Main Feedback.
- Mode 2 (Composer Command: YA[4]=2 or YA[4]=0) – see Sections 3.7.3 and 3.7.4.

When the Auxiliary port of the Solo Guitar is set by software to act as an input

- B1 becomes an active differential buffered input.
- B2 presents differential buffered encoder output signals of B1.

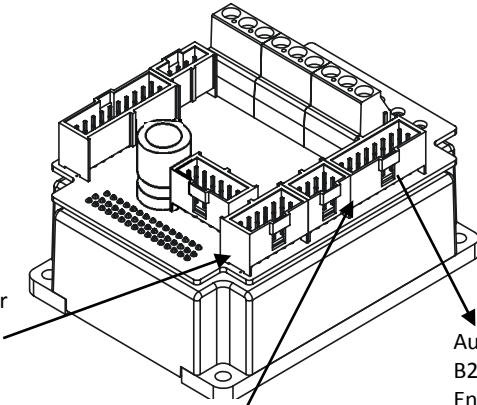
### 3.7.1. Main and Auxiliary Feedback Combinations

The Main Feedback is always used in motion control devices whereas Auxiliary Feedback is often, but not always used. The Auxiliary Feedback connector has two ports (B1 and B2). When used in combination with Main Feedback, the Auxiliary Feedback can be set by the software as follows:

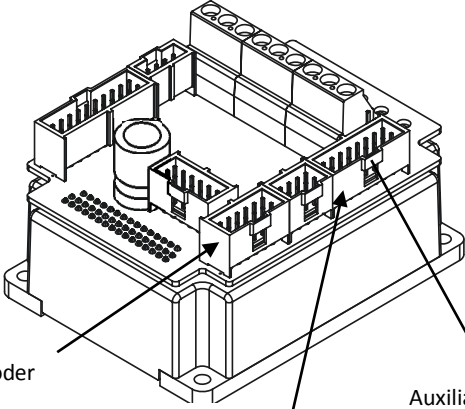
Auxiliary Feedback: Output	
<i>SW Setting</i>	<b>YA[4] = 4</b> (Auxiliary Feedback: output)
<b>Main Feedback</b>	<b>Auxiliary Feedback: NA</b>
<b>Incremental Encoder Input</b>	<b>Auxiliary Feedback: NA</b>
<b>Interpolated Analog (Sine/Cosine) Encoder Input*</b>	 <p style="text-align: left; margin-left: 10%;">Main Feedback: Interpolated Analog (Sin/Cos) Encoder OR Resolver OR Potentiometer OR Tachometer</p> <p style="text-align: right; margin-right: 10%;">Auxiliary Feedback: B2: Emulated Differential Buffered Encoder Output B1: NA</p>
<b>Resolver Input*</b>	
<b>Potentiometer Tachometer Input*</b>	
<b>Typical Applications</b>	<ul style="list-style-type: none"> <li>* Analog Encoder applications where position data is required, in the Encoder's quadrature format, for other purposes such as position controllers and/or other drives.</li> <li>* Resolver applications where position data is required in the Encoder's quadrature format, for other purposes such as position controllers and/or other drives.</li> <li>* Potentiometer and Tachometer applications where position data is required, in the Encoder's quadrature format, for other purposes such as position controllers and/or other drives</li> </ul>





<b>Auxiliary Feedback: Input</b>	
<b>SW Setting</b>	<b>YA[4] = 2</b> (Auxiliary Feedback: input)
<b>Main Feedback</b>	
<b>Incremental Encoder Input</b>	
<b>Interpolated Analog (Sine/Cosine) Encoder Input</b>	
<b>Resolver Input</b>	
<b>Potentiometer Tachometer Input</b>	
<b>Typical Applications</b>	<p>Any application where two Feedbacks are used by the drive.</p> <p>The Auxiliary Feedback port serves as an input for the Auxiliary incremental encoder.</p> <p>For applications such as Follower, ECAM, or Dual Loop.</p>



<b>Auxiliary Feedback: Input</b>	
<b>SW Setting</b>	<b>YA[4] = 0</b> (Auxiliary Feedback: input)
<b>Main Feedback</b>	
<b>Incremental Encoder Input</b>	
<b>Interpolated Analog (Sine/Cosine) Encoder Input</b>	
<b>Resolver Input</b>	
<b>Potentiometer Tachometer Input</b>	
	<p>Main Feedback: Incremental Encoder OR Interpolated Analog (Sin/Cos) Encoder OR Resolver OR Potentiometer OR Tachometer</p> <p>Auxiliary Feedback: B1: Differential Pulse &amp; Direction Commands Input</p> <p>Auxiliary Feedback: B2: Differential Buffered Pulse &amp; Direction Commands Output of B1</p>
<b>Typical Applications</b>	<p>Any application where two Feedbacks are used by the drive.</p> <p>The Auxiliary Feedback port serves as an input for Pulse &amp; Direction Commands.</p>

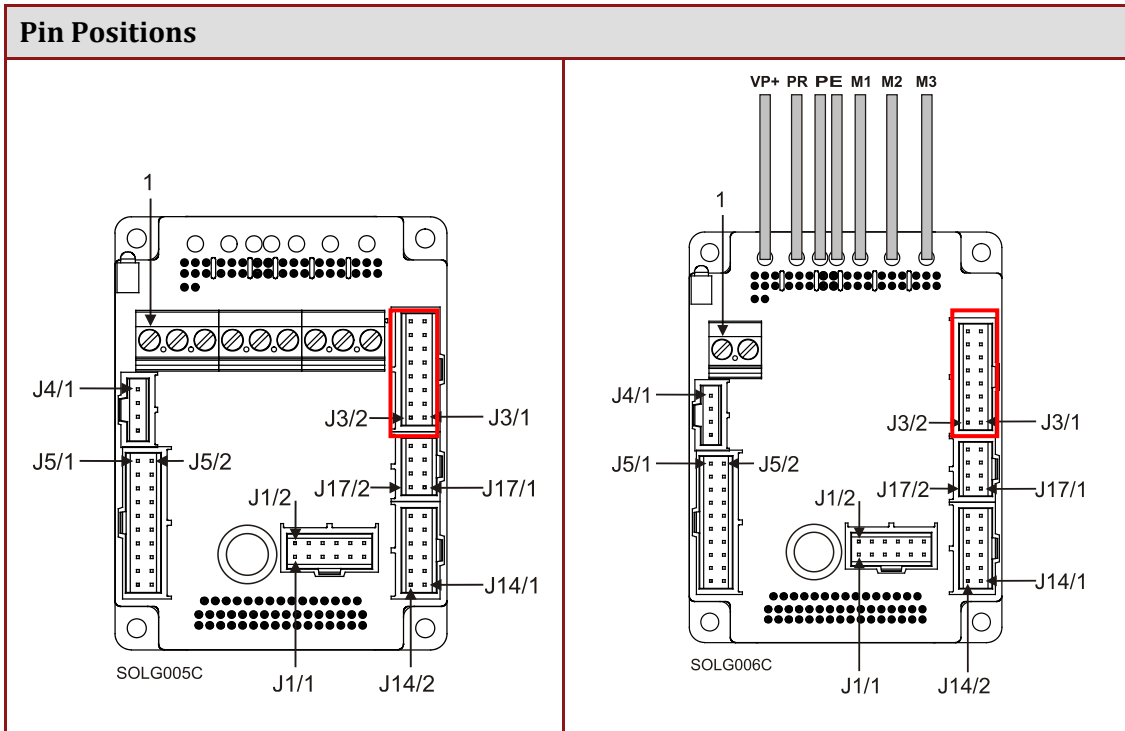
### 3.7.2. Solo Guitar Auxiliary Feedback – Differential Buffered Encoder Output (YA[4]=4)

The Auxiliary Feedback's B2 port can provide **emulated encoder signals** to other controllers or drives. This option can be used when:

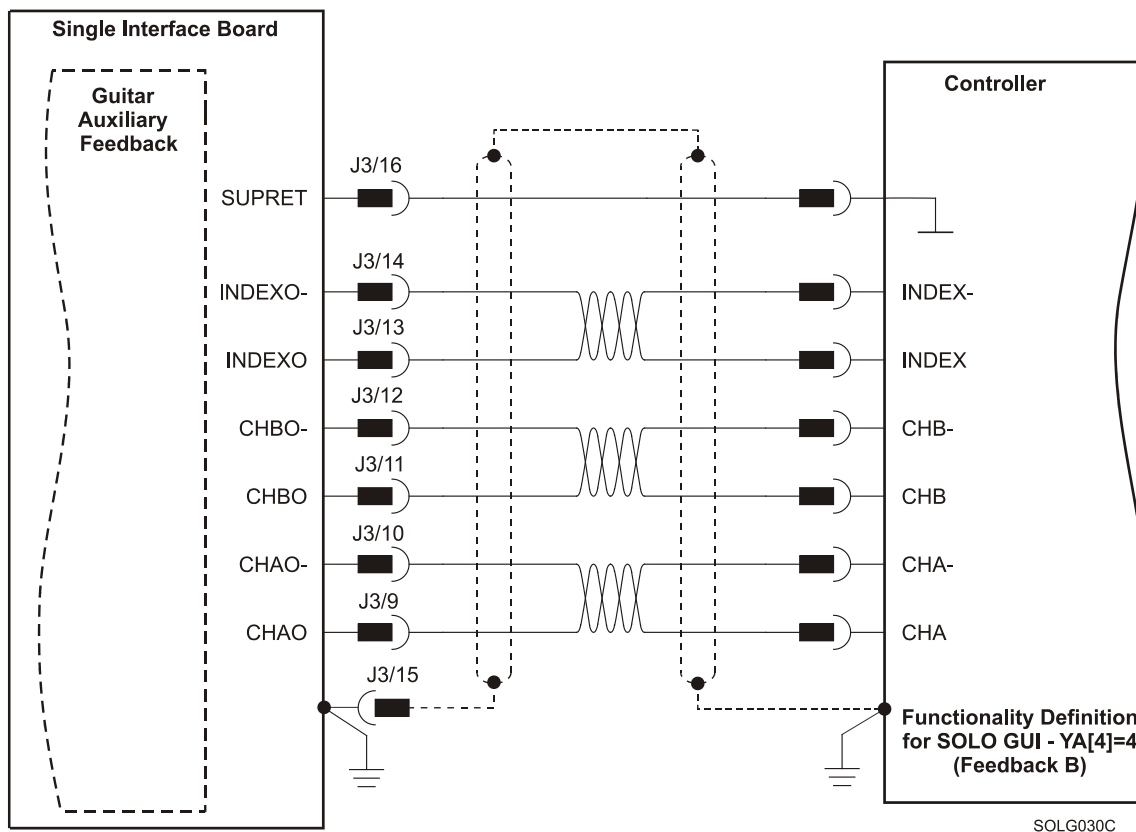
- A Resolver, Analog Encoder or Potentiometer and Tachometer is used as a Main Feedback device.
- The Solo Guitar is used as a current amplifier to provide position data to the position controller.
- The Solo Guitar is used in velocity mode, to provide position data to the position controller.
- The Solo Guitar is used as a master in Follower or ECAM mode.

Below are the signals on the Auxiliary Feedback ports when the Solo Guitar Auxiliary Feedback port is set up for emulated output of the Main Feedback device (Resolver or Analog Incremental Encoder only).

Port	Pin (J3)	Signal	Function
PWR	1	+5V	Encoder supply voltage
PWR	2	COMRET	Common return
B1	3	NA	When YA[4]=4 the B1 port is not available
B1	4	NA	When YA[4]=4 the B1 port is not available
B1	5	NA	When YA[4]=4 the B1 port is not available
B1	6	NA	When YA[4]=4 the B1 port is not available
B1	7	NA	When YA[4]=4 the B1 port is not available
B1	8	NA	When YA[4]=4 the B1 port is not available
B2	9	CHAO	Buffered Channel A output
B2	10	CHAO-	Buffered Channel A complement output
B2	11	CHBO	Buffered channel B output
B2	12	CHBO-	Buffered channel B complement output
B2	13	INDEXO	Buffered Index output
B2	14	INDEXO-	Buffered Index complement output
PWR	15	PE	Protective Earth
PWR	16	COMRET	Common return



**Table 6: Emulated Encoder Output on the Auxiliary Feedback Port B2 - Pin Assignments**



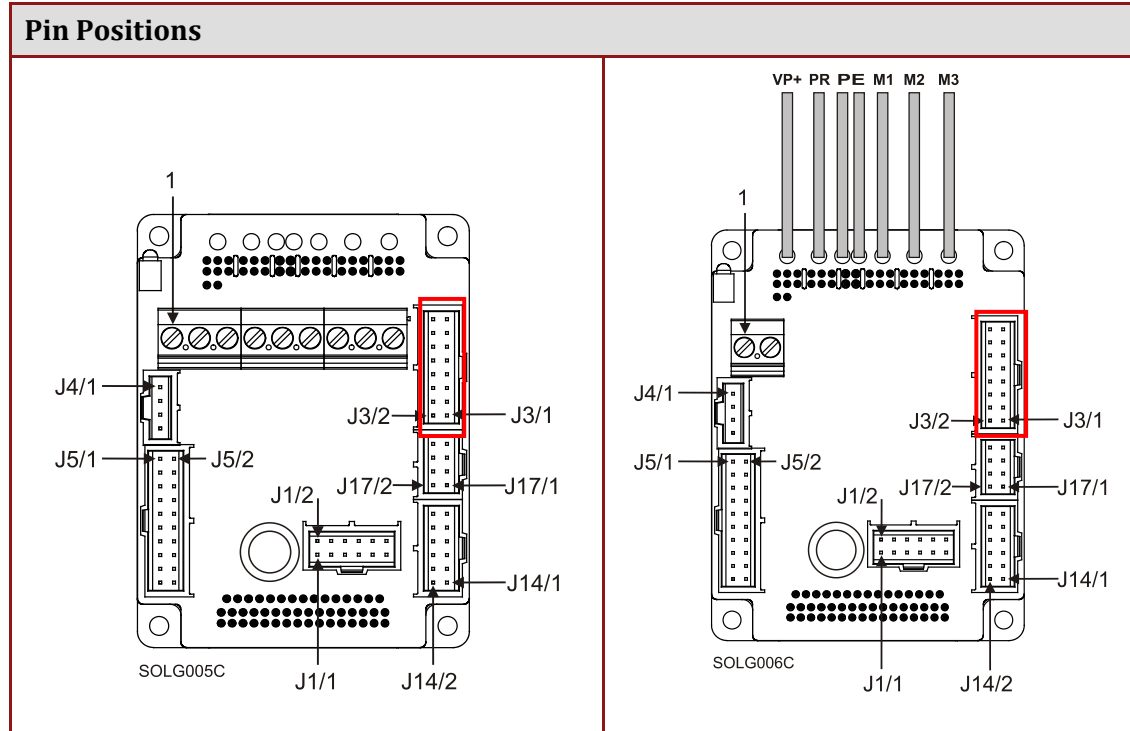
**Figure 17: Emulated Encoder Direct Output – Acceptable Connection Diagram**

### 3.7.3. Auxiliary Feedback – Differential Encoder Input Option (YA[4]=2)

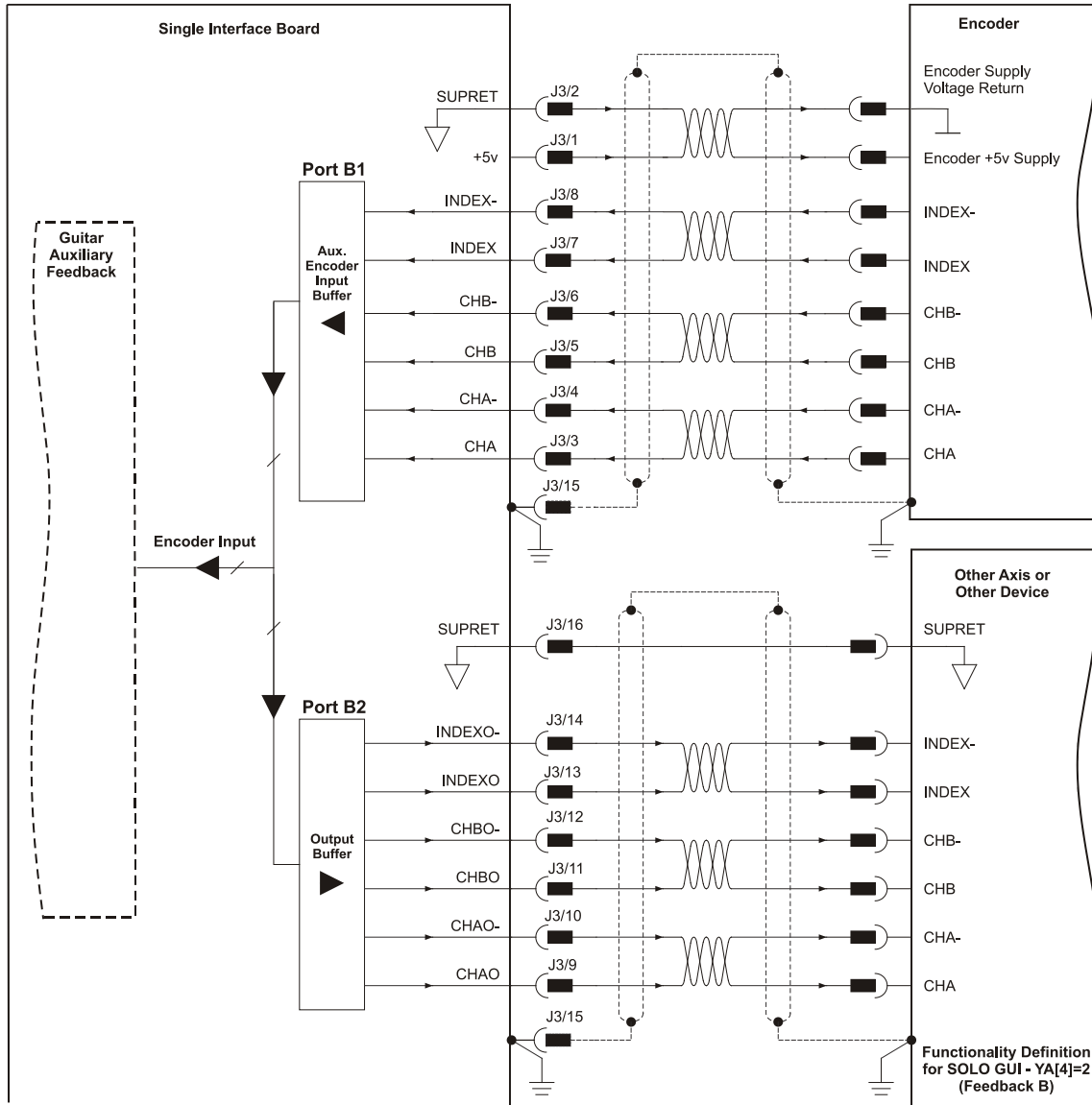
The Solo Guitar can be used as a slave by receiving the position data (on Port B1) of the master encoder in Follower or ECAM mode. In this mode, Port B2 provides **differential buffered Auxiliary outputs of B1** for the next slave axis in Follower or ECAM mode.

Below are the signals on the Auxiliary Feedback ports when the Solo Guitar Auxiliary Feedback port is set up to run as a differential Auxiliary input:

Port	Pin (J3)	Signal	Function
PWR	1	+5V	Encoder supply voltage
PWR	2	COMRET	Common return
B1	3	CHA	Auxiliary channel A input
B1	4	CHA-	Auxiliary channel A complement input
B1	5	CHB	Auxiliary channel B input
B1	6	CHB-	Auxiliary channel B complement input
B1	7	INDEX	Auxiliary Index input
B1	8	INDEX-	Auxiliary Index complement input
B2	9	CHAO	Buffered Channel A output
B2	10	CHAO-	Buffered channel A complement output
B2	11	CHBO	Buffered channel B output
B2	12	CHBO-	Buffered channel B complement output
B2	13	INDEXO	Buffered Index output
B2	14	INDEXO-	Buffered Index complement output
PWR	15	PE	Protective Earth
PWR	16	COMRET	Common return



**Table 7: Differential Auxiliary Encoder Input Option along with Differential Encoder Outputs on Auxiliary Feedback - Pin Assignments**



SOLG031C

Figure 18: Differential Auxiliary Input Option on Auxiliary Feedback - Connection Diagram

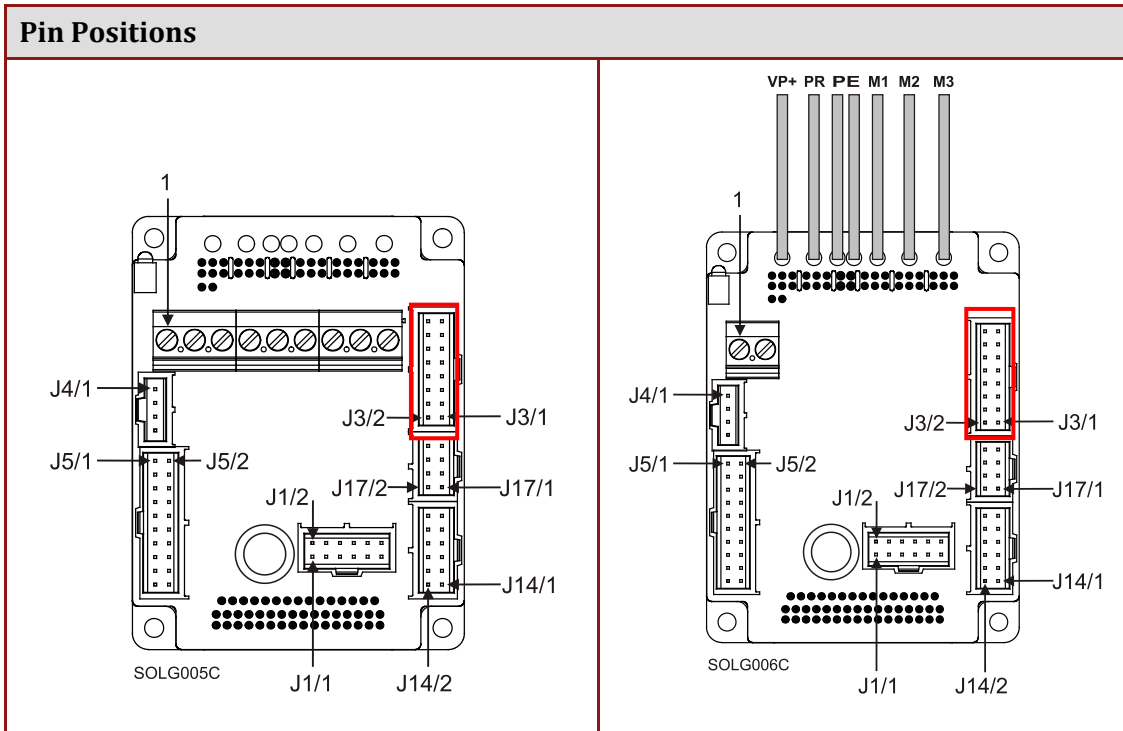
### 3.7.4. Auxiliary Feedback – Differential Pulse-and-Direction Input Option (YA[4]=0)

This mode is used for input of differential pulse-and-direction position commands on Port B1. In this mode Port B2 provides **differential buffered pulse-and-direction outputs of B1** for another axis.

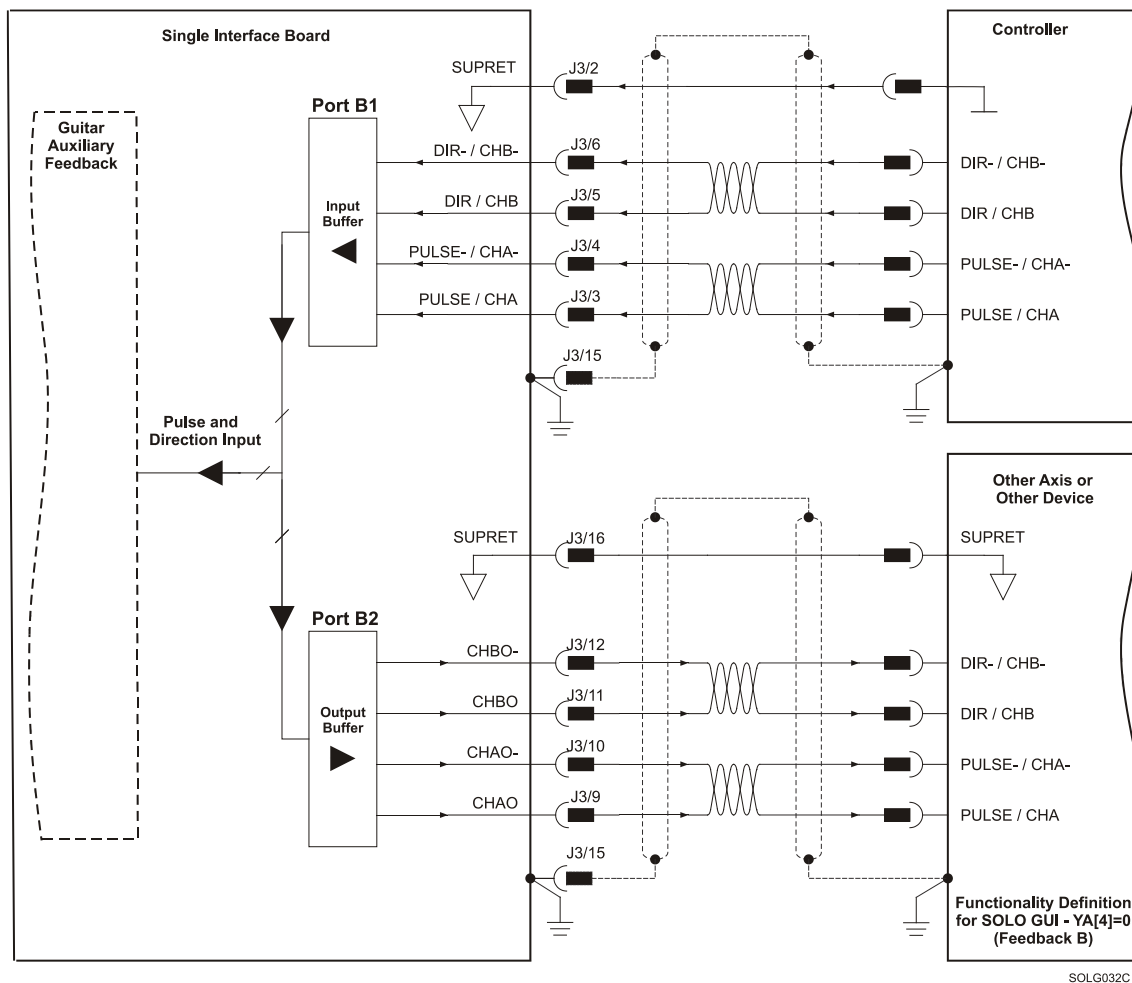
Below are the signals on the Auxiliary Feedback ports when set up to run as a differential pulse-and-direction input:

Port	Pin (J3)	Signal	Function
PWR	1	+5V	Encoder supply voltage
PWR	2	COMRET	Common return
B1	3	CHA	Auxiliary pulse input
B1	4	CHA-	Auxiliary pulse complement input
B1	5	CHB	Auxiliary direction input
B1	6	CHB-	Auxiliary direction complement input
B1	7	NA	Do not connect this pin
B1	8	NA	Do not connect this pin
B2	9	CHAO	Buffered pulse output
B2	10	CHAO-	Buffered pulse complement output
B2	11	CHBO	Buffered direction output
B2	12	CHBO-	Buffered direction complement output
B2	13	NA	Do not connect this pin
B2	14	NA	Do not connect this pin
PWR	15	PE	Protective Earth
PWR	16	COMRET	Common return
Pin positions in diagram below.			





**Table 8: Pulse-and-Direction Pin Assignments on Auxiliary Feedback**



SOLG032C

**Figure 19: Pulse-and-Direction Input Option on Auxiliary Feedback - Connection Diagram**

### 3.8. I/Os

The Solo Guitar has 5 Digital Inputs, 4 Digital Outputs and 1 Analog Input.

#### 3.8.1. Digital Input

Each of the pins below can function as an independent input.

Pin (J5)	Signal	Function
1	IN2	Programmable input 2 (general purpose, RLS, FLS, INH)
2	INRET2	Programmable input 2 return
3	IN4	Programmable input 4 (general purpose, RLS, FLS, INH)
4	IN3	Programmable input 3 (general purpose, RLS, FLS, INH)
5	IN5	Hi-Speed Programmable input 5 (event capture, Main Home, general purpose, RLS, FLS, INH)
6	INRET	Programmable input return
7	IN6	Hi-Speed Programmable input 6 (event capture, Auxiliary Home, general purpose, RLS, FLS, INH)
8	INRET	Programmable input return

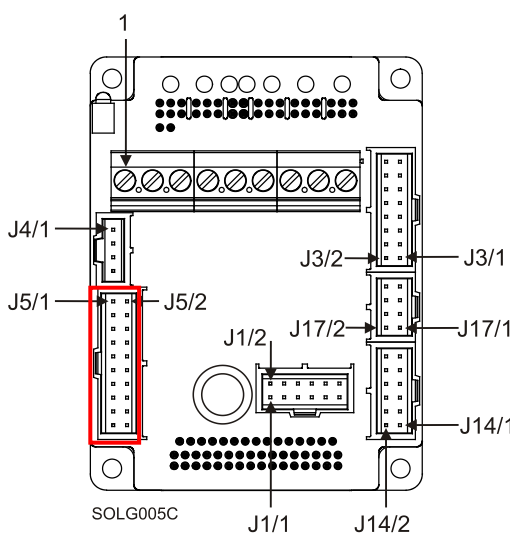
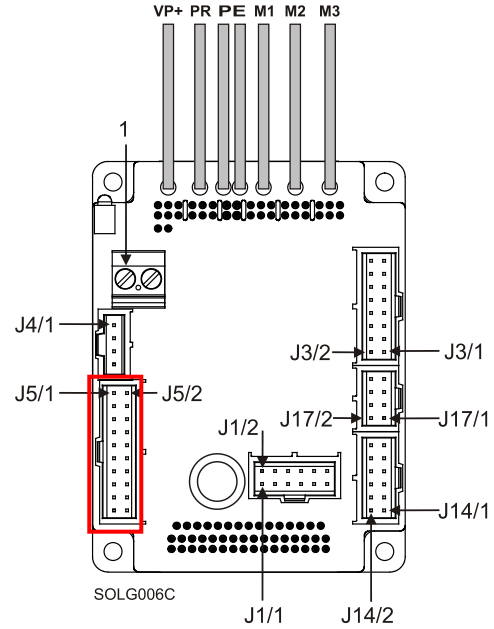
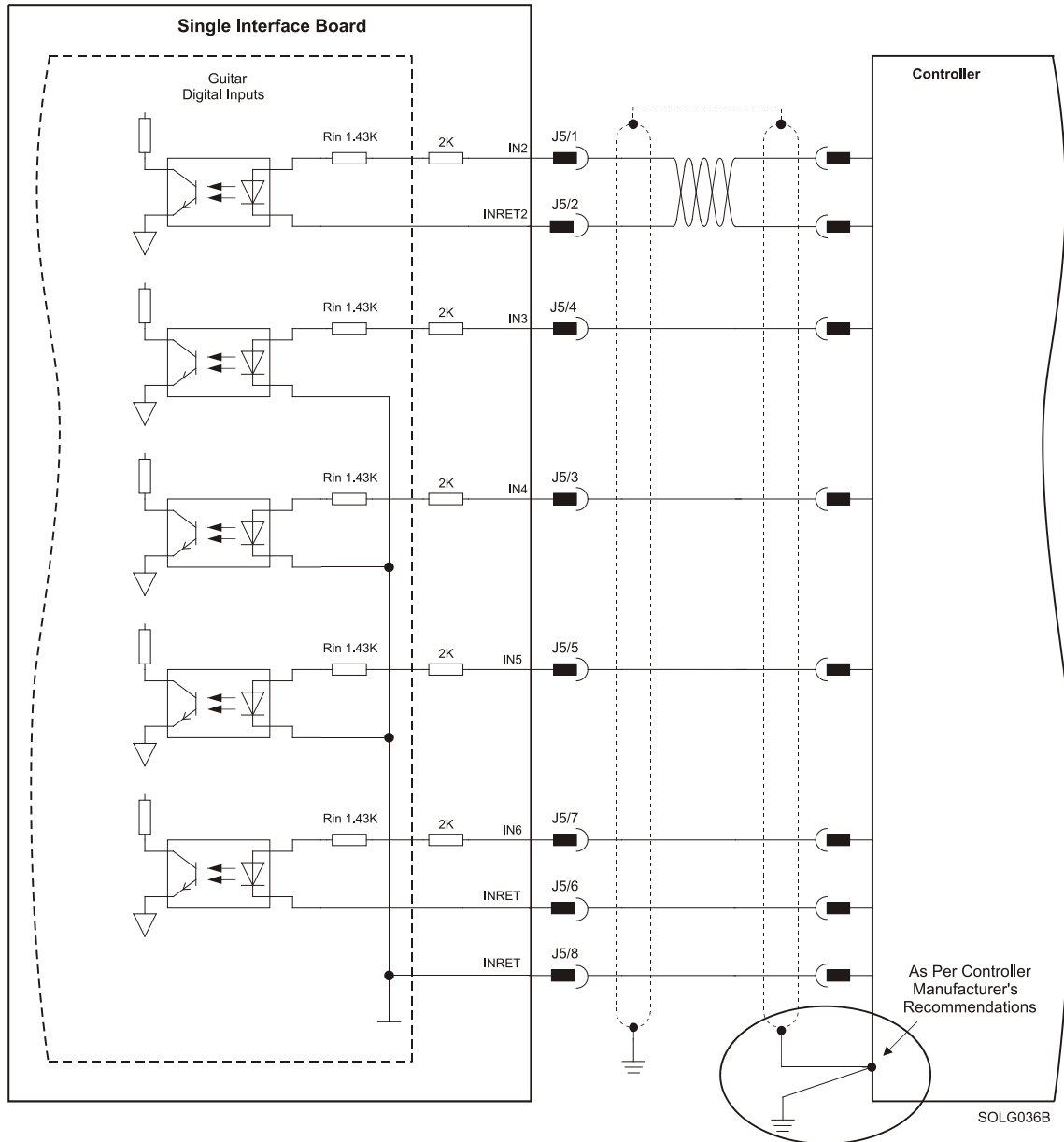
Pin Positions	
 <p>SOLG005C</p>	 <p>SOLG006C</p>

Table 9: Digital Input Pin Assignments



**Figure 20: Digital Input Connection Diagram**

### 3.8.2. Digital Output

Pin (J5)	Signal	Function
9	VDDIN	Digital output supply
10	OUT1	Programmable digital output 1
11	VDDIN	Digital output supply
12	OUT2	Programmable digital output 2
13	VDDRET	Digital output supply return
14	OUT3	Programmable digital output 3
15	VDDRET	Digital output supply return
16	OUT4	Programmable digital output 4

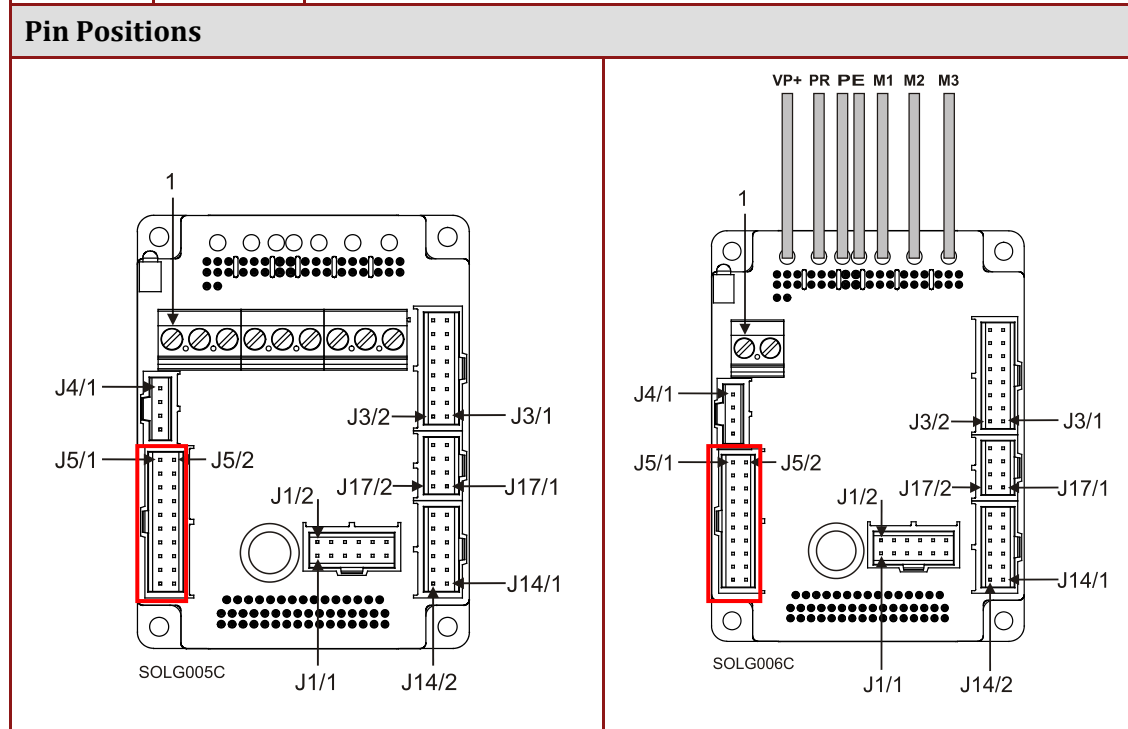
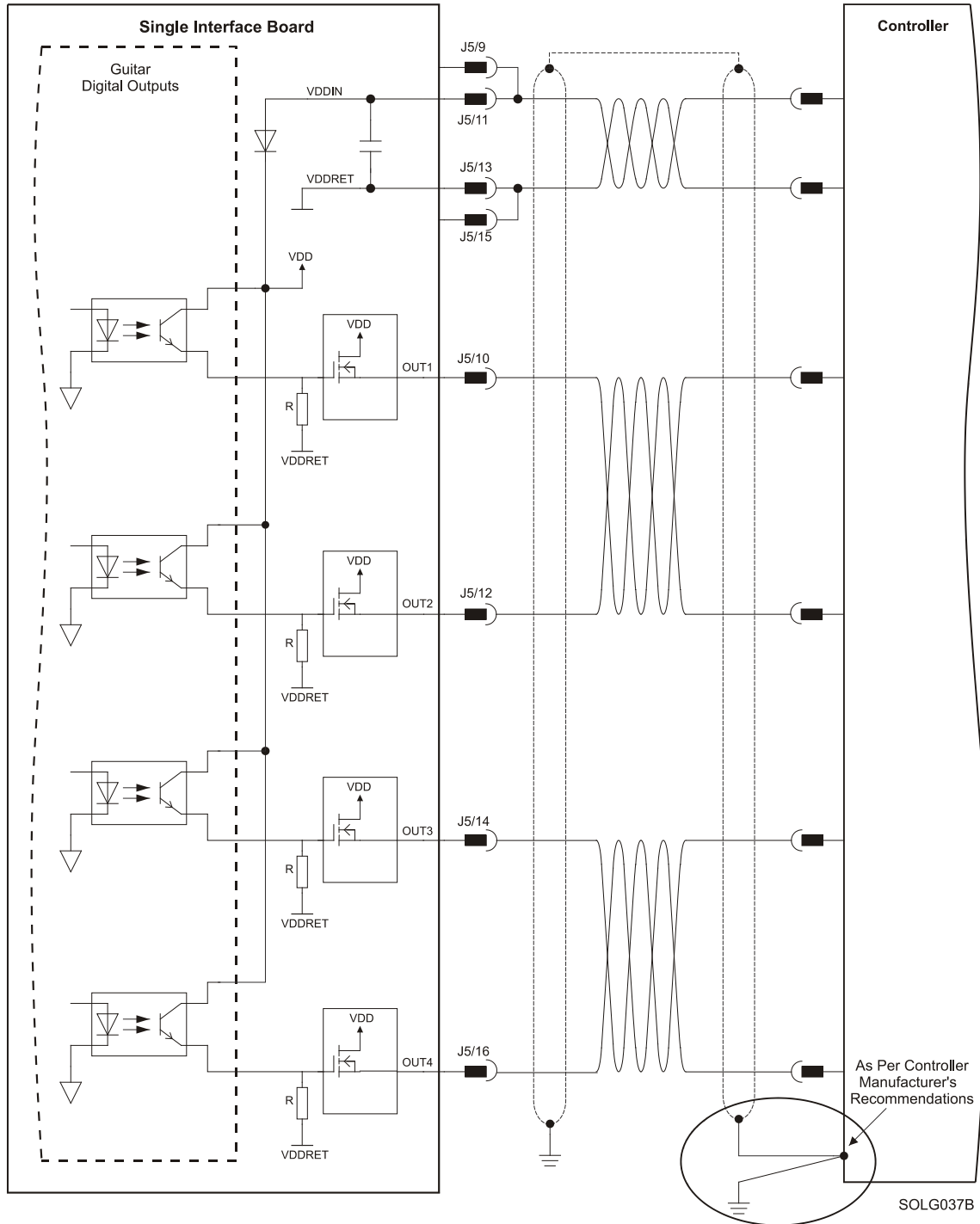


Table 10: Digital Output Pin Assignments



**Figure 21: Digital Output Connection Diagram**

### 3.8.3. Analog Input

Pin (J5)	Signal	Function
18	ANLIN1+	Analog input 1+
20	ANLIN1-	Analog input 1-
17	ANLRET	Analog return

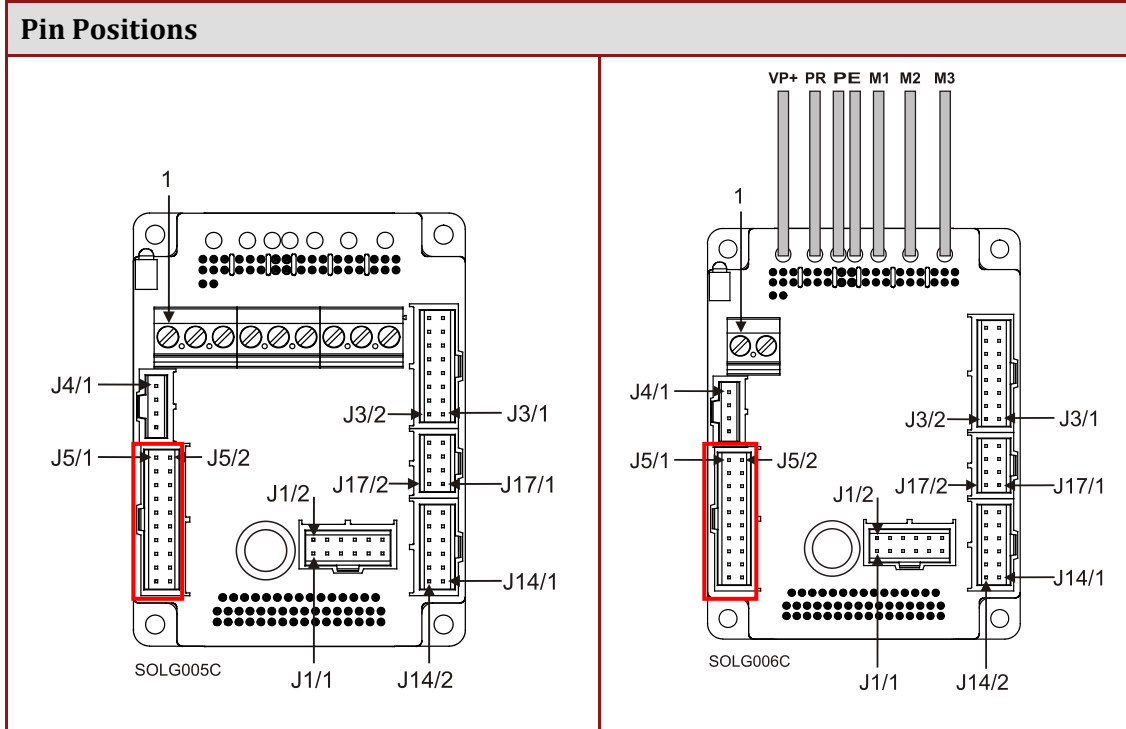


Table 11: Analog Input Pin Assignments

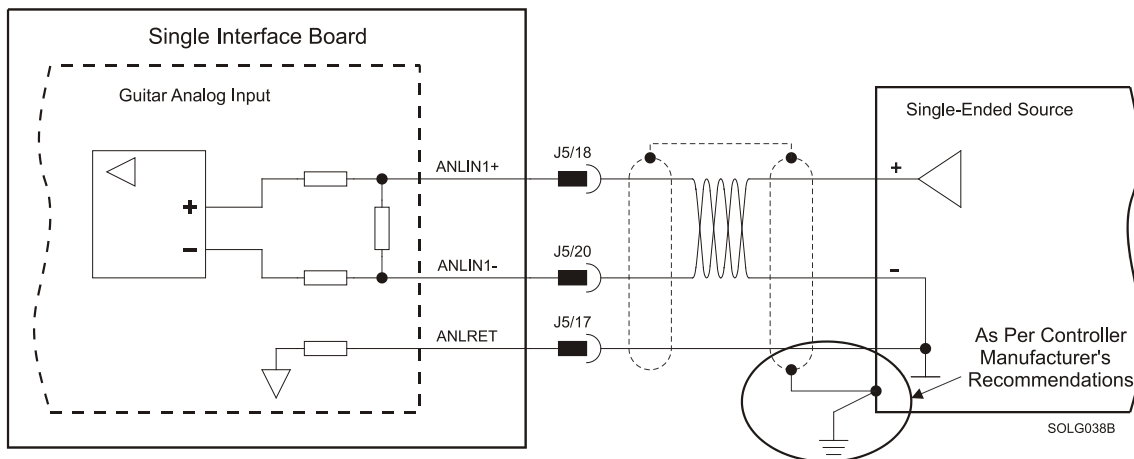


Figure 22: Analog Input with Single-Ended Source

### 3.9. Communications

The communication interface may differ according to the user’s hardware. The Solo Guitar can communicate using the following options:

- RS-232, full duplex
- CAN

**RS-232** communication requires a standard, commercial 3-core null-modem cable connected from the Solo Guitar to a serial interface on the PC. The interface is selected and set up in the Composer software.

In order to benefit from **CAN** communication, the user must have an understanding of the basic programming and timing issues of a CAN network.

For ease of setup and diagnostics of CAN communication, RS-232 and CAN can be used simultaneously.

#### 3.9.1. RS-232 Communication

To connect the RS-232 communication cable

1. Connect the shield to the ground of the host (PC). Usually, this connection is soldered internally inside the connector at the PC end. You can use the drain wire to facilitate connection.
2. The RS-232 communication port is non-isolated.

Pin (J1)	Signal	Function
9	RS232_Tx	RS-232 transmit
10	RS232_Rx	RS-232 receive
11	RS232_COMRET	Communication return

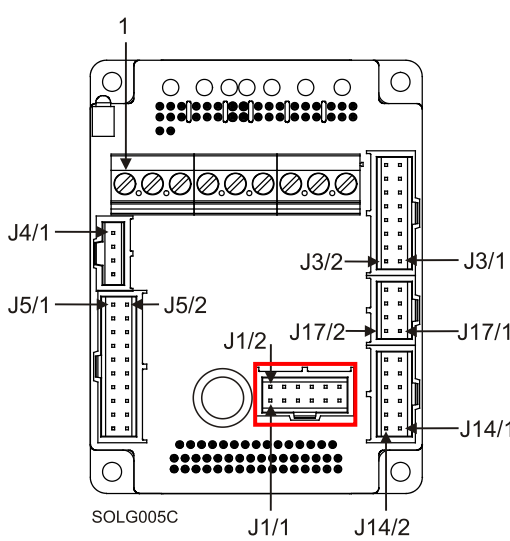
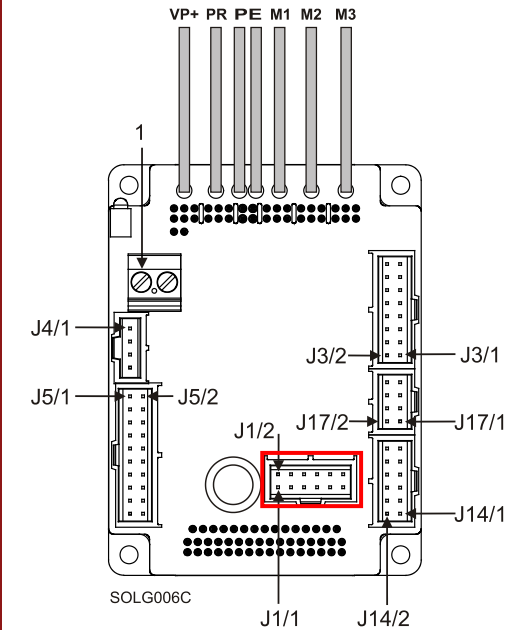
Pin Positions	
 <p>SOLG005C</p>	 <p>SOLG006C</p>

Table 12: RS-232 Pin Assignments

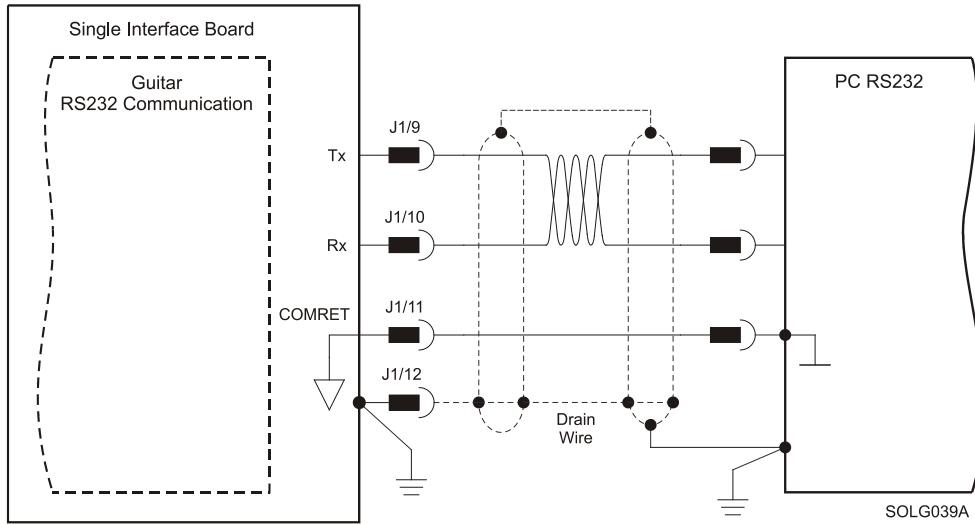


Figure 23: RS-232 Connection Diagram



### 3.9.2. CAN Communication

To connect the CAN communication cable

1. Connect the shield to the ground of the host (PC). Usually, this connection is soldered internally inside the connector at the PC end. You can use the drain wire to facilitate connection.
2. Make sure to have a 120-Ω resistor termination at each of the two ends of the network cable.
3. The Solo Guitar's CAN port is **non-isolated**.

Pin (J1) CANIN	Pin (J1) CANOUT	Signal	Function
1	5	CAN_L	CAN_L busline (dominant low)
2	6	CAN_H	CAN_H busline (dominant high)
3	7	CAN_GND	CAN ground

Pin positions in diagram below.

#### Pin Positions

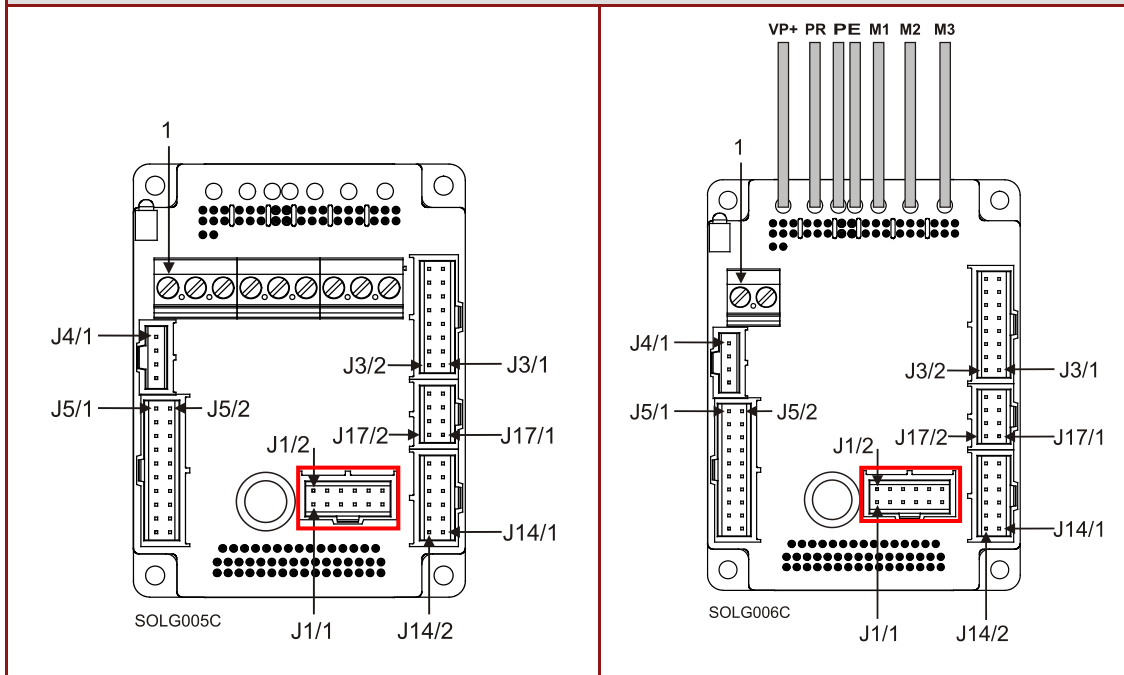
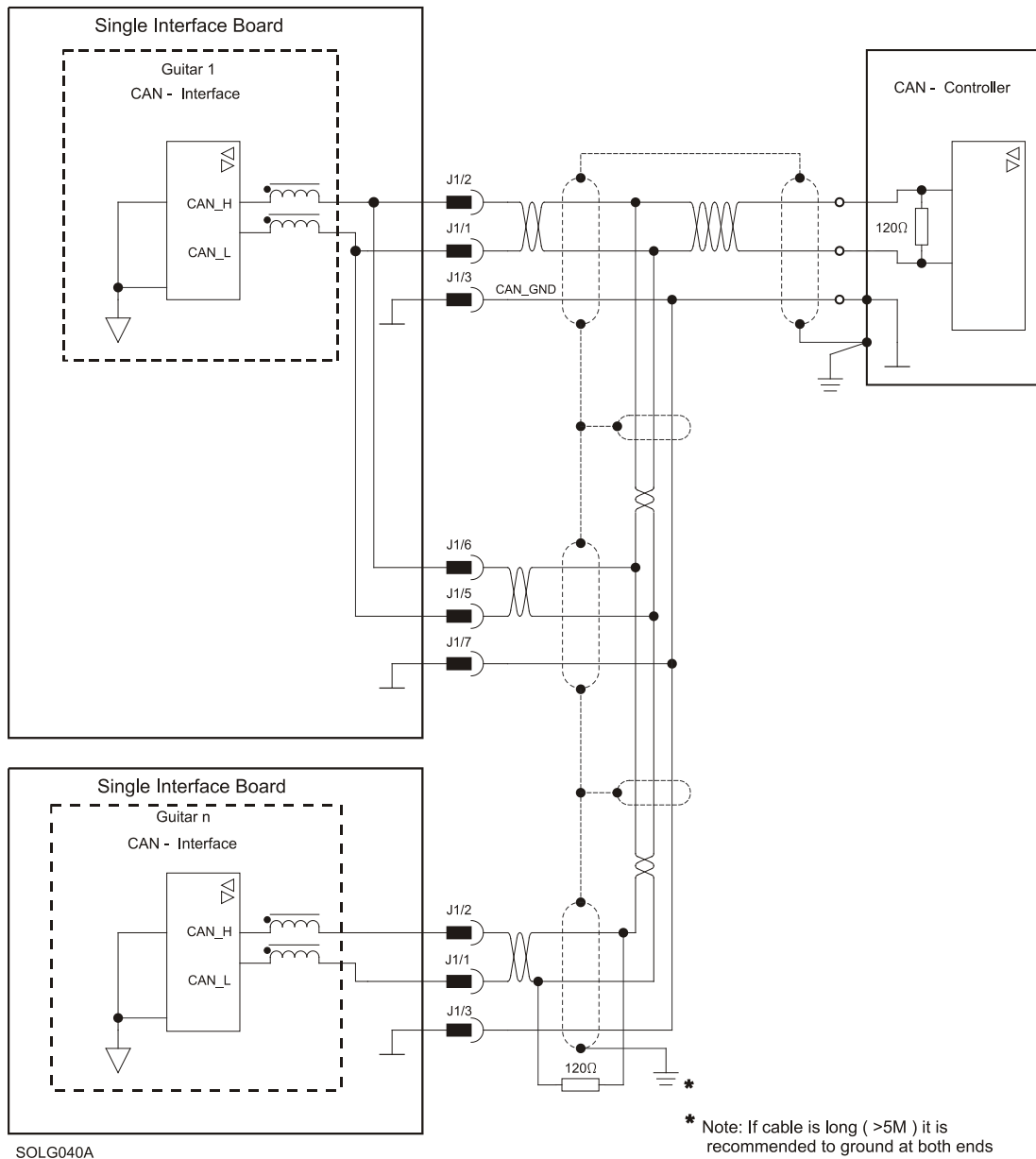


Table 13: CAN - Pin Assignments



**Figure 24: CAN Network Diagram**



**Caution:** When installing CAN communication, ensure that each servo drive is allocated a unique ID. Otherwise, the CAN network may hang.

### 3.10. Powering Up

After the Solo Guitar is connected to its device, it is ready to be powered up.



**Caution:** Before applying power, ensure that the DC supply is within the specified range and that the proper plus-minus connections are in order.

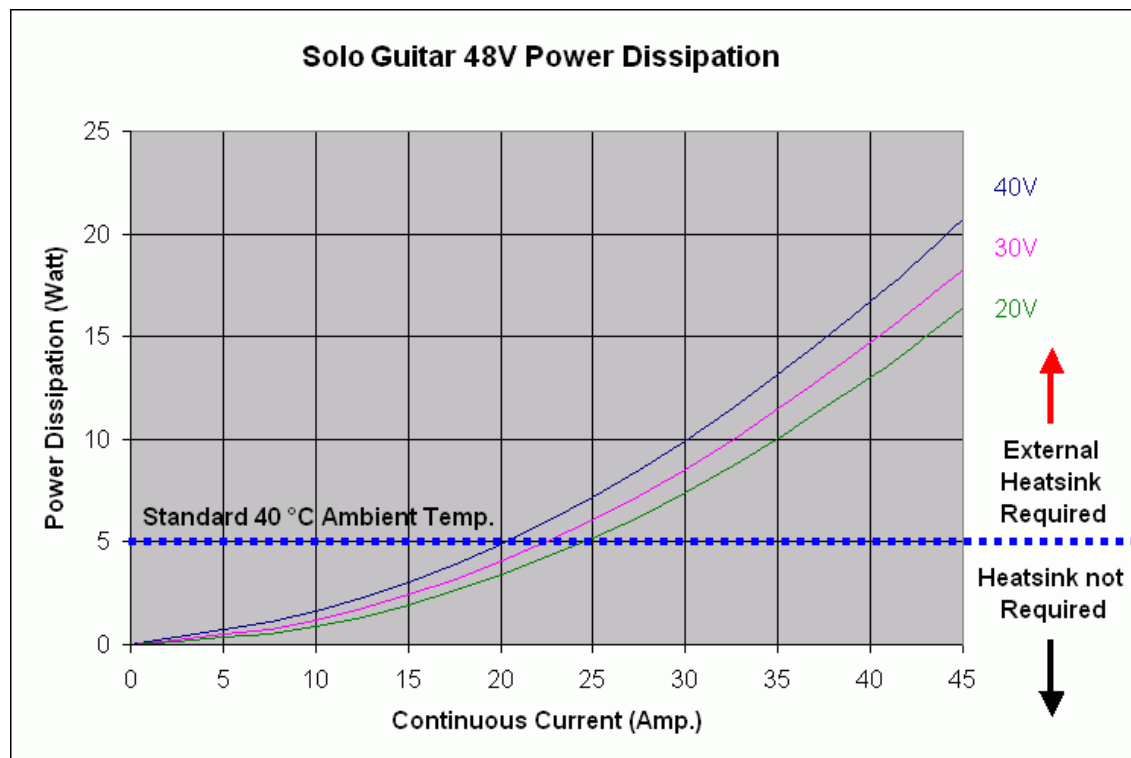
### 3.11. Initializing the System

After the Solo Guitar has been connected and mounted, the system must be set up and initialized. This is accomplished using the *Composer*, Elmo's Windows-based software application. Install the application and then perform setup and initialization according to the directions in the *Composer Software Manual*.

### 3.12. Heat Dissipation

The best way to dissipate heat from the Solo Guitar is to mount it so that its heatsink faces up. For best results leave approximately 10 mm of space between the Solo Guitar's heatsink and any other assembly.

The Heat Dissipation data is shown graphically below:







### 3.12.1. How to Use the Charts

The charts above are based upon theoretical worst-case conditions. Actual test results show 30% to 50% better power dissipation.

To determine if your application needs a heatsink:

1. Allow maximum heatsink temperature to be 80 °C or less.
2. Determine the ambient operating temperature of the Solo Guitar.
3. Calculate the allowable temperature increase as follows:  
For an ambient temperature of 40 °C,  $\Delta T = 80\text{ °C} - 40\text{ °C} = 40\text{ °C}$ .
4. Use the chart to find the actual dissipation power of the drive. Follow the voltage curve to the desired output current and then find the dissipated power.
5. If the dissipated power is below 5 W the Solo Guitar will need no additional cooling.

**Note:** The chart above shows that no heatsink is needed when the heatsink temperature is 80 °C, ambient temperature is 40 °C and heat dissipated is 5 Watts.

## ***Chapter 4: Technical Specifications***

This chapter provides detailed technical information regarding the Solo Guitar. This includes its dimensions, power ratings, the environmental conditions under which it can be used, the standards to which it complies and other specifications.

### **4.1. Features**

The Solo Guitar's features determine how it controls motion, as well as how it processes host commands, feedback and other input.

#### **4.1.1. Motion Control Modes**

- Current/Torque - up to 16 kHz sampling rate
- Velocity - up to 8 kHz sampling rate
- Position - up to 4 kHz sampling rate

#### **4.1.2. Advanced Positioning Control Modes**

- PTP, PT, PVT, ECAM, Follower, Dual Loop, Current Follower
- Fast event capturing inputs
- Fast output compare (OC)
- Motion Commands: Analog current and velocity, pulse-width modulation (PWM) current and velocity, digital (SW) and Pulse and Direction

#### **4.1.3. Advanced Filters and Gain Scheduling**

- “On-the-Fly” gain scheduling of current and velocity
- Velocity and position with “1-2-4” PIP controllers
- Automatic commutation alignment
- Automatic motor phase sequencing

#### **4.1.4. Fully Programmable**

- Third generation programming structure with motion commands – “Composer”
- Event capturing interrupts
- Event triggered programming

#### 4.1.5. Feedback Options

- Incremental Encoder – up to 20 Mega-Counts (5 Mega-Pulse) per second
- Digital Halls – up to 2 kHz
- Incremental Encoder with Digital Halls for commutation – up to 20 Mega-Counts per second for encoder
- Interpolated Analog (Sine/Cosine) Encoder – up to 250 kHz (analog signal)
  - Internal Interpolation - up to x4096
  - Automatic Correction of amplitude mismatch, phase mismatch, signal offset
  - Emulated encoder outputs, single-ended, unbuffered of the Analog encoder
- Analog Hall Sensor
- Resolver
  - Programmable 10 to 15 bit resolution
  - Up to 512 revolutions per second (RPS)
  - Emulated encoder outputs, single-ended, unbuffered of the Resolver
- Auxiliary Encoder inputs (ECAM, follower, etc.) single-ended, unbuffered
- Tachometer & Potentiometer
- The Solo Guitar can provide power (5 V, 2x200 mA max) for Encoders, Resolver or Halls.

#### 4.1.6. Input/Output

- One **Analog Input** – up to 14-bit resolution
- Five separate programmable **Digital Inputs**, optically isolated (two of which are fast event capture inputs):
  - Inhibit/Enable motion
  - Software and analog reference stop
  - Motion limit switches
  - Begin on input
  - Abort motion
  - Homing
  - General-purpose
- Four separate programmable **Digital Outputs**, optically isolated (open source) one with fast output compare (OC):
  - Brake Control
  - Amplifier fault indication
  - General-purpose
  - Servo enable indication
- Pulse and Direction inputs (Differential)
- PWM current command output for torque and velocity

#### **4.1.7. Built-In Protection**

- Software error handling
- Abort (hard stops and soft stops)
- Status reporting
- Protection against:
  - Shorts between motor power outputs
  - Shorts between motor power outputs and power input/return
  - Failure of internal power supplies
  - Over-heating
  - Continuous temperature measurement. Temperature can be read on the fly; a warning can be initiated x degrees before temperature disable is activated.
  - Over/Under voltage
  - Loss of feedback
  - Following error
  - Current limits

#### **4.1.8. Accessories**

- Heat sinks (TBD)

#### **4.1.9. Status Indication**

- Output for a bi-color LED

#### **4.1.10. Automatic Procedures**

- Commutation alignment
- Phase sequencing
- Current loop offset adjustment
- Current loop gain tuning
- Current gain scheduling
- Velocity loop offset adjustment
- Velocity gain tuning
- Velocity gain scheduling
- Position gain tuning



## 4.2. Solo Guitar Dimensions

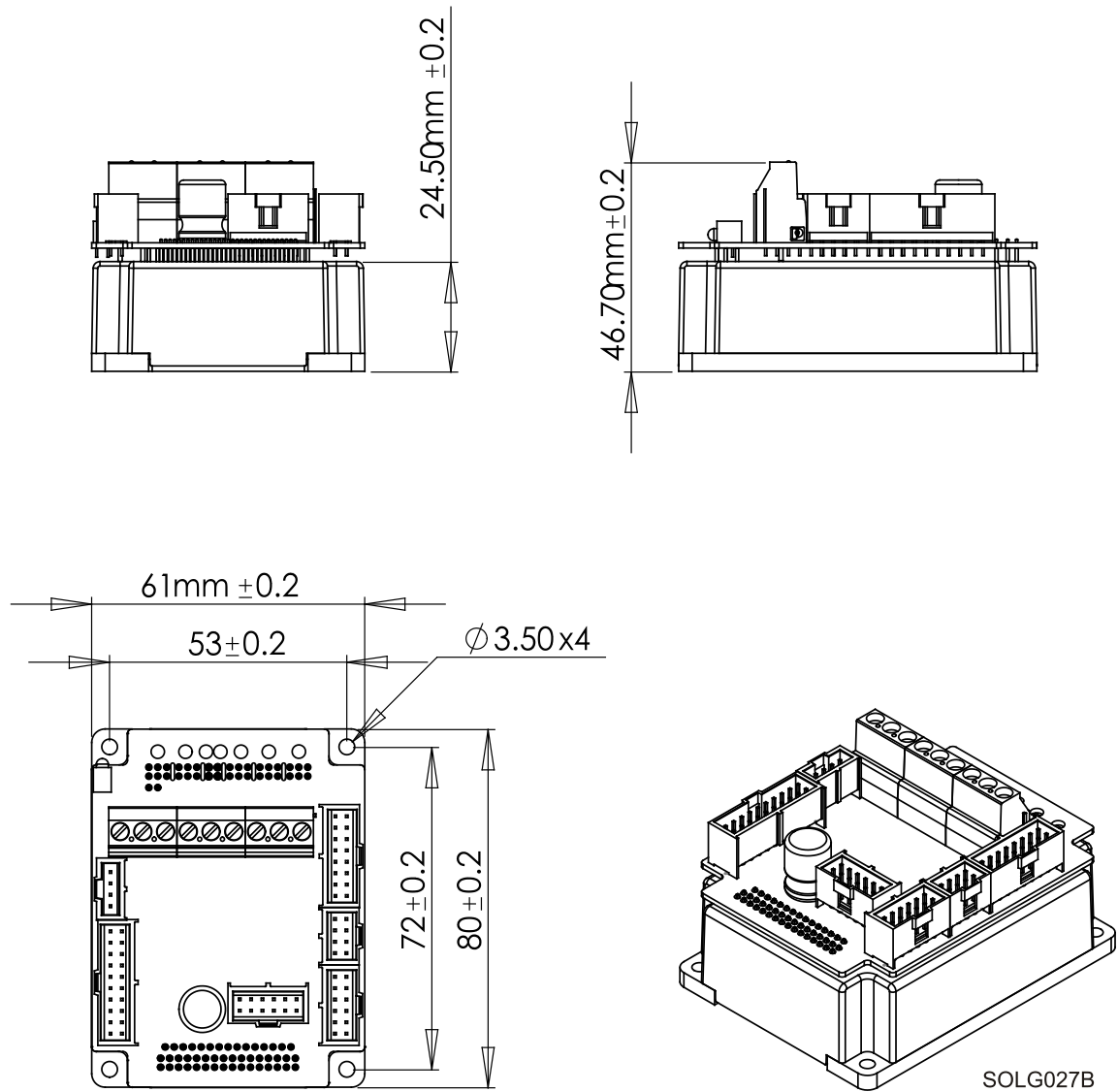


Figure 25: Solo Guitar Dimensions

### 4.3. Power Ratings

Feature	Units	Units															
		20/48	35/48	20/60	25/60	35/60	20/100	25/100	3/200	6/200	10/200	17/200	R45/48	R45/60	R35/100	R30/200	
Minimum supply voltage	VDC	11	11	14		23		46				11	14	23	46		
Nominal supply voltage	VDC	42	42	50		85		170				42	50	85	170		
Maximum supply voltage	VDC	48	48	59		95		195				48	59	95	195		
Maximum continuous power output	W	400	1300	960	1200	1700	1600	2000	480	960	1600	2700	1700	2200	2800	4800	
Efficiency at rated power (at nominal conditions)	%	> 97															
Maximum output voltage		97% of DC bus voltage at f=22 kHz															
Amplitude sinusoidal/DC continuous current	A	20	35	20	25	35	20	25	3	6	10	17	45	45	35	30	
Sinusoidal continuous RMS current limit (Ic)	A	14.1	25	14.1	17.7	25	14.1	17.7	2.12	4.2	7	12	32	31.8	24.8	21.2	
Peak current limit	A	2 x Ic											No peak				
Weight	g (oz)	200 g (7.05 oz)															
Dimensions	mm (in)	80 x 61 x 46.7 (3.15" x 2.4" x 1.84")															
Digital in/Digital out/Analog in		5/4/1															

**Note on current ratings:** The current ratings of the Solo Guitar are given in units of DC amperes (ratings that are used for trapezoidal commutation or DC motors). The RMS (sinusoidal commutation) value is the DC value divided by 1.41.

#### 4.3.1. Auxiliary Supply

Feature	Details
Auxiliary power supply	<i>Isolated DC source only</i>
Auxiliary supply input voltage	12 VDC to 195 VDC
Auxiliary supply input power	< 7.5 VA (this includes the 5 V/2x200 mA load for the main and auxiliary encoders)

## 4.4. Environmental Conditions

Feature	Details
<b>Operating ambient temperature according to IEC60068-2-2</b>	0 °C to 40 °C (32 °F to 104 °F)
<b>Storage temperature</b>	-20 °C to +85 °C ( -4 °F to +185 °F)
<b>Maximum non-condensing humidity according to IEC60068-2-78</b>	95%
<b>Maximum Operating Altitude</b>	2,000 m (6562 feet)
<b>Mechanical Shock according to IEC60068-2-27</b>	15g / 11ms Half Sine
<b>Vibration according to IEC60068-2-6</b>	5 Hz ≤ f ≤ 10 Hz: ±10mm 10 Hz ≤ f ≤ 57 Hz: 4G 57 Hz ≤ f ≤ 500 Hz:5G

## 4.5. Control Specifications

### 4.5.1. Current Loop

Feature	Details
Controller type	Vector, digital
Compensation for bus voltage variations	“On-the-fly” automatic gain scheduling
Motor types	<ul style="list-style-type: none"> <li>• AC brushless (sinusoidal)</li> <li>• DC brushless (trapezoidal)</li> <li>• DC brush</li> <li>• Linear motors</li> <li>• “Voice” coils</li> </ul>
Current control	<ul style="list-style-type: none"> <li>• Fully digital</li> <li>• Sinusoidal with vector control</li> <li>• Programmable PI control filter based on a pair of PI controls of AC current signals and constant power at high speed</li> </ul>
Current loop bandwidth	< 2.5 kHz
Current sampling time	Programmable 70 to 100 μsec
Current sampling rate	Up to 16 kHz; default 11 kHz

#### 4.5.2. Velocity Loop

Feature	Details
Controller type	PI
Velocity control	<ul style="list-style-type: none"> <li>• Fully digital</li> <li>• Programmable PI and FFW control filters</li> <li>• "On-the-fly" gain scheduling</li> <li>• Automatic, manual and advanced manual tuning</li> </ul>
Velocity and position feedback options	<ul style="list-style-type: none"> <li>• Incremental Encoder</li> <li>• Digital Halls</li> <li>• Interpolated Analog (Sine/Cosine) Encoder (optional)</li> <li>• Resolver (optional)</li> <li>• Tachometer and Potentiometer (optional)</li> </ul> <p><b>Note:</b> With all feedback options, 1/T with automatic mode switching is activated (gap, frequency and derivative).</p>
Velocity loop bandwidth	< 350 Hz
Velocity sampling time	140 to 200 $\mu$ sec (2x current loop sample time)
Velocity sampling rate	Up to 8 kHz; default 5.5 kHz
Velocity command options	<ul style="list-style-type: none"> <li>• Analog</li> <li>• Internally calculated by either jogging or step</li> </ul> <p><b>Note:</b> All software-calculated profiles support on-the-fly changes.</p>

### 4.5.3. Position Loop

Feature	Details
Controller type	"1-2-4" PIP
Position command options	<ul style="list-style-type: none"> <li>• Software</li> <li>• Pulse and Direction</li> <li>• Analog Potentiometer</li> </ul>
Position loop bandwidth	< 80 Hz
Position sampling time	280 to 400 $\mu$ sec (4x current loop sample time)
Position sampling rate	Up to 4 kHz; default 2.75 kHz

## 4.6. Feedbacks

### 4.6.1. Feedback Supply Voltage

The Solo Guitar has two feedback ports (Main and Auxiliary). The Solo Guitar supplies voltage only to the main feedback device and to the auxiliary feedback device if needed.

Feature	Details
Main encoder supply voltage	5 V $\pm$ 5% @ 200 mA maximum
Auxiliary encoder supply voltage	5 V $\pm$ 5% @ 200 mA maximum

## 4.6.2. Main Feedback Options

The Solo Guitar can receive and process feedback input from diverse types of devices.

### 4.6.2.1. Incremental Encoder Input

Feature	Details
Encoder format	<ul style="list-style-type: none"> <li>• A, B and Index</li> <li>• Differential</li> <li>• Quadrature</li> </ul>
Interface	RS-422
Input resistance	Differential: 120 Ω (TBD)
Maximum incremental encoder frequency	Maximum absolute: 5 MHz pulses
Minimum quadrature input period ( $P_{IN}$ )	112 nsec
Minimum quadrature input high/low period ( $P_{HL}$ )	56 nsec
Minimum quadrature phase period ( $P_{PH}$ )	28 nsec
Maximum encoder input voltage range	Common mode: $\pm 7$ V Differential mode: $\pm 7$ V

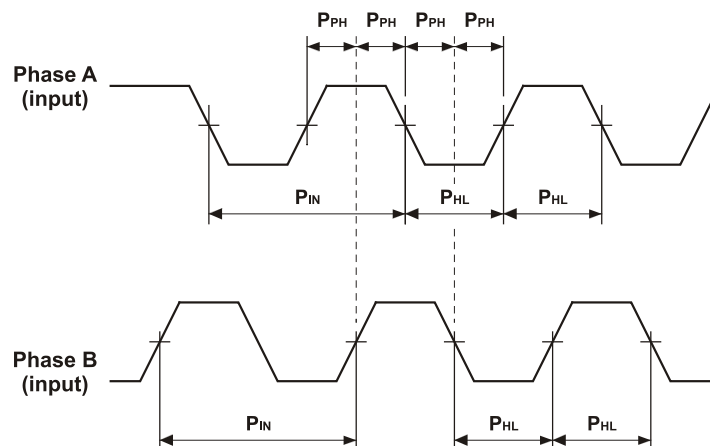


Figure 26: Main Feedback - Encoder Phase Diagram

#### 4.6.2.2. Digital Halls

Feature	Details
Halls inputs	<ul style="list-style-type: none"> <li>• <math>H_A, H_B, H_C</math>.</li> <li>• Single ended inputs</li> <li>• Built in hysteresis of 1 V for noise immunity</li> </ul>
Input voltage	Nominal operating range: $0\text{ V} < V_{\text{In\_Hall}} < 5\text{ V}$ Maximum absolute: $-1\text{ V} < V_{\text{In\_Hall}} < 15\text{ V}$ High level input voltage: $V_{\text{InHigh}} > 2.5\text{ V}$ Low level input voltage: $V_{\text{InLow}} < 1\text{ V}$
Input current	Sink current (when input pulled to the common): 5 mA
Maximum frequency	$f_{\text{MAX}} : 2\text{ kHz}$

#### 4.6.2.3. Interpolated Analog (Sine/Cosine) Encoder

Feature	Details
Analog encoder format	<ul style="list-style-type: none"> <li>• Sine and Cosine signals</li> </ul>
Analog input signal level	<ul style="list-style-type: none"> <li>• Offset voltage: 2.2 V – 2.8 V</li> <li>• Differential, 1 V peak to peak</li> </ul>
Input resistance	Differential 120 $\Omega$
Maximum analog signal frequency	$f_{\text{MAX}} : 250\text{ kHz}$
Interpolation multipliers	Programmable: x4 to x4096
Maximum “counts” frequency	80 mega-counts/sec “internally”
Automatic errors correction	<ul style="list-style-type: none"> <li>• Signal amplitudes mismatch</li> <li>• Signal phase shift</li> <li>• Signal offsets</li> </ul>
Encoder outputs	See Auxiliary Encoder Outputs specifications (4.6.3)

#### 4.6.2.4. Resolver

Feature	Details
Resolver format	<ul style="list-style-type: none"> <li>• Sine/Cosine</li> <li>• Differential</li> </ul>
Input resistance	Differential 2.49 k $\Omega$
Resolution	Programmable: 10 to 15 bits
Maximum electrical frequency (RPS)	512 revolutions/sec
Resolver transfer ratio	0.5
Reference frequency	1/Ts (Ts = sample time in seconds)
Reference voltage	Supplied by the Solo Guitar
Reference current	up to $\pm 50$ mA
Encoder outputs	See Auxiliary Encoder Output specifications (4.6.3)

#### 4.6.2.5. Tachometer\*

Feature	Details
Tachometer format	Differential
Maximum operating differential voltage for TAC1+, TAC1-	$\pm 20$ V
Maximum absolute differential input voltage for TAC1+, TAC1-	$\pm 25$ V
Maximum operating differential voltage for TAC2+, TAC2-	$\pm 50$ V
Maximum absolute differential input voltage for TAC2+, TAC2-	$\pm 60$ V
Input resistance for TAC1+, TAC1-	46 k $\Omega$
Input resistance for TAC2+, TAC2-	100 k $\Omega$
Resolution	14 bit

\* **Note:** Only one Tachometer port can be used at a time (either TAC1+/TAC1- or TAC2+/TAC2-).  
TAC1+/TAC1- is used in applications with having a Tachometer of less than 20 V.  
TAC2+/TAC2- is used in applications with having a Tachometer of between 20 V and 50 V.



#### 4.6.2.6. Potentiometer

Feature	Details
Potentiometer Format	Single-ended
Operating Voltage Range	0 to 5 V supplied by the Solo Guitar
Potentiometer Resistance	100 $\Omega$ to 1 k $\Omega$ ... above this range, linearity is affected detrimentally
Input Resistance	100 k $\Omega$
Resolution	14 bit

#### 4.6.3. Main Encoder Buffered Output

Feature	Details
Main encoder buffered output	<ul style="list-style-type: none"> <li>• A, B, Index</li> <li>• Differential outputs</li> <li>• Quadrature</li> </ul>
Interface	RS-422
Output current capability	Driving differential loads of 200 $\Omega$ on INDEX/INDEX-, CHB/CHB- and CHA/CHA- pairs
Available as options	Simultaneous buffered outputs of main-incremental encoder input
Maximum frequency	$f_{MAX}$ : 5 MHz pulses/output
Index (marker)	Length of pulse is one quadrature (one quarter of an encoder cycle) and synchronized to A&B

#### 4.6.4. Auxiliary Feedback Port (output mode YA[4]= 4)

Feature	Details
Emulated output	<ul style="list-style-type: none"> <li>• A, B, Index</li> <li>• Differential</li> </ul>
Output current capability	<ul style="list-style-type: none"> <li>• Maximum output current: <math>I_{OH} (\text{max}) = 2 \text{ mA}</math></li> <li>• High level output voltage: <math>V_{OH} &gt; 3.0 \text{ V}</math></li> <li>• Minimum output current: <math>I_{OL} = 2 \text{ mA}</math></li> <li>• Low level output voltage: <math>V_{OL} &lt; 0.4 \text{ V}</math></li> </ul>
Available as options	<ul style="list-style-type: none"> <li>• Emulated encoder outputs of analog encoder</li> <li>• Emulated encoder outputs of the resolver</li> <li>• Emulated encoder outputs of the tachometer</li> <li>• Emulated encoder outputs of the potentiometer</li> </ul>
Maximum frequency	$f_{MAX}$ : 5 MHz pulses/output
Edge separation between A & B	Programmable number of clocks to allow adequate noise filtering at remote receiver of emulated encoder signals
Index (marker)	Length of pulse is one quadrature (one quarter of an encoder cycle) and synchronized to A&B

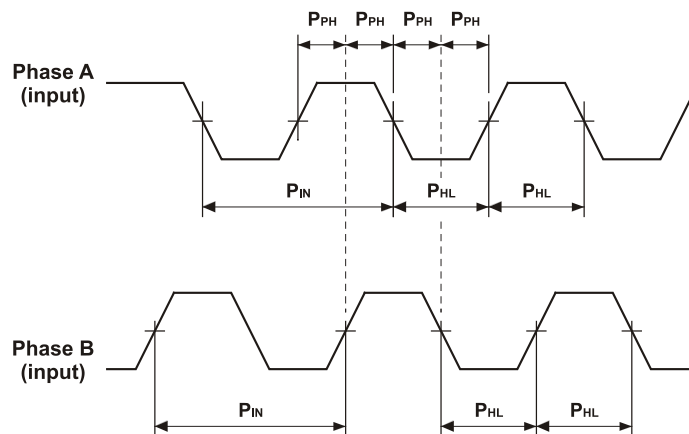
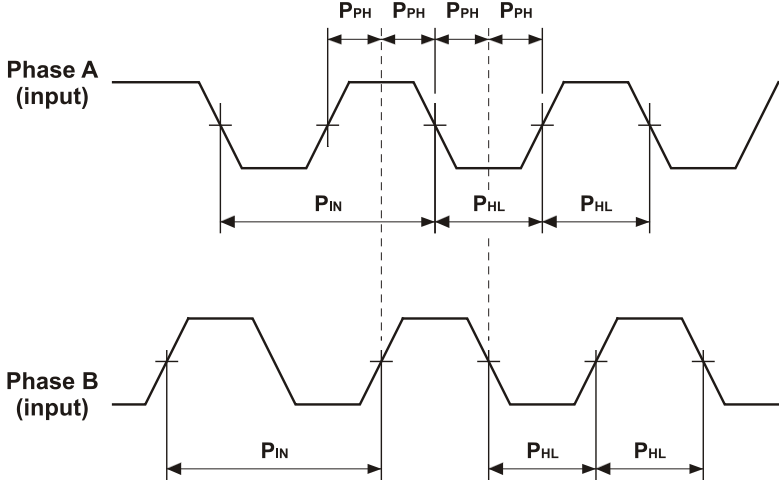


Figure 27: Auxiliary Feedback - Encoder Phase Diagram

#### 4.6.5. Auxiliary Feedback Port (input mode YA[4]= 2, 0)

Feature	Details
Encoder input, pulse and direction input	<ul style="list-style-type: none"> <li>• A, B, Index</li> <li>• Differential</li> </ul>
Input voltage	$V_{in}$ Low: $0\text{ V} < V_{IL} < 0.8\text{ V}$ $V_{in}$ High: $2\text{ V} < V_{IH} < 5\text{ V}$ Maximum absolute voltage: $0 < V_{in} < 5.5\text{ V}$ Input current: $\pm 1\ \mu\text{A}$
Available as options	<ul style="list-style-type: none"> <li>• Differential Buffered Encoder inputs</li> <li>• Differential Buffered Pulse and Direction inputs</li> </ul>
Edge separation between A & B	Programmable number of clocks to allow adequate noise filtering at remote receiver of emulated encoder signals
Index (marker)	Length of pulse is one quadrature (one quarter of an encoder cycle) and synchronized to A&B
 <p><b>Figure 28: Auxiliary Feedback - Encoder Phase Diagram</b></p>	

## 4.7. I/Os

The Solo Guitar has:

- 5 Digital Inputs
- 4 Digital Outputs
- 1 Analog Input

### 4.7.1. Digital Input Interfaces

Feature	Details
Type of input	Optically isolated
Input current for all inputs	Rin=3.43K, Iin = 1.2 mA @ Vin = 5 V Rin=3.43K, Iin = 6.7 mA @ Vin = 24 V
High-level input voltage	5 V < Vin < 24 V
Low-level input voltage	0 V < Vin < 1 V
Minimum pulse width	> 4 x TS, where TS is sampling time
Execution time (all inputs): the time from application of voltage on input until execution is complete	If input is set to one of the built-in functions — Home, Inhibit, Hard Stop, Soft Stop, Hard and Soft Stop, Forward Limit, Reverse Limit or Begin — execution is immediate upon detection: 0<T<4xTS If input is set to General input, execution depends on program. Typical execution time: ≈ 0.5 msec.
High-speed inputs – 5 & 6 minimum pulse width, in high-speed mode	T < 5 μsec <b>Notes:</b> <ul style="list-style-type: none"> <li>• Home mode is high-speed mode and can be used for fast capture and precise homing.</li> <li>• High speed input has a digital filter set to same value as digital filter (EF) of main encoder.</li> <li>• Highest speed is achieved when turning on optocouplers.</li> </ul>

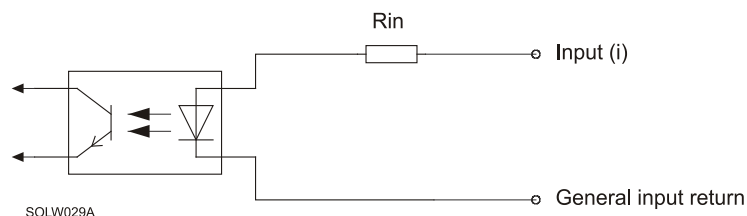


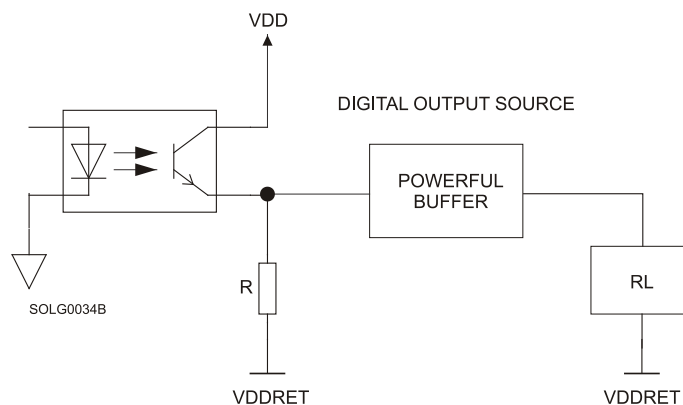
Figure 29: Digital Input Schematic

### 4.7.2. Powerful Digital Output Interface

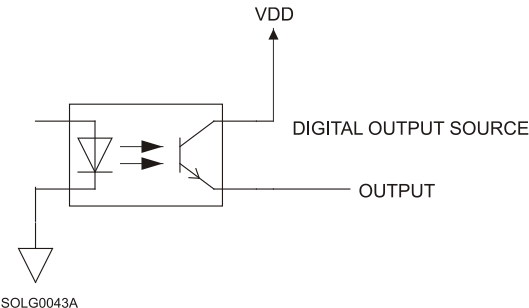
Feature	Details
Type of output	<ul style="list-style-type: none"> <li>• Optically isolated</li> <li>• Powerful Source capability</li> </ul>
VDD Supply Range	15 V to 30 V
Max. output current I <sub>out</sub> (max)	I <sub>out1</sub> (max) ≤ 500 mA I <sub>out2, 3, 4</sub> (max) ≤ 250 mA
VOH	$VDD \geq VOH \geq VDD - (I \times 0.15)$
VOL	$VOL \leq 1\text{ V}$
RL	External RL must be selected to limit output current. $RL = \frac{VDD - I \times 0.15}{I_{out\ (max)}}$
Executable time	If output is set to one of the built-in functions - Home flag, Brake or AOK - execution is immediate upon detection: $0 < T < 4 \times TS$ If output is set to General output and is executed from a program, the typical time is approximately 0.5 msec.

#### Schematic Diagram

##### SOURCE



### 4.7.3. Opto Digital Output Interface

Feature	Details
Type of output	<ul style="list-style-type: none"> <li>• Optically isolated</li> <li>• Open emitter</li> </ul>
VDD Supply Range	2.5 V to 30 V
Max. output current $I_{out (max)}$	$I_{out (max)} \leq 8 \text{ mA}$
VOL	$VOL \leq 0.3 \text{ V}$
RL	External RL must be selected to limit output current.  $RL = \frac{VDD - VOL}{I_{out (max)}}$
Executable time	If output is set to one of the built-in functions - Home flag, Brake or AOK - execution is immediate upon detection: $0 < T < 4 \times TS$  If output is set to General output and is executed from a program, the typical time is approximately 0.5 msec.
Schematic Diagram	
<p><b>SOURCE</b></p>  <p style="text-align: center;">SOLG0043A</p>	

#### 4.7.4. Brake

The brake can be controlled by Digital Output 1.

Digital Output 1 should be set to Brake.

Feature	Details
Rated voltage	24 V +10%
Rated current	0.5 A
Input power	12 W

#### 4.7.5. Analog Input

Feature	Details
Maximum operating differential voltage	$\pm 10$ V
Maximum absolute differential input voltage	$\pm 16$ V
Differential input resistance	3.74 k $\Omega$
Analog input command resolution	14-bit

### 4.8. Communications

Specification	Details
RS-232	<p><b>Signals:</b></p> <ul style="list-style-type: none"> <li>• RxD , TxD , Gnd</li> <li>• Full duplex, serial communication for setup and control.</li> <li>• Baud Rate of 9,600 to 57,600 bit/sec.</li> </ul>
CAN	<p><b>CAN bus Signals:</b></p> <ul style="list-style-type: none"> <li>• CAN_H, CAN_L, CAN_GND</li> <li>• Maximum Baud Rate of 1 Mbit/sec.</li> </ul> <p><b>Version:</b></p> <ul style="list-style-type: none"> <li>• DS 301 V4.01</li> </ul> <p><b>Layer Setting Service and Protocol Support:</b></p> <ul style="list-style-type: none"> <li>• DS 305</li> </ul> <p><b>Device Profile</b> (drive and motion control):</p> <ul style="list-style-type: none"> <li>• DS 402</li> </ul>

## 4.9. Pulse-Width Modulation (PWM)

Feature	Details
PWM resolution	12-bit
PWM switching frequency on the load	2/Ts (factory default 22 kHz on the motor)

## 4.10. Compliance with Standards

Specification	Details
<b>Quality Assurance</b>	
ISO 9001:2008	Quality Management
<b>Design</b>	
Approved IEC/EN 61800-5-1, Safety	Printed wiring for electronic equipment (clearance, creepage, spacing, conductors sizing, etc.)
MIL-HDBK- 217F	Reliability prediction of electronic equipment (rating, de-rating, stress, etc.)
<ul style="list-style-type: none"> <li>• UL 60950</li> <li>• IPC-D-275</li> <li>• IPC-SM-782</li> <li>• IPC-CM-770</li> <li>• UL 508C</li> <li>• UL 840</li> </ul>	Printed wiring for electronic equipment (clearance, creepage, spacing, conductors sizing, etc.)
In compliance with VDE0160-7 (IEC 68)	Type testing
<b>Safety</b>	
Recognized UL 508C	Power Conversion Equipment
In compliance with UL 840	Insulation Coordination Including Clearances and Creepage Distances for Electrical Equipment
In compliance with UL 60950	Safety of Information Technology Equipment Including Electrical Business Equipment
Approved IEC/EN 61800-5-1, Safety	Adjustable speed electrical power drive systems
In compliance with EN 60204-1	Low Voltage Directive 73/23/EEC





Specification	Details
<b>EMC</b>	
Approved <b>IEC/EN 61800-3, EMC</b>	Adjustable speed electrical power drive systems
In compliance with <b>EN 55011</b> Class A with <b>EN 61000-6-2</b> : Immunity for industrial environment, according to: <b>IEC 61000-4-2</b> / criteria B <b>IEC 61000-4-3</b> / criteria A <b>IEC 61000-4-4</b> / criteria B <b>IEC 61000-4-5</b> / criteria B <b>IEC 61000-4-6</b> / criteria A <b>IEC 61000-4-8</b> / criteria A <b>IEC 61000-4-11</b> / criteria B/C	Electromagnetic compatibility (EMC)
<b>Workmanship</b>	
In compliance with <b>IPC-A-610</b> , level 3	Acceptability of electronic assemblies
<b>PCB</b>	
In compliance with <b>IPC-A-600</b> , level 2	Acceptability of printed circuit boards
<b>Packing</b>	
In compliance with <b>EN 100015</b>	Protection of electrostatic sensitive devices
<b>Environmental</b>	
In compliance with <b>2002/96/EC</b>	Waste Electrical and Electronic Equipment regulations (WEEE) <b>Note:</b> Out-of-service Elmo drives should be sent to the nearest Elmo sales office.
In compliance with <b>2002/95/EC</b> (effective July 2006)	Restrictions on Application of Hazardous Substances in Electric and Electronic Equipment (RoHS)