

Gold Guitar Digital Servo Drive Installation Guide



Notice

This guide is delivered subject to the following conditions and restrictions:

- This guide contains proprietary information belonging to Elmo Motion Control Ltd. Such information is supplied solely for the purpose of assisting users of the Gold Guitar servo drive in its installation.
- The text and graphics included in this manual are for the purpose of illustration and reference only. The specifications on which they are based are subject to change without notice.
- Information in this document is subject to change without notice.

Document no. MAN-G-GUTIG (Ver. 1.105)

Copyright © 2017

Elmo Motion Control Ltd.

All rights reserved.

Catalog Number

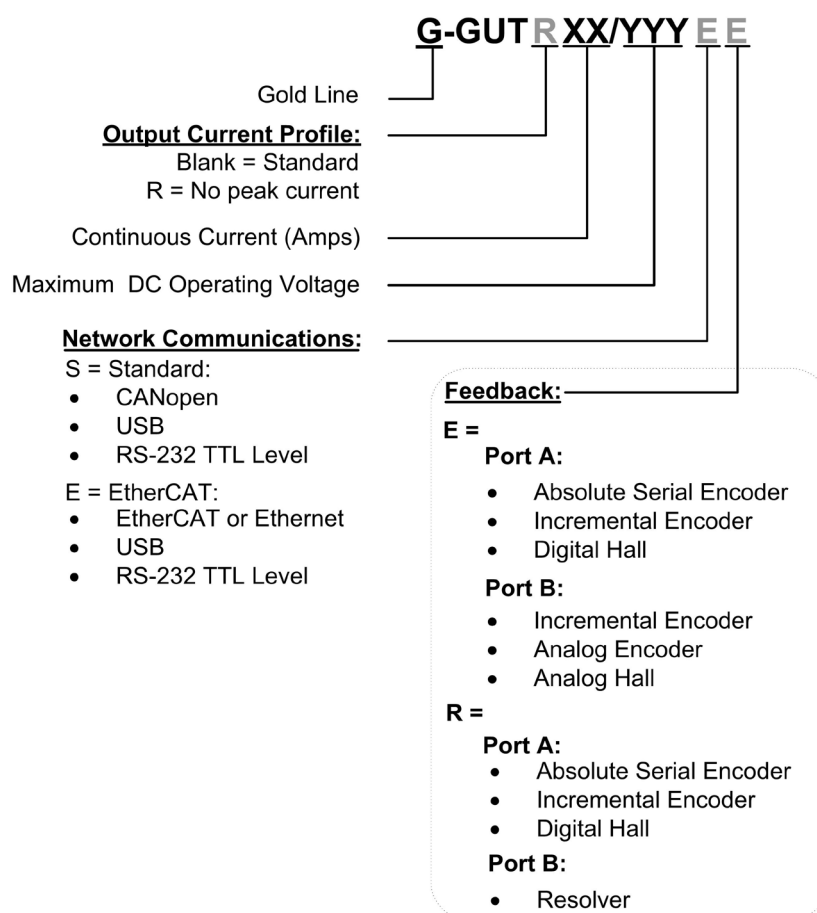



- Chapter 1: This Installation Guide5**

- Chapter 2: Safety Information5**
 - 2.1. Warnings 6
 - 2.2. Cautions..... 6
 - 2.3. CE Marking Conformance..... 6
 - 2.4. Warranty Information 6

- Chapter 3: Product Description.....7**

- Chapter 4: Technical Information.....8**
 - 4.1. Physical Specifications..... 8
 - 4.2. Technical Data 8
 - 4.2.1. Control Supply 9
 - 4.2.2. Product Features 9
 - 4.2.3. Environmental Conditions 10
 - 4.2.4. Gold Line Standards..... 11

- Chapter 5: Installation.....12**
 - 5.1. Unpacking the Drive Components 12

- Chapter 6: Mounting the Gold Guitar.....13**

- Chapter 7: Integrating the Gold Guitar on a PCB.....14**
 - 7.1. Power Returns (PR) 14
 - 7.2. COMRET..... 14
 - 7.3. Earth Connection (PE) 14
 - 7.4. Power Return (PR), Common Return (COMRET) and Earth Connections (PE)..... 15
 - 7.5. Power Conductors PCB layout..... 16

- Chapter 8: The Gold Guitar Connection Diagram17**

- Chapter 9: PCB Connections18**
 - 9.1. Wiring legend 18
 - 9.2. Connector Types..... 20
 - 9.3. Drive Status Indicator 20
 - 9.4. Motor Power Connector Pinouts 21
 - 9.5. Main Power and Control Connector 23
 - 9.5.1. Main Power 23
 - 9.5.2. Control Supply 24
 - 9.5.3. Single Supply..... 25
 - 9.5.4. Separate Control Supply..... 26
 - 9.5.5. Shared Supply 27



- 9.6. Connector J2 - Feedback, Analog Inputs, RS-232, USB, EtherCAT, Ethernet, and CAN 28
 - 9.6.1. Feedback Port A..... 31
 - 9.6.1.1. Incremental Encoder 31
 - 9.6.1.2. Hall Sensors 32
 - 9.6.1.3. Absolute Serial Encoder..... 33
 - 9.6.1.4. Hiperface 35
 - 9.6.2. Feedback Port B..... 36
 - 9.6.2.1. Incremental Encoder 36
 - 9.6.2.2. Interpolated Analog (Sine/Cosine) Encoder 37
 - 9.6.2.3. Resolver 38
 - 9.6.3. Port C – Emulated Encoder Output 39
 - 9.6.4. Analog Inputs..... 40
 - 9.6.4.1. Analog Input 1 40
 - 9.6.4.2. Analog Input 2 41
 - 9.6.5. RS232 TTL Logic Level 42
 - 9.6.6. USB 2.0 43
 - 9.6.7. EtherCAT/Ethernet 44
 - 9.6.8. CAN 45
- 9.7. Connector J1 - Digital I/O, Analog Inputs, LEDs and STO 46
 - 9.7.1. Digital Inputs..... 48
 - 9.7.1.1. TTL voltage level 48
 - 9.7.2. Digital Outputs..... 49
 - 9.7.2.1. Isolated Open Collector and Open Emitter 49
 - 9.7.3. Analog Inputs..... 49
 - 9.7.4. STO Input Interfaces - TTL Mode 50
 - 9.7.5. EtherCAT Status Indicator 50
- Chapter 10: Powering Up 51**
 - 10.1. Initializing the System 51
- Chapter 11: Heat Dissipation 52**
 - 11.1. Thermal Data 52
 - 11.2. Heat Dissipation Data 52
 - 11.3. How to Use the Charts 53
- Chapter 12: Dimensions 54**



Chapter 1: This Installation Guide

This installation Guide details the technical data, pinouts, and power connectivity of the Gold Guitar. For a comprehensive detailed description of the functions and connections of the Board Level Module (BLM) drive, refer to the MAN-G-Board Level Modules Hardware Manual.

Chapter 2: Safety Information

In order to achieve the optimum, safe operation of the Gold Guitar, it is imperative that you implement the safety procedures included in this installation guide. This information is provided to protect you and to keep your work area safe when operating the Gold Guitar and accompanying equipment.

Please read this chapter carefully before you begin the installation process.

Before you start, ensure that all system components are connected to earth ground. Electrical safety is provided through a low-resistance earth connection.

Only qualified personnel may install, adjust, maintain and repair the servo drive. A qualified person has the knowledge and authorization to perform tasks such as transporting, assembling, installing, commissioning and operating motors.

The Gold Guitar contains electrostatic-sensitive components that can be damaged if handled incorrectly. To prevent any electrostatic damage, avoid contact with highly insulating materials, such as plastic film and synthetic fabrics. Place the product on a conductive surface and ground yourself in order to discharge any possible static electricity build-up.

To avoid any potential hazards that may cause severe personal injury or damage to the product during operation, keep all covers and cabinet doors shut.

The following safety symbols are used in this and all Elmo Motion Control manuals:



Warning:

This information is needed to avoid a safety hazard, which might cause bodily injury or death as a result of incorrect operation.



Caution:

This information is necessary to prevent bodily injury, damage to the product or to other equipment.



Important:

Identifies information that is critical for successful application and understanding of the product.



2.1. Warnings

- To avoid electric arcing and hazards to personnel and electrical contacts, never connect/disconnect the servo drive while the power source is on.
- Power cables can carry a high voltage, even when the motor is not in motion. Disconnect the Gold Guitar from all voltage sources before servicing.
- The high voltage products within the Gold Line range contain grounding conduits for electric current protection. Any disruption to these conduits may cause the instrument to become hot (live) and dangerous.
- After shutting off the power and removing the power source from your equipment, wait at least 1 minute before touching or disconnecting parts of the equipment that are normally loaded with electrical charges (such as capacitors or contacts). Measuring the electrical contact points with a meter, before touching the equipment, is recommended.



2.2. Cautions

- The maximum DC power supply connected to the instrument must comply with the parameters outlined in this guide.
- When connecting the Gold Guitar to an approved isolated control power supply, connect it through a line that is separated from hazardous live voltages using reinforced or double insulation in accordance with approved safety standards.
- Before switching on the Gold Guitar, verify that all safety precautions have been observed and that the installation procedures in this manual have been followed.
- Make sure that the Safe Torque Off is operational

2.3. CE Marking Conformance

The Gold Guitar is intended for incorporation in a machine or end product. The actual end product must comply with all safety aspects of the relevant requirements of the European Safety of Machinery Directive 2006/42/EC as amended, and with those of the most recent versions of standards EN 60204-1 and EN ISO 12100 at the least, and in accordance with 2006/95/EC.

Concerning electrical equipment designed for use within certain voltage limits, the Gold Guitar meets the provisions outlined in 2006/95/EC. The party responsible for ensuring that the equipment meets the limits required by EMC regulations is the manufacturer of the end product.

2.4. Warranty Information

The products covered in this manual are warranted to be free of defects in material and workmanship and conform to the specifications stated either within this document or in the product catalog description. All Elmo drives are warranted for a period of 12 months from the date of shipment. No other warranties, expressed or implied — and including a warranty of merchantability and fitness for a particular purpose — extend beyond this warranty.



Chapter 3: Product Description

The Gold Guitar operates from a DC power source and delivers up to **4.1 kW of continuous power** or **8.2 kW of peak power** in a 38.0 cc (2.32 in³) package (55 x 46 x 15 mm or 2.2" x 1.8" x 0.6"). The Gold Guitar is designed to be mounted on a PCB by soldering its pins directly to the PCB.

This advanced, high power density servo drive provides top performance, advanced networking and built-in safety, as well as a fully featured motion controller and local intelligence. Power to the Gold Guitar is provided by a DC power source which is isolated from the Mains. The Gold Guitar can operate with single or dual power supplies. If separation between the main DC power source and a control supply is required, then a control supply (isolated from the Mains) is required.

The Gold Guitar can operate as a stand-alone device or as part of a multi-axis system in a distributed configuration on a real-time network.

The Gold Guitar drive is easily set up and tuned using the Elmo Application Studio (EASII) software tools. As part of the Gold product line, it is fully programmable with the Elmo motion control language. For more information about software tools refer to the Elmo Application Studio (EASII) User Guide.

The Gold Guitar is available in a variety of models. There are multiple power rating options, two different communications options, a number of feedback options and different I/O configuration possibilities.



Chapter 4: Technical Information

4.1. Physical Specifications

| Feature | Units | All Types |
|-----------------|---------|---------------------------------------|
| Weight | g (oz) | 178.75 g (6.31 oz) |
| Dimension | mm (in) | 80 x 61 x 31 mm (3.15" x 2.4" x 1.2") |
| Mounting method | | PCB mount |

4.2. Technical Data

| Feature | Units | | | | | | |
|---|-------|--------------------|--------|--------|---------------|--------|--------|
| | | 20/100 | 35/100 | 50/100 | 10/200 | 17/200 | 20/200 |
| Minimum supply voltage | VDC | 14 | | | 23 | | |
| Nominal supply voltage | VDC | 85 | | | 170 | | |
| Maximum supply voltage | VDC | 95 | | | 195 | | |
| Maximum continuous power output | W | 1600 | 2800 | 4000 | 1650 | 2800 | 3240 |
| Efficiency at rated power (at nominal conditions) | % | > 98 | | | | | |
| Maximum output voltage | VDC | 14 V to 96 V | | | 23 V to 195 V | | |
| Continuous current limit (I _c) amplitude of sinusoidal current, or DC trapezoidal commutation | A | 20 | 35 | 50 | 10 | 17 | 20 |
| Sinusoidal continuous RMS current limit (I _c) | A | 14.2 | 24.7 | 35.4 | 7.07 | 12 | 14.3 |
| Peak current limit | A | 2 x I _c | | | | | |

Table 1: Power Ratings

Note on current ratings: The current ratings of the Gold Guitar are given in units of DC amperes (ratings that are used for trapezoidal commutation or DC motors). The RMS (sinusoidal commutation) value is the DC value divided by 1.41.



4.2.1. Control Supply

| Feature | Details |
|------------------------------|--|
| Control supply | <i>Isolated DC source only</i> |
| Control supply input voltage | 14 to 95 VDC (100 V models) 23 to 195 (200 V models) |
| Control supply input power | ≤ 5 VA without external loading ≤ 8 VA with full external loading |

4.2.2. Product Features

| Main Feature | Details | Presence / No. |
|------------------------------|-----------------------------------|----------------|
| STO | TTL | √ |
| Digital Input Option | TTL | 6 |
| Digital Output Option | Open Collector-emitter (isolated) | 2 |
| | TTL 3.3V(Non Isolation) | 2 |
| Analog Input | Differential ±10V | 1 |
| | Single Ended | 1 |
| Feedback | Standard Port A, B, & C | √ |
| Communication Option | USB | √ |
| | EtherCAT | √ |
| | CAN | √ |
| | RS-232 TTL level | √ |



4.2.3. Environmental Conditions

You can guarantee the safe operation of the Gold Guitar by ensuring that it is installed in an appropriate environment.

| Feature | Details |
|---|---|
| Operating ambient temperature according to IEC60068-2-2 | 0 °C to 40 °C (32 °F to 104 °F) |
| Storage temperature | -20 °C to +85 °C (-4 °F to +185 °F) |
| Maximum non-condensing humidity according to IEC60068-2-78 | 95% |
| Maximum Operating Altitude | 2,000 m (6562 feet) It should be noted that servo drives capable of higher operating altitudes are available on request. |
| Mechanical Shock according to IEC60068-2-27 | 15g / 11ms Half Sine |
| Vibration according to IEC60068-2-6 | 5 Hz ≤ f ≤ 10 Hz: ±10mm 10 Hz ≤ f ≤ 57 Hz: 4G 57 Hz ≤ f ≤ 500 Hz:5G |



4.2.4. Gold Line Standards

The following table describes the Main Standards of the Gold Guitar servo drive. For further details refer to Chapter 17 in the MAN-G-Board Level Modules Hardware Manual.

| Main Standards | Item |
|---|---|
| The related standards below apply to the performance of the servo drives as stated in the environmental conditions in section 4.2.3 Environmental Conditions above. | |
| STO IEC 61800-5-2:2007 SIL 3 | Adjustable speed electrical power drive systems – Safety requirements – Functional |
| EN ISO 13849-1:2008 PL e, Cat 3 | Safety of machinery — Safety-related parts of control systems. |
| Approved IEC/EN 61800-5-1 | Adjustable speed electrical power drive systems Safety requirements – Electrical, thermal and energy |
| Recognized UL61800-5-1 | Adjustable speed electrical power drive systems Safety requirements – Electrical, thermal and energy |
| Recognized UL 508C | Power Conversion Equipment |
| In compliance with UL 840 | Insulation Coordination Including Clearances and Creepage Distances for Electrical Equipment |
| Conformity with CE 2006/95/EC | Low-voltage directive 2006/95/EC |
| Recognized CSA C22.2 NO. 14-13 | Industrial Control Equipment |



Chapter 5: Installation

The Gold Guitar must be installed in a suitable environment and properly connected to its voltage supplies and the motor.

5.1. Unpacking the Drive Components

Before you begin working with the Gold Guitar, verify that you have all of its components, as follows:

- The Gold Guitar servo drive
- The Elmo Application Studio (EAS) software and software manual

The Gold Guitar is shipped in a cardboard box with Styrofoam protection.

To unpack the Gold Guitar:

1. Carefully remove the servo drive from the box and the Styrofoam.
2. Check the drive to ensure that there is no visible damage to the instrument. If any damage has occurred, report it immediately to the carrier that delivered your drive.
3. To ensure that the Gold Guitar you have unpacked is the appropriate type for your requirements, locate the part number sticker on the side of the Gold Guitar. It looks like this:



4. Verify that the Gold Guitar type is the one that you ordered, and ensure that the voltage meets your specific requirements.

The part number at the top provides the type designation. Refer to the appropriate part number in the section Catalog Number at the beginning of the installation guide.



Chapter 6: Mounting the Gold Guitar

The Gold Guitar was designed for mounting on a printed circuit board (PCB) via 1.27 mm pitch 0.41 mm square pins and 2 mm pitch 0.51 mm square pins. When integrating the Gold Guitar into a device, be sure to leave about 1 cm (0.4") outward from the heat-sink to enable free air convection around the drive. We recommend that the Gold Guitar be soldered directly to the board. Alternatively, though this is not recommended, the Gold Guitar can be attached to socket connectors mounted on the PCB. If the PCB is enclosed in a metal chassis, we recommend that the Gold Guitar be screw-mounted to it as well to help with heat dissipation. The Gold Guitar has screw-mount holes on each corner of the heat-sink for this purpose – see below.

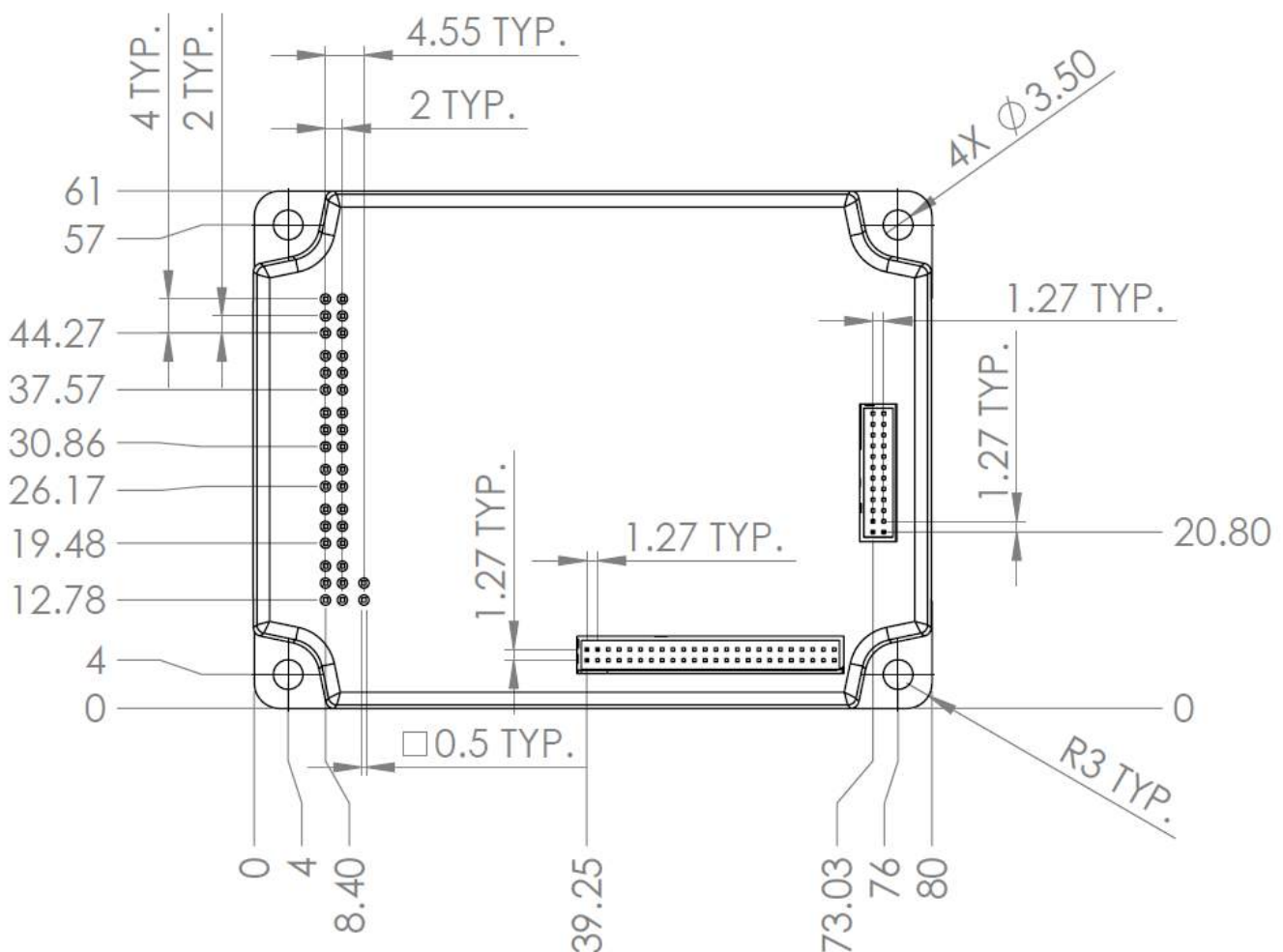

All measurements are in mm

Figure 1: Gold Guitar Dimensions



Chapter 7: Integrating the Gold Guitar on a PCB

The Gold Whistle is designed to be mounted on a PCB by soldering its pins directly to the PCB. Refer to Chapter 5 in the MAN-G-Board Level Modules Hardware Manual and the drawings in the Gold Line Whistle Design Guide MAN-G-WHIDG for further information.

7.1. Power Returns (PR)

In the Gold Guitar, the power stage and control stage are internally connected, and the negative node of the DC power bus is designates as PR

The maximum realistic Power Return is achieved using a plane, which connects between the Gold Drive and the power source. The impedance on this plane must be as low as possible to reduce the impedance between the “Grounds”. This effectively reduces the levels of common mode differences, interferences, EMI etc.

7.2. COMRET

For details of the COMRET, refer to the section 5.4 in the MAN-G-Board Level Modules Hardware Manual.

7.3. Earth Connection (PE)

The PE (Earth connection) terminal is connected internally in the drive to the Gold Guitar’s chassis (heat-sink + metal cover) which serves as an EMI common plane. Any other assembly metallic parts (such as the chassis) should also be connected to the PE.

Under normal operating conditions, the PE trace carries no current. The only time these traces carry current is under unusual conditions (such as when the device has become a potential shock or fire hazard while conducting external EMI interferences directly to ground). When connected properly the PE trace prevents these hazards from affecting the drive.



7.4. Power Return (PR), Common Return (COMRET) and Earth Connections (PE)

Safety regulations (UL61800-5-1, IEC61800-5-1, and UL508C) require that the servo drive, as a “stand alone”, must withstand breakdown voltages of 2KV for the 200V models, and 1.7KV for the 100V models, between PE to PR. However, the connections between PE to PR and the COMRET are essential for the safe operation of the servo drive. Therefore the following topology must be used:

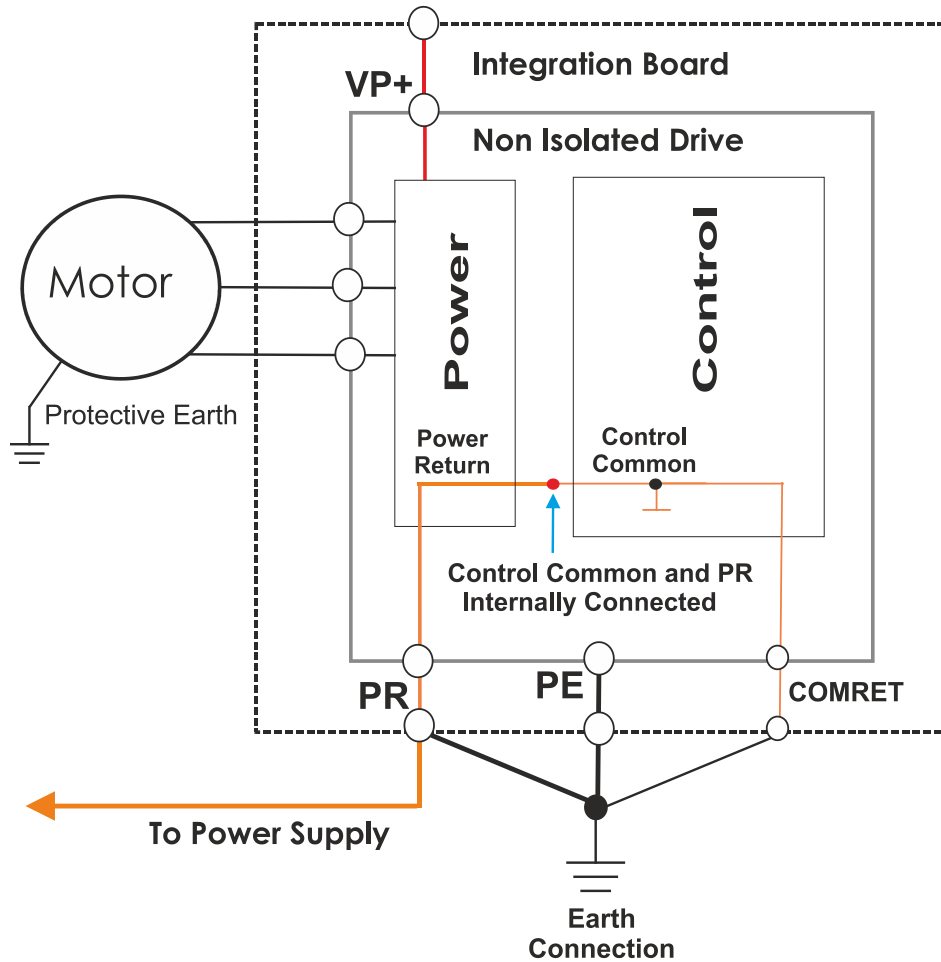

Figure 2: Gold Guitar Earth Connections

The connections to PE are essential, but must be done externally to the integration board.



7.5. Power Conductors PCB layout

The PCB virtually divided into two zones; Power Zone, and Control & Communication Zone.

- **Power Zone**
This area is dedicated to Power conductors only: VP+, PR, PE, VL+, VL-, VN- and motor leads.
- **Control and Communication Zone**
This area of the PCB is dedicated to Control low level signals

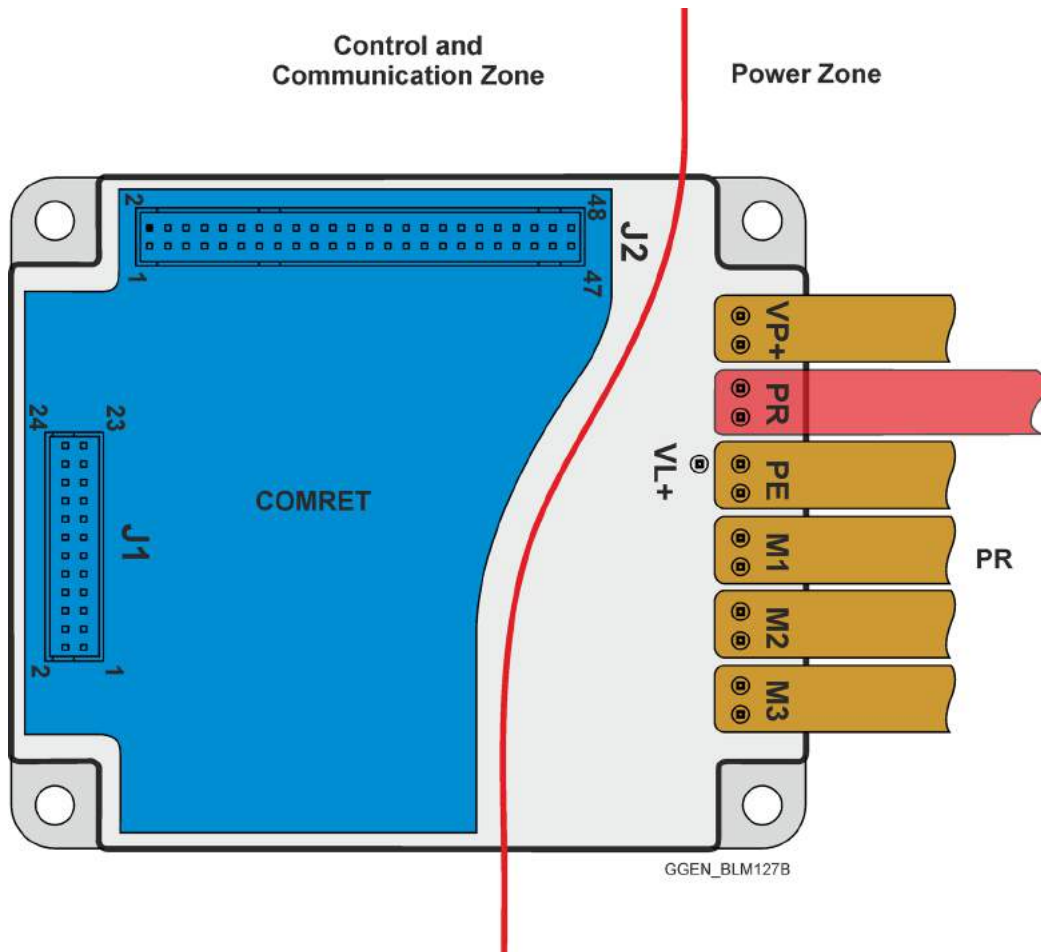

Figure 3: Gold Guitar Power Conductors PCB layout

For more details, refer to the section 5.4 in the MAN-G-Board Level Modules Hardware Manual.



Chapter 8: The Gold Guitar Connection Diagram

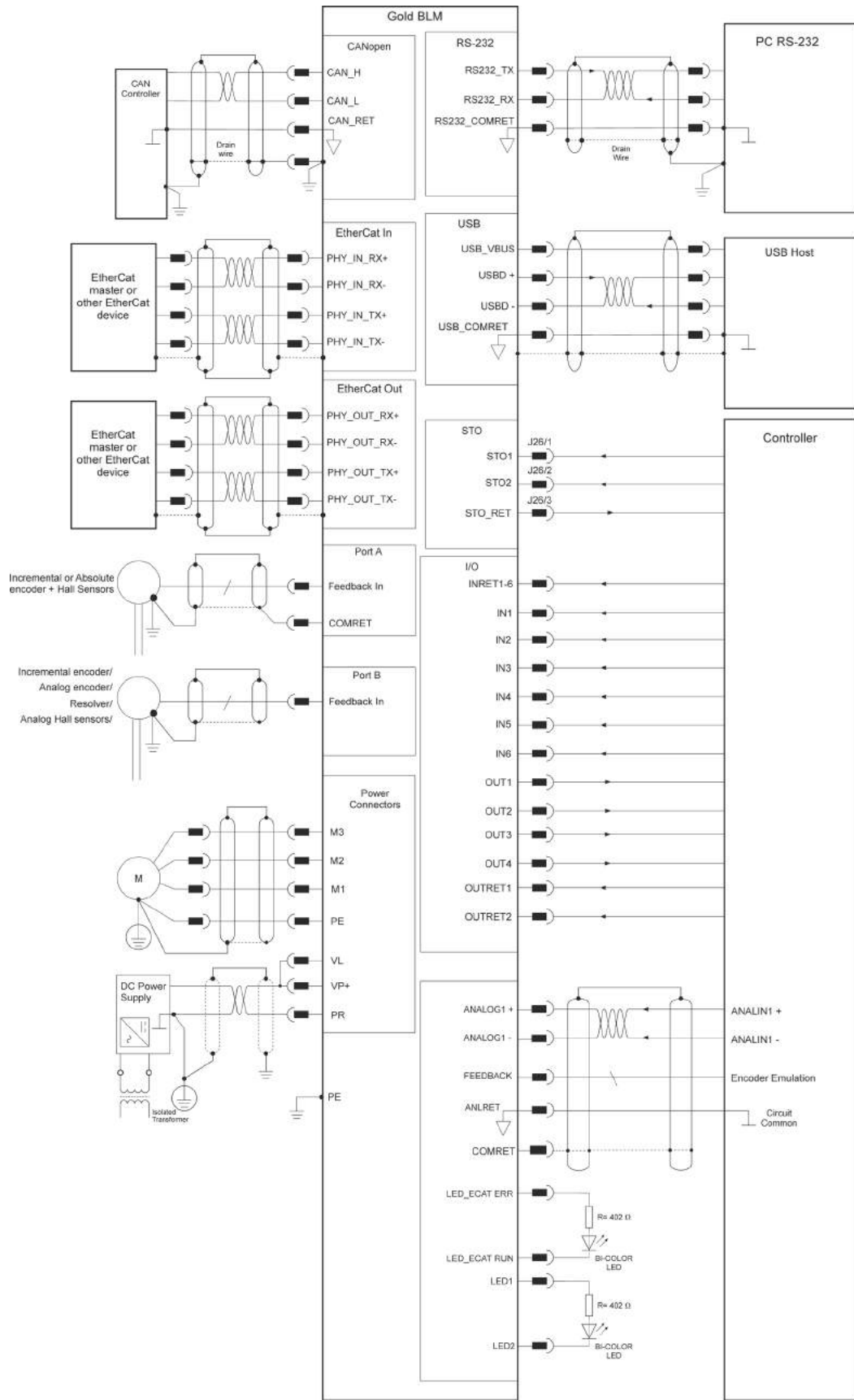



Figure 4: The Gold Guitar Connection Diagram



Chapter 9: PCB Connections

9.1. Wiring legend

The following table legend describes the wiring symbols detailed in all installation guides. All the wiring diagrams show wiring for D-TYPE connectors.

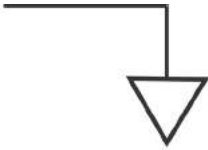
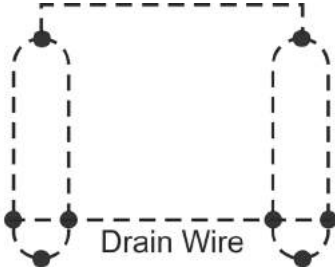
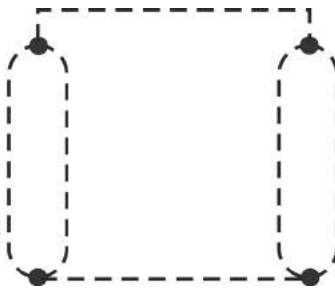
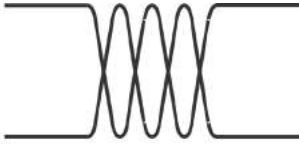
| Wiring Symbol | Description |
|--|--|
|  <p>GGEN_101D-A</p> | Earth connection (PE) |
|  <p>GGEN_101D-B</p> | Earth Connection |
|  <p>GGEN_101D-C</p> | Common at the Controller |
|  <p>GGEN_101D-D</p> | <p>Shielded cable with drain wire.</p> <p>The drain wire is a non-insulated wire that is in direct contact with the braid (shielding).</p> <p>Shielded cable with drain wire significantly simplifies the wiring and earthing.</p> |
|  <p>GGEN_101D-E</p> | Shielded cable braid only, without drain wire. |
|  <p>GGEN_101D-F</p> | Twisted-pair wires |

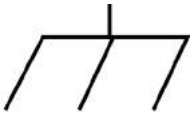
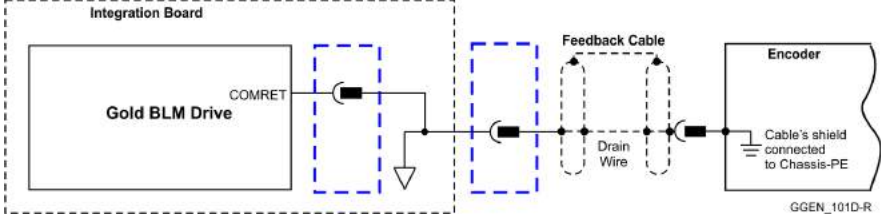

| Wiring Symbol | Description |
|--|--|
|  <p>GGEN_101D-K</p> | Analog Ground |
|  <p>Integration Board</p> <p>Gold BLM Drive</p> <p>COMRET</p> <p>Feedback Cable</p> <p>Encoder</p> <p>Drain Wire</p> <p>Cable's shield connected to Chassis-PE</p> <p>GGEN_101D-R</p> | <p>Encoder Earthing.</p> <p>The cable's shield is connected to the chassis (PE) in the connector.</p> <p>Earthing the Encoder and connecting the Earth (PE) to the drive COMRET is mandatory to insure reliable operation, high noise immunity and rejection of voltage common mode interferences.</p> |



9.2. Connector Types

The Gold Guitar has nine connectors.

| Port | Pins | Type | Function | Connector Location |
|------|------|-----------------------------|---|--------------------|
| J2 | 2x24 | 1.27 mm pitch 0.41 mm sq | Feedbacks, Digital Halls, Analog Inputs, Communications | |
| J1 | 2x12 | | I/O, LEDs, STO | |
| VL | 2x1 | 2 mm pitch 0.51 mm sq | Control power input | |
| VP+ | 2x3 | | Positive power input | |
| PR | 2x3 | | Power input return | |
| PE | 2x2 | | Protective earth | |
| M1 | 2x3 | | Motor power output 1 | |
| M2 | 2x3 | | Motor power output 2 | |
| M3 | 2x3 | | Motor power output 3 | |

Table 2: Connector Types

9.3. Drive Status Indicator

For details of the Drive Status Indicator wiring, refer to the Chapter 7 in the MAN-G-Board Level Modules Hardware Manual.



9.4. Motor Power Connector Pinouts

For full details see Chapter 8 in the MAN-G-Board Level Modules Hardware Manual.

| Pin | Function | Cable | | Pin Positions |
|--|------------------|-----------------|------------------|---------------|
| | | Brushless Motor | Brushed DC Motor | |
| PE | Protective earth | Motor | Motor | |
| M1 | Motor phase | Motor | N/C | |
| M2 | Motor phase | Motor | Motor | |
| M3 | Motor phase | Motor | Motor | |
| Connector Type: 2 mm pitch 0.51 mm sq. | | | | |

Table 3: Motor Connector

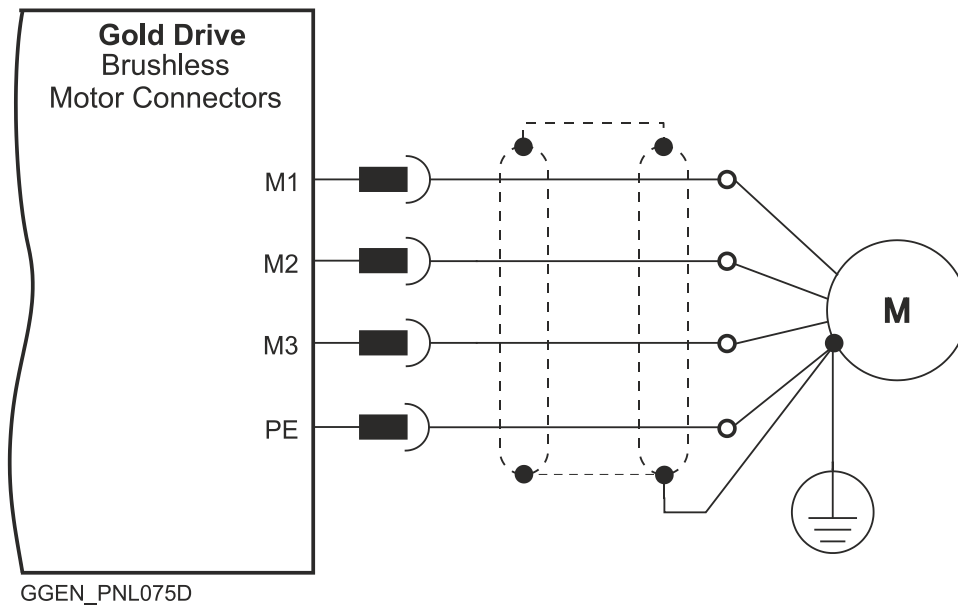

Figure 5: Brushless Motor Power Connection Diagram

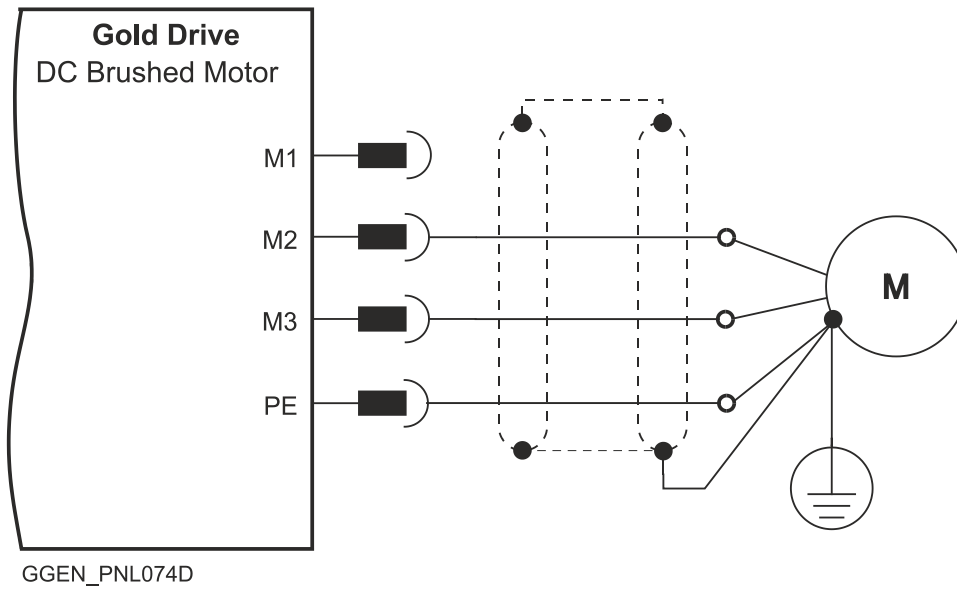

Figure 6: Brushed Motor Power Connection Diagram



9.5. Main Power and Control Connector

Note: There are multiple voltage ratings of the Gold Guitar (14 to 195 V). Make sure to use the correct power supply according to the maximum operating voltage of the Gold Guitar. Refer to Chapter 4: Technical Information for more details.

9.5.1. Main Power

| Pin | Function | Cable | Pin Positions |
|---------------------------------------|------------------|-------|---------------|
| VP+ | Pos. Power input | Power | |
| PR | Power return | Power | |
| PE | Protective earth | Power | |
| Connector Type: 2 mm pitch 0.51 mm sq | | | |

Note: The 12V to 195V DC power source must be from the Mains.

Connect the DC power cable to the VP+ and PR terminals on the Main Power Connector.

To connect your integration board to the DC power source:

1. The source of the VDC power supply must be isolated from the Mains.
2. For best immunity, it is highly recommended to use twisted and shielded cables for the DC power supply. A 3-wire shielded cable should be used. The gauge is determined by the actual current consumption of the motor.
3. Connect the cable shield to the closest earth connection near the power supply.
4. Connect the PE to the closest earth connection near the power supply.
5. Connect the PR to the closest earth connection near the power supply.
6. Before applying power, first verify the polarity of the connection.



9.5.2. Control Supply

Note:

The source of the Control Supply must be isolated from the Mains.

| Pin | Function | Pin Positions |
|---------------------------------------|-----------------------|--|
| VL | Control Supply Input |  GUI0018A |
| PR | Control Supply Return | |
| Connector Type: 2 mm pitch 0.51 mm sq | | |

Table 4: Control Supply Pins

Connect the VL+ and PR terminal to the control Connector.

To connect your integration board to the control supply:

1. The source of the control supply must be isolated from the Mains.
2. For safety reasons, connect the return (common) of the control supply source to the closest earth connection near the control supply source
3. Connect the cable shield to the closest earth connection near the control supply source
4. Before applying power, first verify the polarity of the connection.

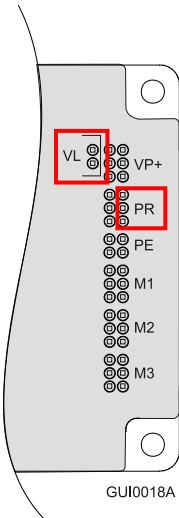

9.5.3. Single Supply

Only one power supply is required for the main and control power. The drawing below shows how a single supply is connected.

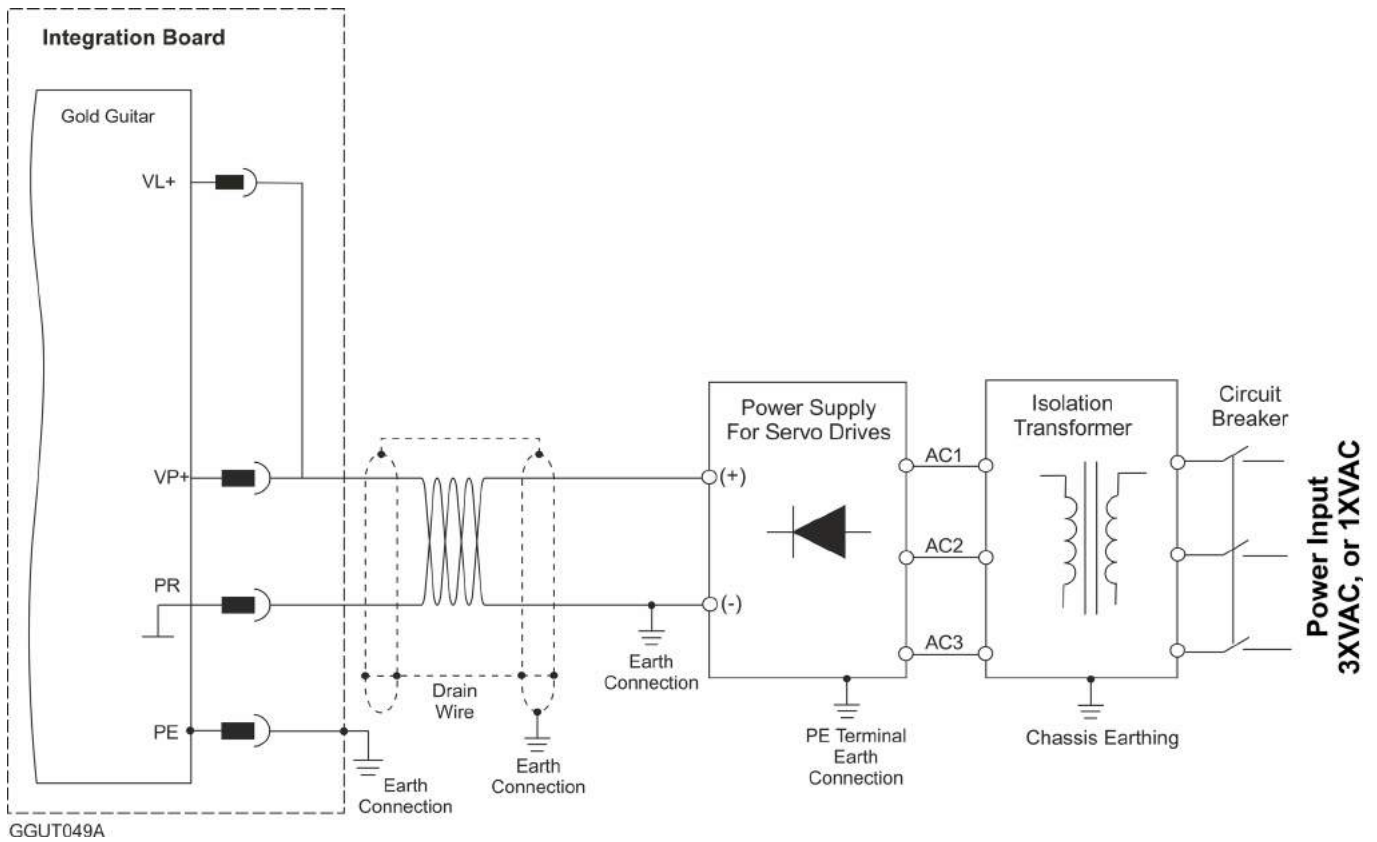

Figure 7: Single Power Supply Connection Diagram with VL+ Connected Internally

Note: Make sure to connect the PR to the closest earth connection near the power supply.



9.5.4. Separate Control Supply

Power to the Control Supply can be provided separately.

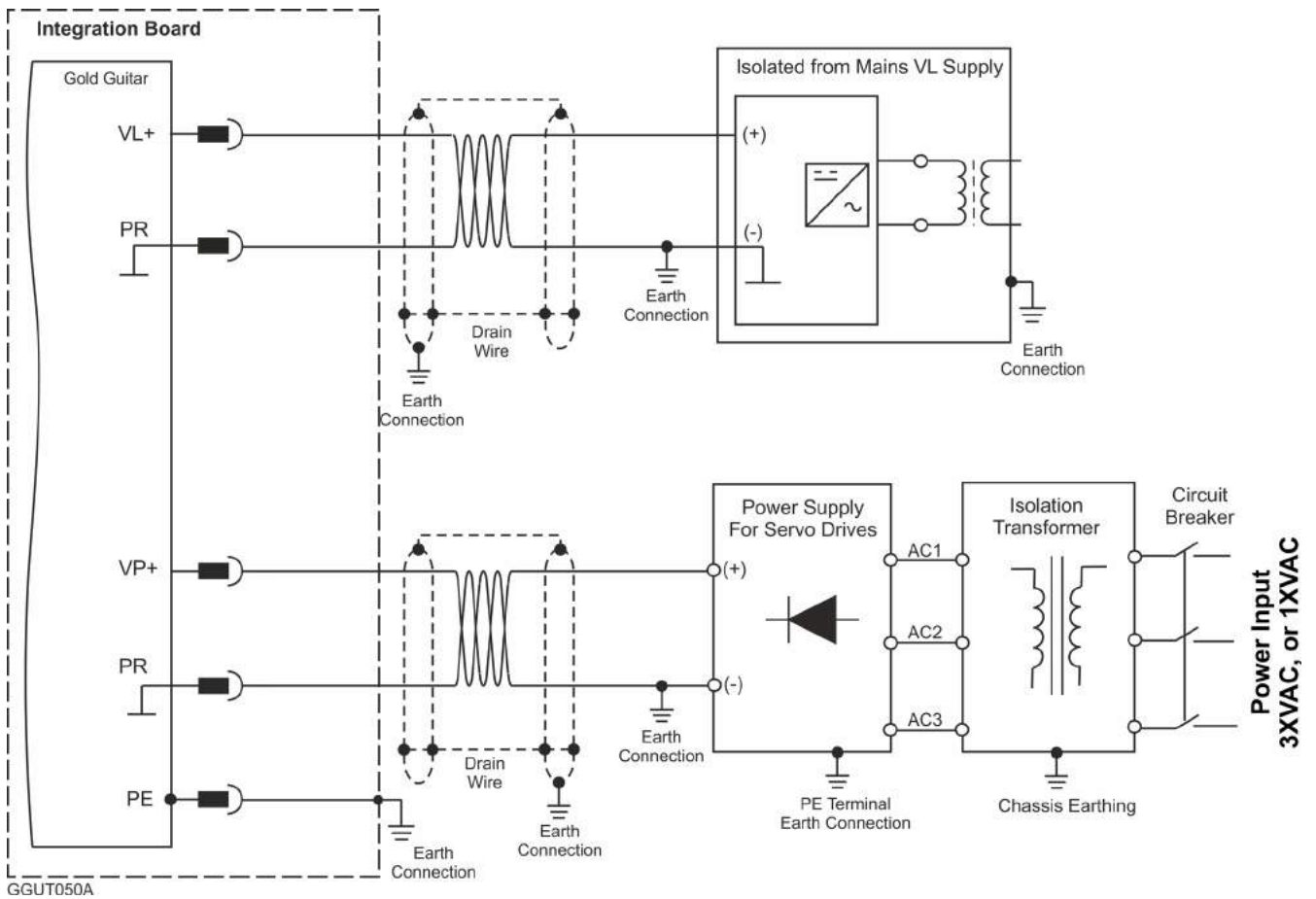

Figure 8: Separate Control Supply Connection Diagram

Note: Make sure to connect the PR to the closest earth connection near the power supply.



9.5.5. Shared Supply

A single DC Power Supply can supply the power for logic as well as the main power. If separation between the main DC power source and a control supply is required, then a control supply (isolated from the Mains) can be connected by implementing "diode coupling" (Figure 9).

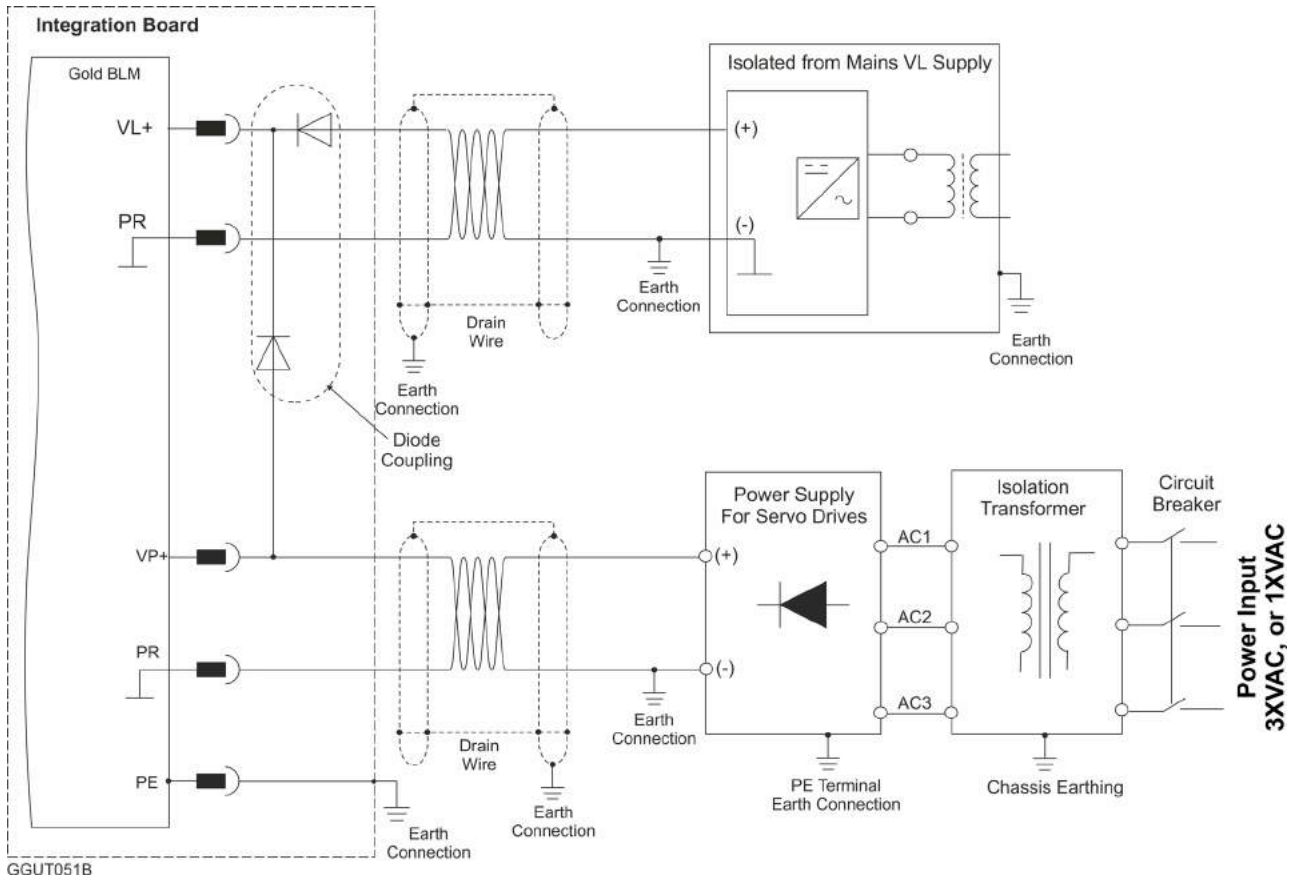
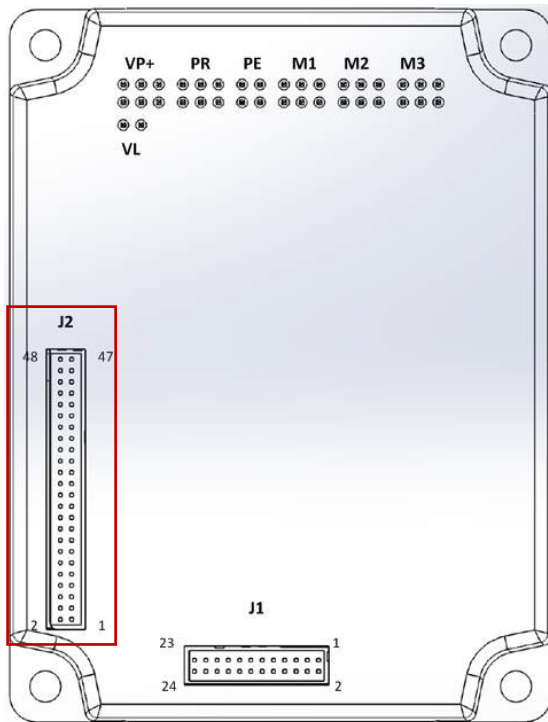

Figure 9: Shared Optional Power Supply Connection Diagram

Note: Make sure to connect the PR to the closest earth connection near the power supply.



9.6. Connector J2 - Feedback, Analog Inputs, RS-232, USB, EtherCAT, Ethernet, and CAN



Feedback A/B/C, Digital Halls – see Chapter 10: Feedbacks in the MAN-G-Board Level Modules Hardware Manual.

Analog Inputs - For full details on Analog Inputs, see Chapter 12 in the MAN-G-Board Level Modules Hardware Manual.

RS-232 – For full details on RS-232 see section 14.4 in the MAN-G-Board Level Modules Hardware Manual.

USB 2.0 – For full details on USB see section 14.1 in the MAN-G-Board Level Modules Hardware Manual.

EtherCAT/Ethernet – For full details on EtherCAT/Ethernet see section 14.2. in the MAN-G-Board Level Modules Hardware Manual.

CAN – For full details on CAN see section 14.3 in the MAN-G-Board Level Modules Hardware Manual.

Connector Type: 1.27 mm pitch 0.41 mm sq

Note regarding the EtherCAT and CAN communication options:
The J2 Connector exports all supported communication links. However, note that CAN and EtherCAT are not available in the same version of the Gold Guitar and are thus not operational simultaneously. See the part number diagram in Section 5.1 above for the different Gold Guitar configurations.

| Pin (J2) | Signal | Function |
|----------|------------------------|--|
| 1 | PortA_ENC_A+ /ABS_CLK+ | Port A- channel A/ Absolute encoder clock+ |
| 2 | PortC_ENCO_A- | Port C- channel A complement output |
| 3 | PortA_ENC_A-/ABS_CLK- | Port A- channel A complement / Absolute encoder clock- |
| 4 | PortC_ENCO_A+ | Port C- channel A output |
| 5 | PortA_ENC_B+/ABS_DATA+ | Port A - channel B/ Absolute encoder Data+ |
| 6 | PortC_ENCO_B- | Port C - channel B complement output |
| 7 | PortA_ENC_B-/ABS_DATA- | Port A - channel B complement / Absolute encoder Data- |
| 8 | PortC_ENCO_B+ | Port C - channel B output |



| Pin (J2) | Signal | Function |
|----------|--|---|
| 9 | PortA_ENC_INDEX+ | Port A – index |
| 10 | PortC_ENCO_INDEX- | Port C - index complement output |
| 11 | PortA_ENC_INDEX- | Port A - index complement |
| 12 | PortC_ENCO_INDEX+ | Port C - index output |
| 13 | PortB_ENC_A+/SIN+ | Port B - channel A/SIN+ |
| 14 | HC | Hall sensor C input |
| 15 | PortB_ENC_A-/SIN- | Port B - channel A complement/SIN- |
| 16 | HB | Hall sensor B input |
| 17 | PortB_ENC_B+/COS+ | Port B - channel B/COS+ |
| 18 | HA | Hall sensor A input |
| 19 | PortB_ENC_B-/COS- | Port B - channel B complement/COS- |
| 20 | ANARET | Analog return |
| 21 | PortB_ENC_INDEX+/ANALOG_I+ /RESOLVER_OUT+ | Port B - Channel_Index+ /Analog_Index+/Resolver_Out+ |
| 22 | ANALOG1+ | Analog input 1 |
| 23 | PortB_ENC_INDEX- /ANALOG_I-/RESOLVER_OUT- | Port B – Channel_Index /Analog_Index /Resolver_Out Compliments |
| 24 | ANALOG1- | Analog input 1 complement |
| 25 | COMRET | Common return |
| 26 | +3.3V | 3.3 V supply voltage for EtherCAT LEDs |
| 27 | PHY_IN_RX+ | EtherCAT In receive |
| 28 | EtherCAT: PHY_OUT_RX+ | EtherCAT Out receive |
| | CAN: Reserved | Reserved |
| 29 | PHY_IN_RX- | EtherCAT In receive complement |
| 30 | PHY_OUT_RX- | EtherCAT Out receive complement |
| 31 | COMRET | Common return |
| 32 | COMRET | Common return |
| 33 | PHY_IN_TX+ | EtherCAT In transmit |



| Pin (J2) | Signal | Function |
|----------|----------------------------|---|
| 34 | EtherCAT: PHY_OUT_TX+ | EtherCAT Out transmit |
| | CAN: Reserved | Reserved |
| 35 | PHY_IN_TX- | EtherCAT In transmit complement |
| 36 | EtherCAT: PHY_OUT_TX- | EtherCAT Out transmit complement |
| | CAN: Reserved | Reserved |
| 37 | PHY_IN_LINK_ACT | EtherCAT In active LED |
| 38 | EtherCAT: PHY_OUT_LINK_ACT | EtherCAT Out active LED |
| | CAN: CAN_L | CAN_L BUS Line(dominant low) |
| 39 | PHY_IN_SPEED | EtherCAT In Speed LED |
| 40 | EtherCAT: PHY_OUT_SPEED | EtherCAT Out Speed LED |
| | CAN: CAN_H | CAN_H BUS Line(dominant high) |
| 41 | USB D- | USB _N line |
| 42 | USB D+ | USB _P line |
| 43 | COMRET | Common return |
| 44 | USB_VBUS | USB VBUS 5V |
| 45 | RS232_RX /SB_OUT | There are two options for this pin: Option 1: RS232 receive (default) Option 2: Serial Bus output for extended I/O (refer to Chapter 13 of the MAN-G-Board Level Modules Hardware Manual) |
| 46 | COMRET | Common return |
| 47 | +5VE | Encoder +5 V supply |
| 48 | RS232_TX /SB_IN | There are two options for this pin: Option 1: RS232 transmit (Default) Option 2: Serial Bus IN for extended I/O (refer to Chapter 13 of the MAN-G-Board Level Modules Hardware Manual) |

Table 5: Connector J2 – Feedback and Analog Input



9.6.1. Feedback Port A

Port A supports the following sensor inputs:

- Digital Hall sensors
- Incremental encoder or absolute serial encoder, depending on the specific model
- Differential pulse-width modulation (PWM) signal input can be connected to port A
- Differential Pulse & Direction signal inputs can be connected to port A

9.6.1.1. Incremental Encoder

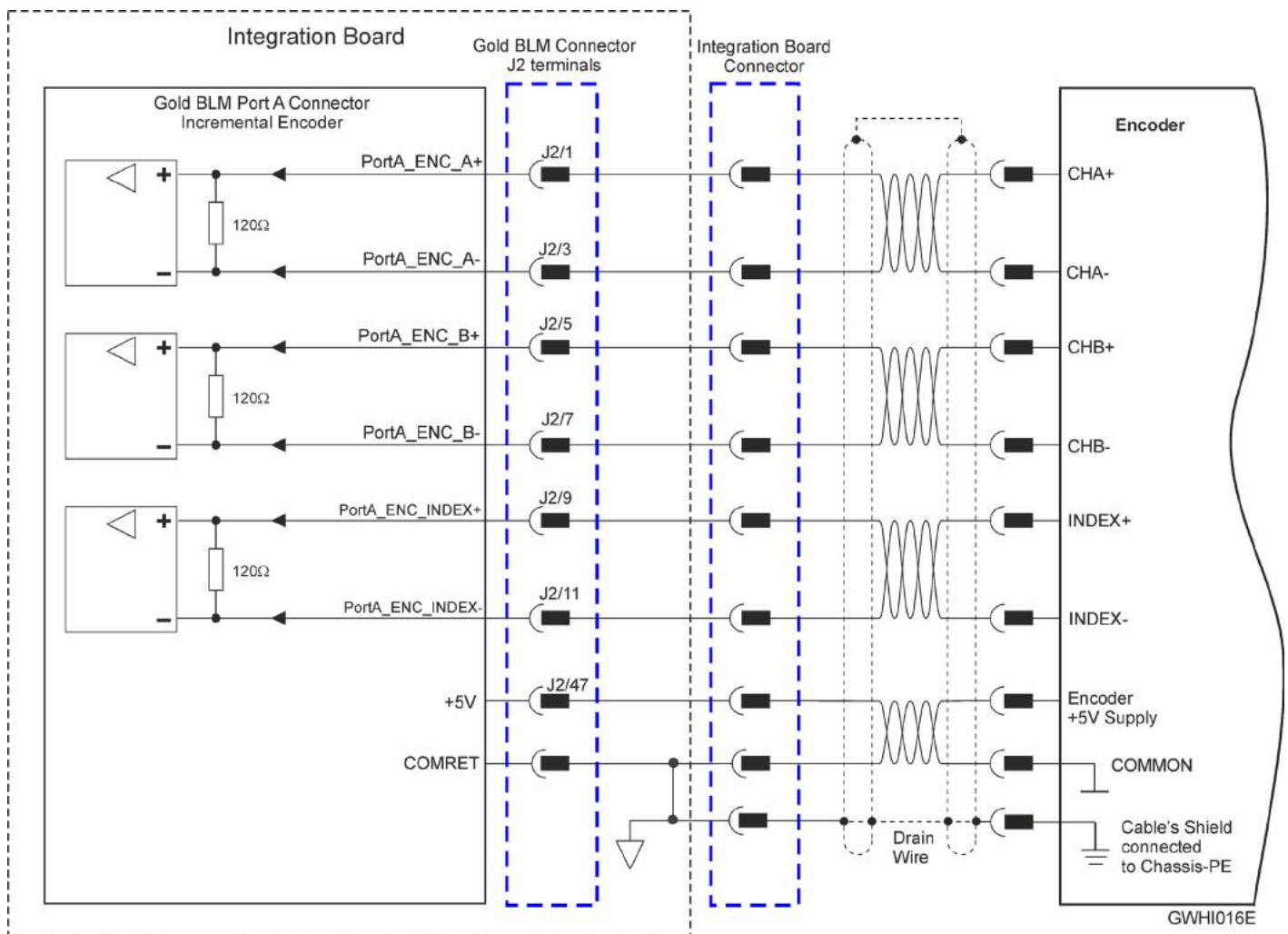

Figure 10: Port A Incremental Encoder Input – Recommended Connection Diagram



9.6.1.2. Hall Sensors

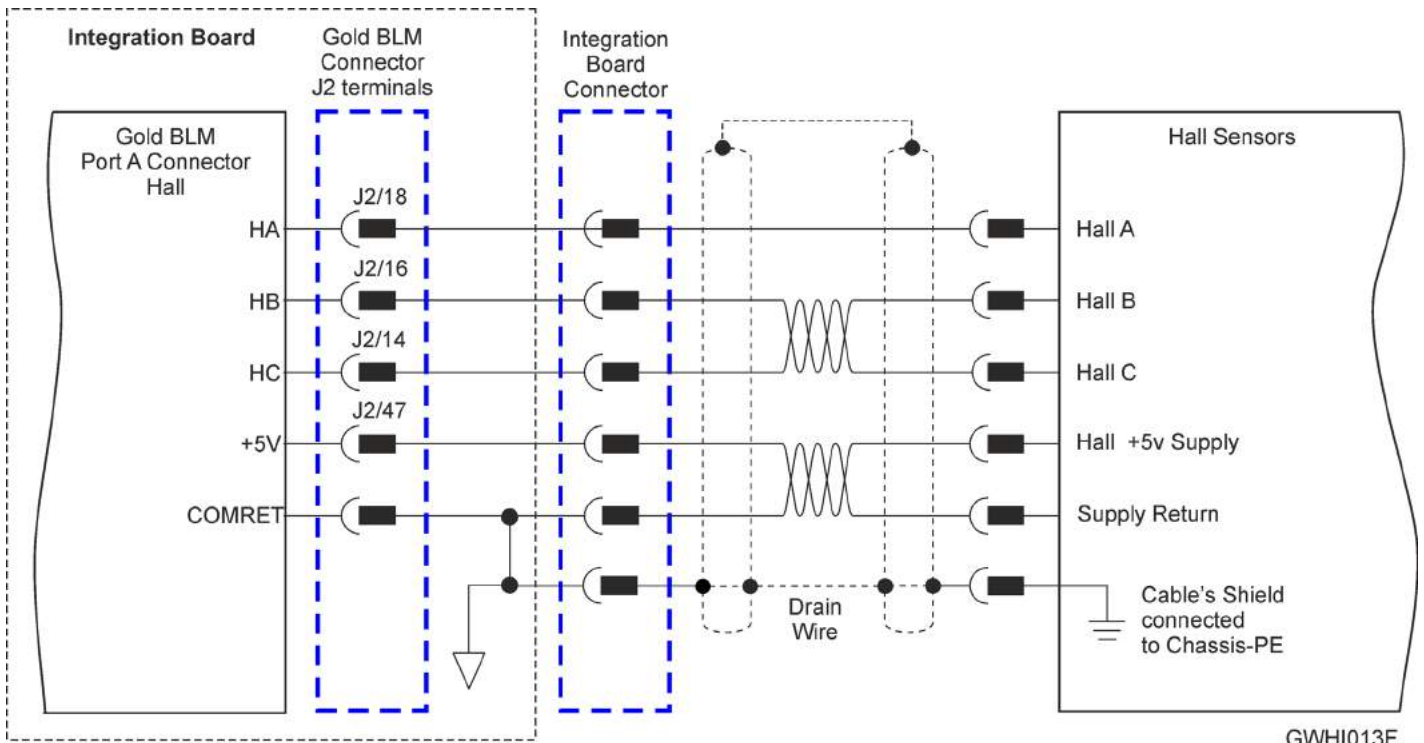

Figure 11: Hall Sensors Connection Diagram



9.6.1.3. Absolute Serial Encoder

The following Absolute Encoder are supported:

- Endat 2.2
- Biss C and Biss B
- Panasonic
- Tamagawa
- SSI
- Sanyo Danki
- Hiperface

The following is the diagram connection of the Endat, Biss, SSI:

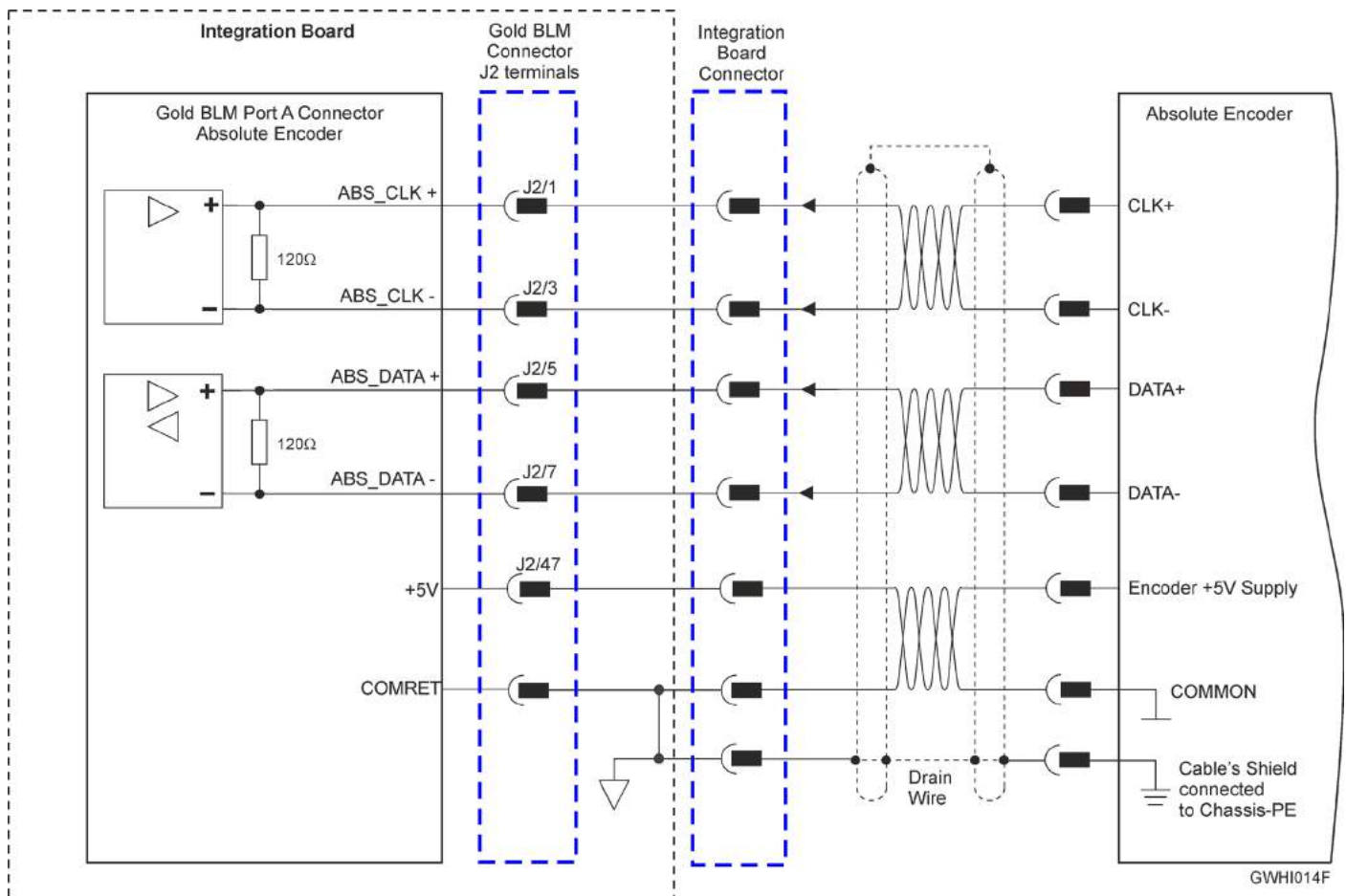

Figure 12: Absolute Serial Encoder – Recommended Connection Diagram for Endat, Biss, SSI



The following is the diagram connection of the Panasonic, Tamgawai, Sanyo-Danki:

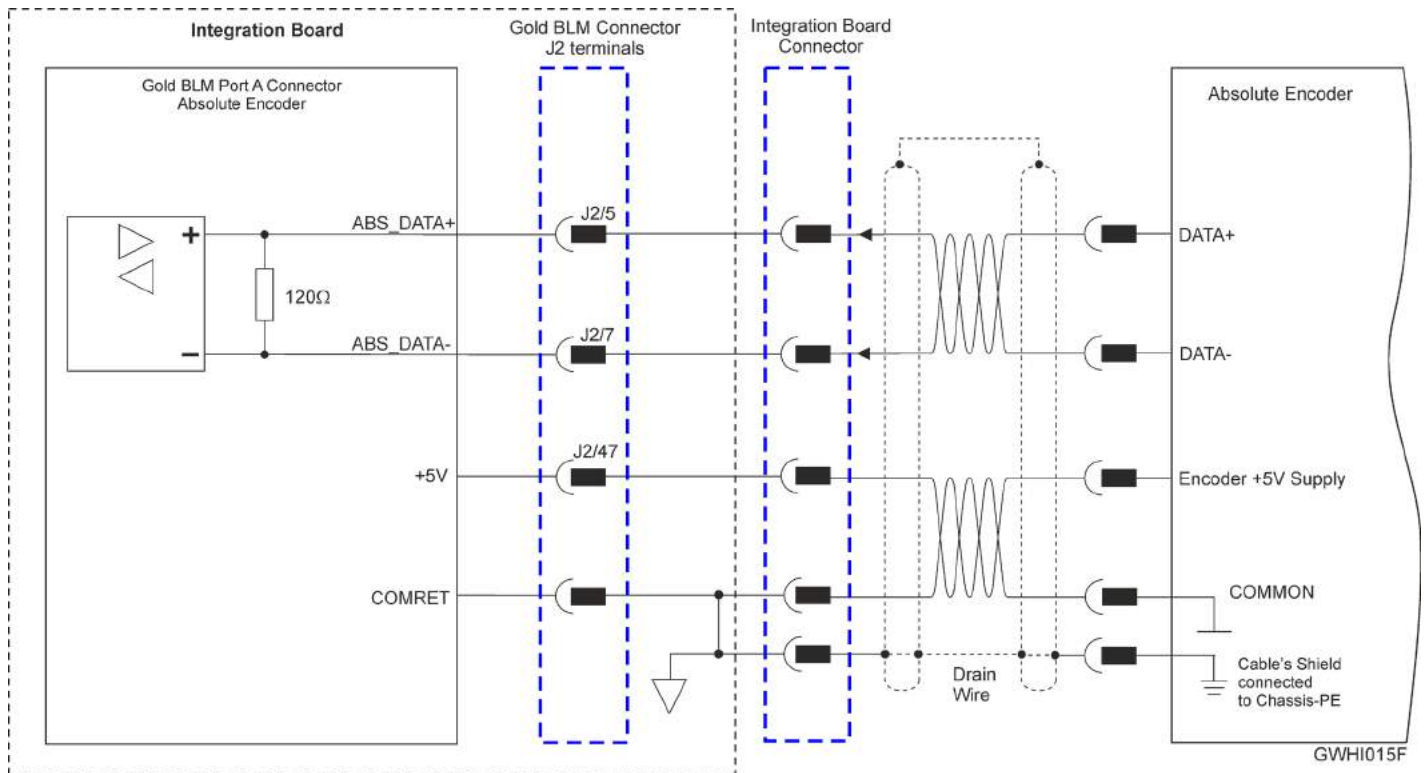

Figure 13: Absolute Serial Encoder – Recommended Connection Diagram for Panasonic, Tamgawai, Sanyo-Danki



9.6.1.4. Hiperface

The following figure describes the connection diagram.

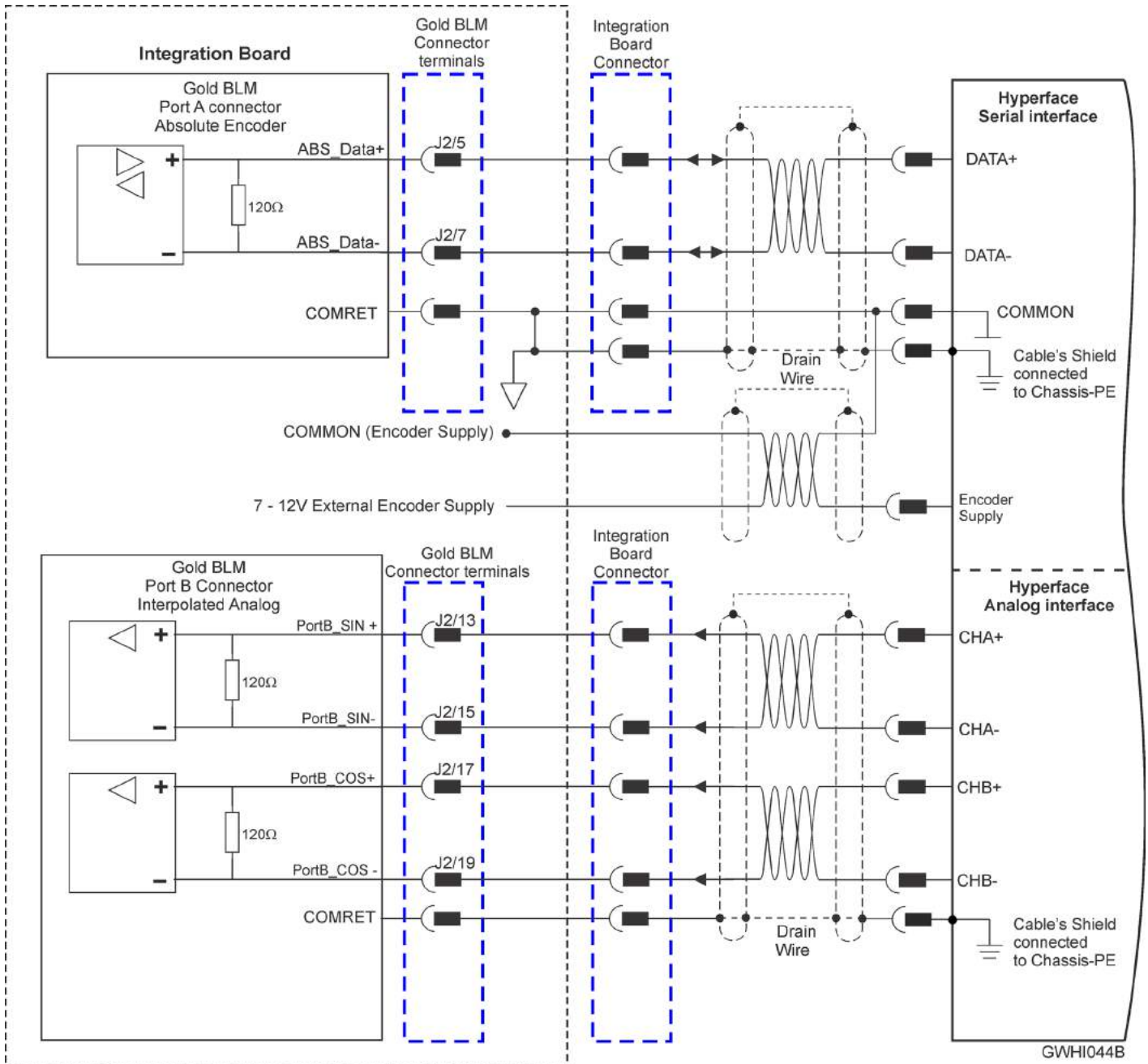

Figure 14: Absolute Serial Encoder – Recommended Connection Diagram for Stegmann Hiperface

Note: When the Hiperface protocol is used the RS232 is not available



9.6.2. Feedback Port B

Port B supports any of the following sensors:

- Incremental encoder, interpolated analog encoder or analog Hall sensors

Or

- Resolver (separate hardware option)

Differential PWM signal input can be connected to port B

Differential Pulse & Direction signal inputs can be connected to port B

9.6.2.1. Incremental Encoder

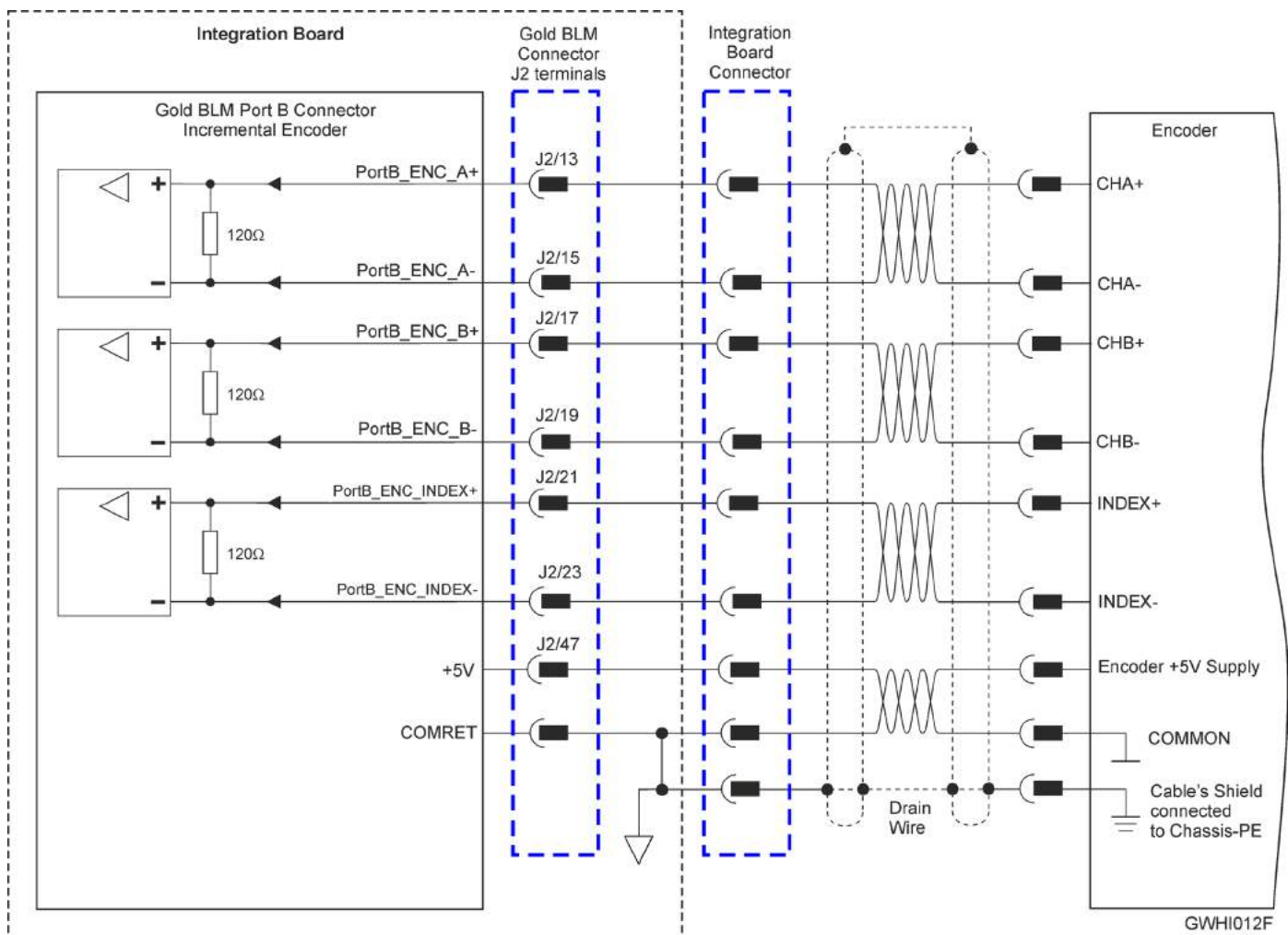

Figure 15: Port B Incremental Encoder Input – Recommended Connection Diagram



9.6.2.2. Interpolated Analog (Sine/Cosine) Encoder

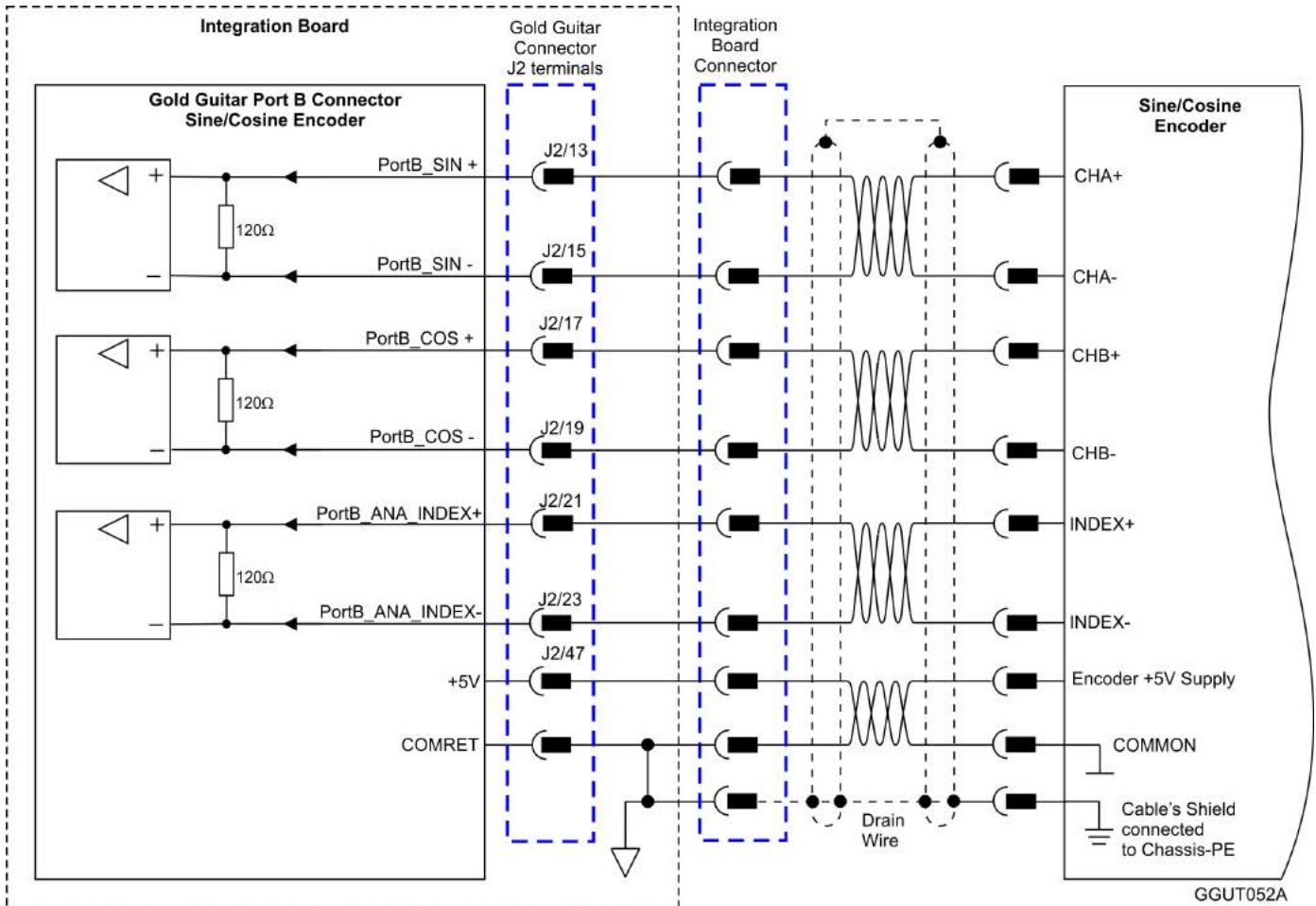

Figure 16: Port B - Interpolated Analog Encoder Connection Diagram



9.6.2.3. Resolver

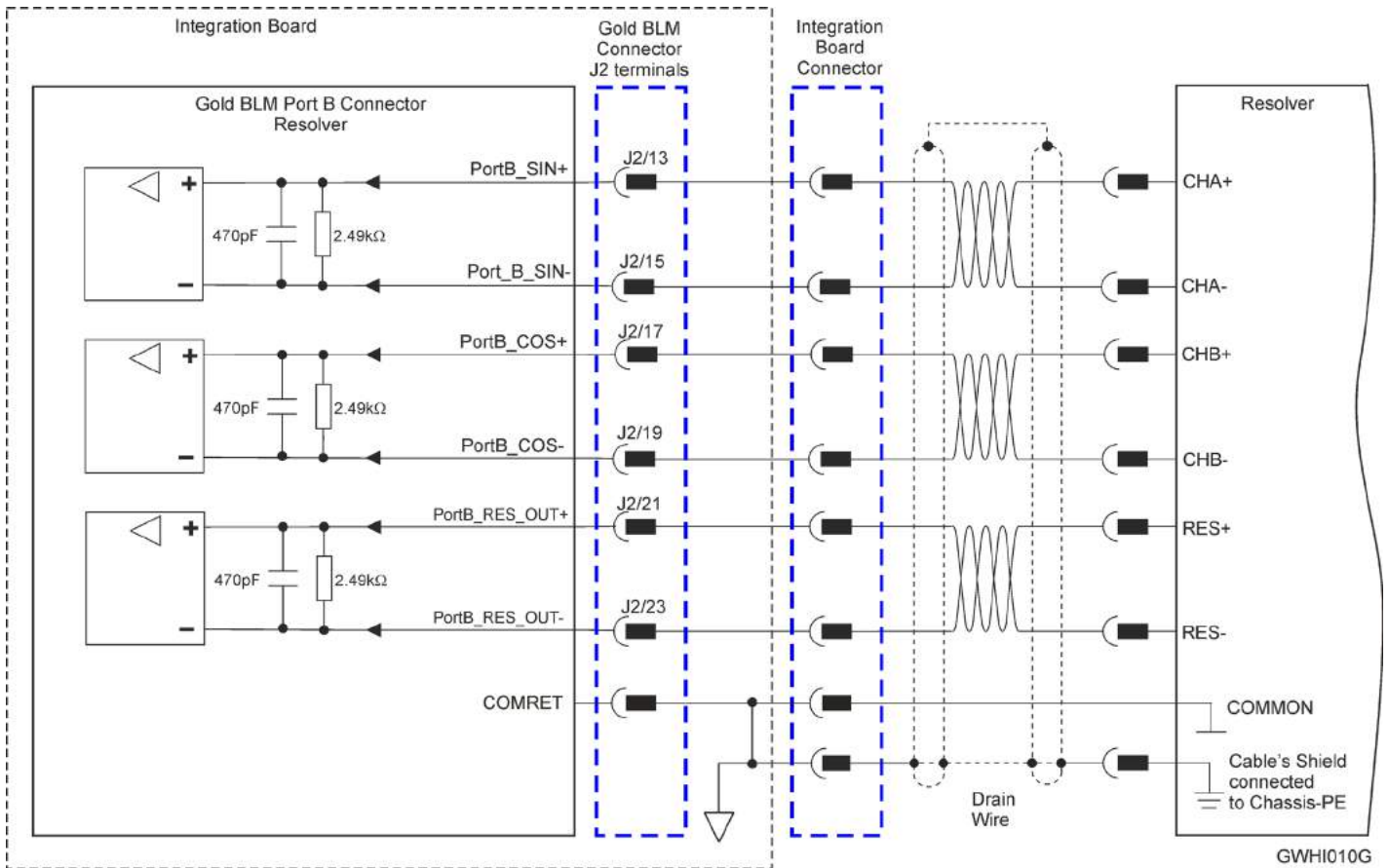

Figure 17: Port B – Resolver Connection Diagram



9.6.3. Port C – Emulated Encoder Output

Port C provides emulated encoder output derived from port A or port B feedback inputs, or from internal variables.

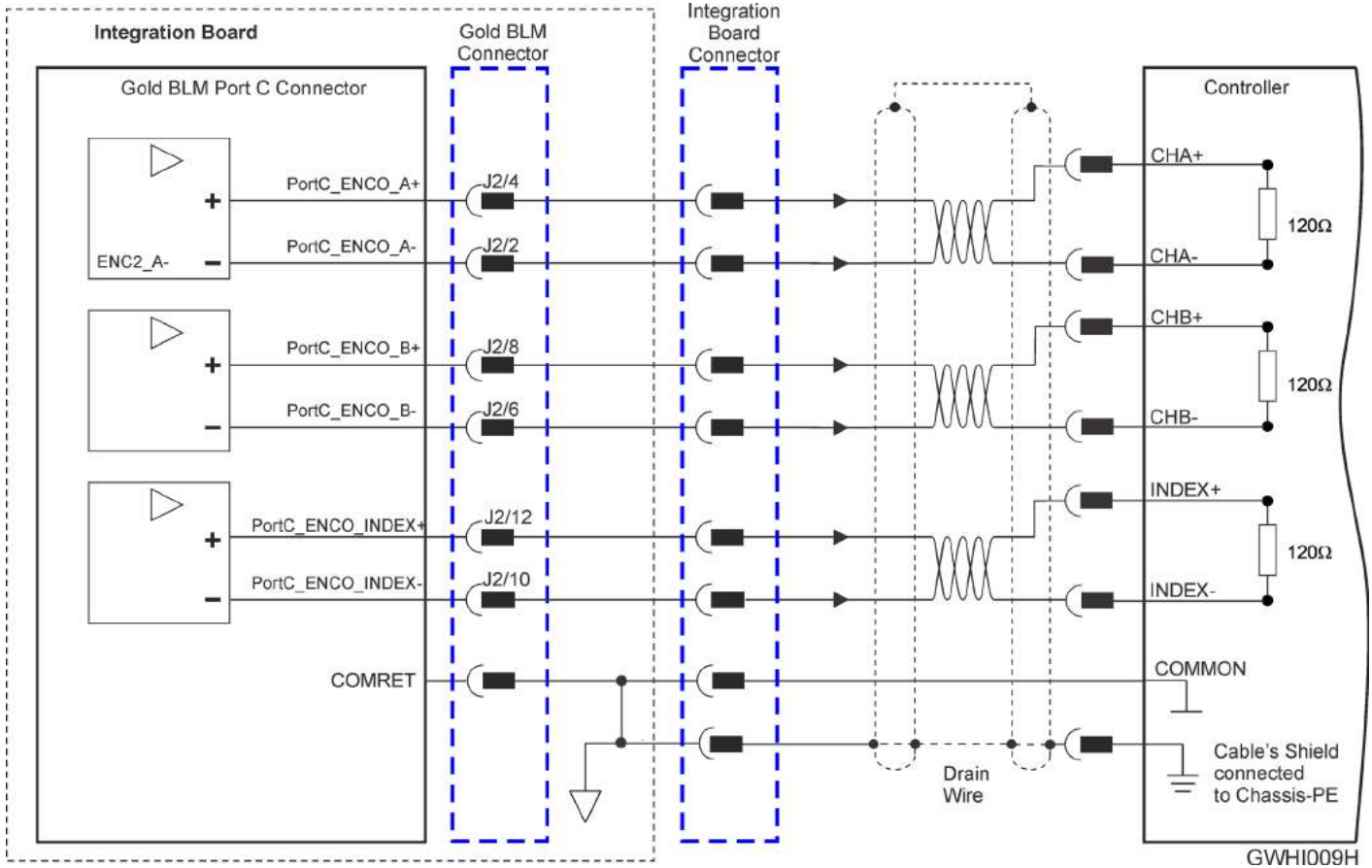

Figure 18: Emulated Encoder Differential Output – Recommended Connection Diagram



9.6.4.2. Analog Input 2

The Gold Guitar allows an additional single ended Analog input. Figure 20 describes the input interface of the Analog_input2 in the Gold Guitar. It also describes implementation examples for a differential analog input of 10V:

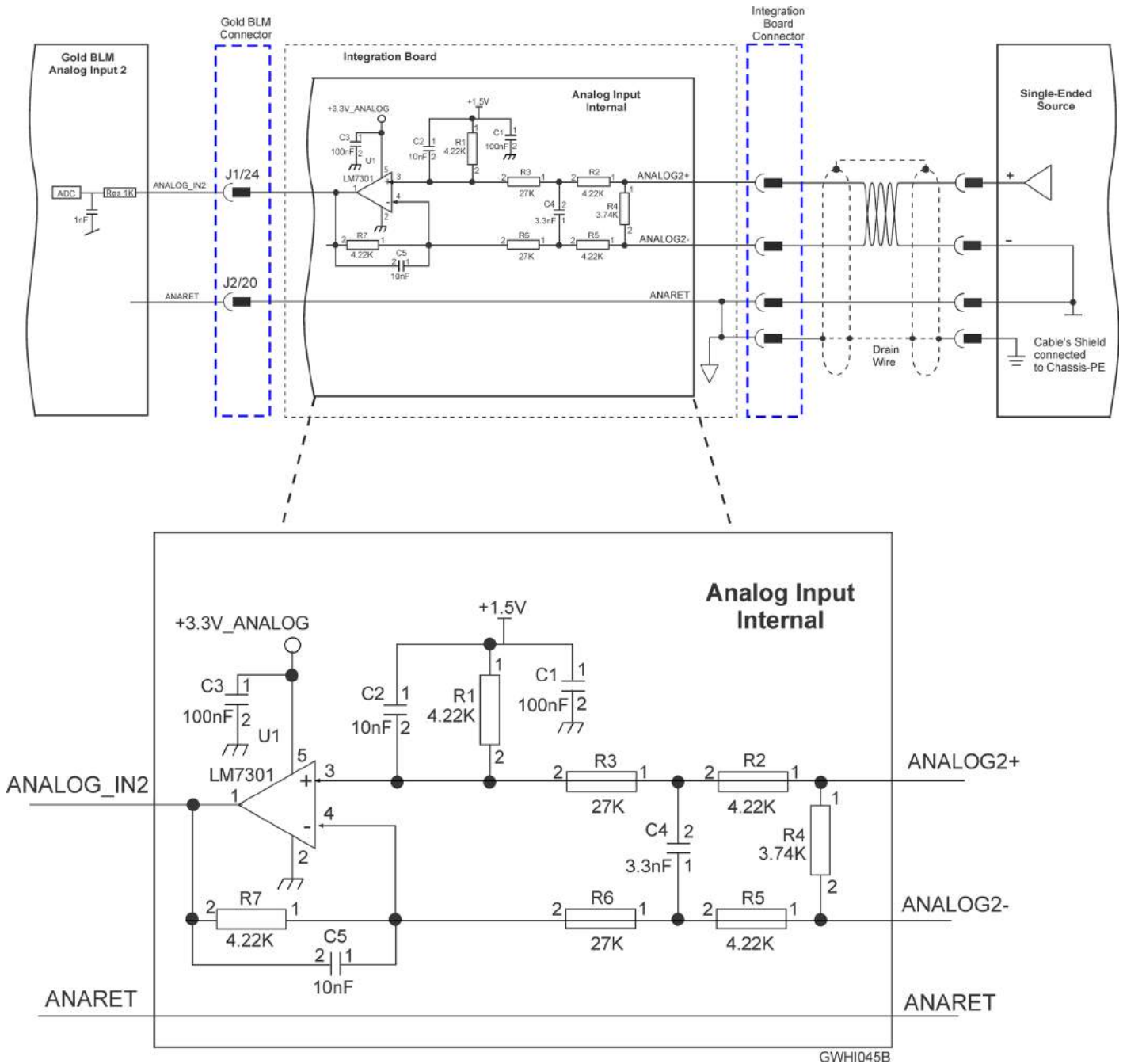

Figure 20: Analog Input 2 Example



9.6.5. RS232 TTL Logic Level

Figure 21 describes the standard RS232 connection diagram.

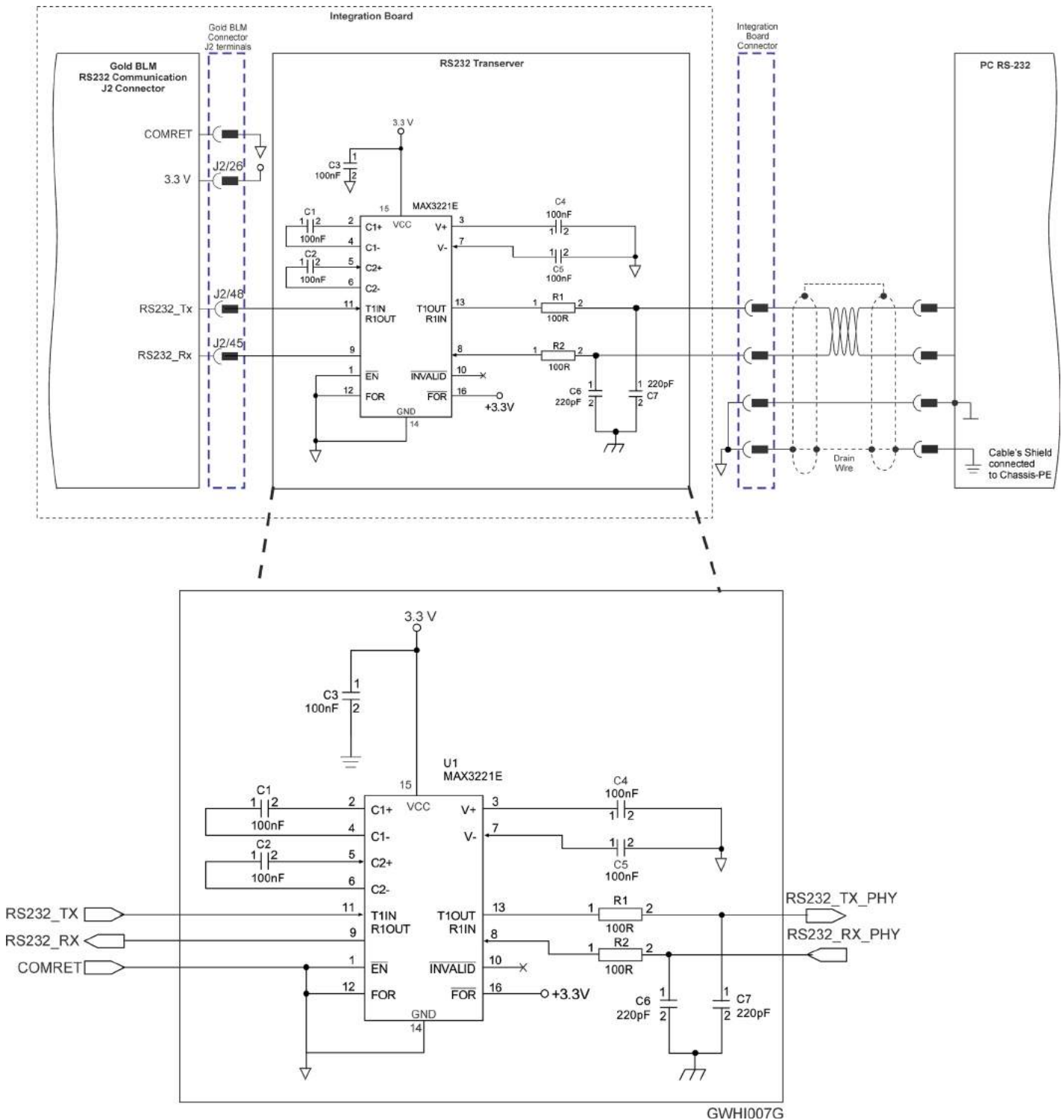

Figure 21: Standard RS232 Voltage Level incorporating RS232 TX/RX Transceiver Connection Diagram



9.6.6. USB 2.0

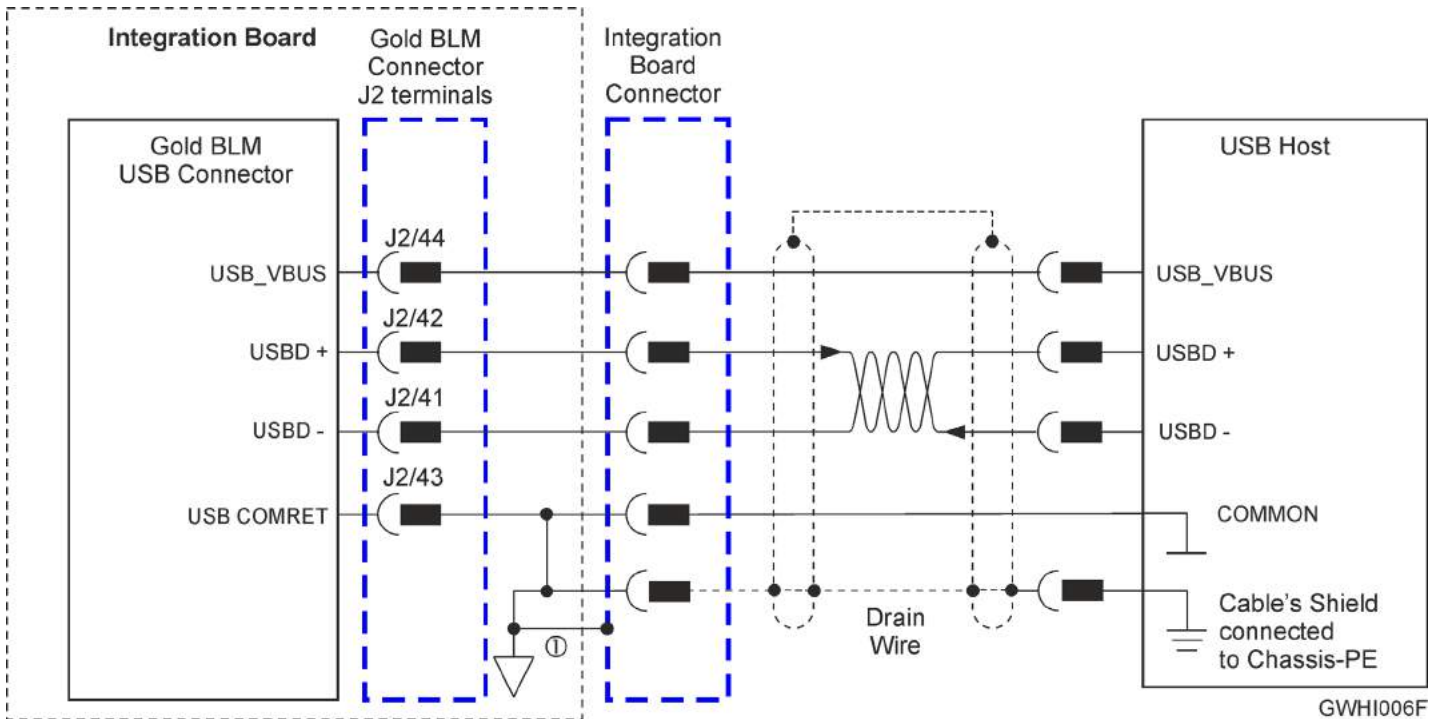

Figure 22: USB Network Diagram

Note ①: In the Gold Guitar the shield of the USB connector should be connected to the COMRET and not the PE.



9.6.7. EtherCAT/Ethernet

The Gold Guitar serves as an EtherCAT slave device, therefore it includes EtherCAT_IN and EtherCAT_OUT ports. It also includes LED indicators. The EtherCAT_IN port can be configured to an Ethernet port.

The following figure describes EtherCAT connection with a standard RJ-45 connector that includes transformer isolation.

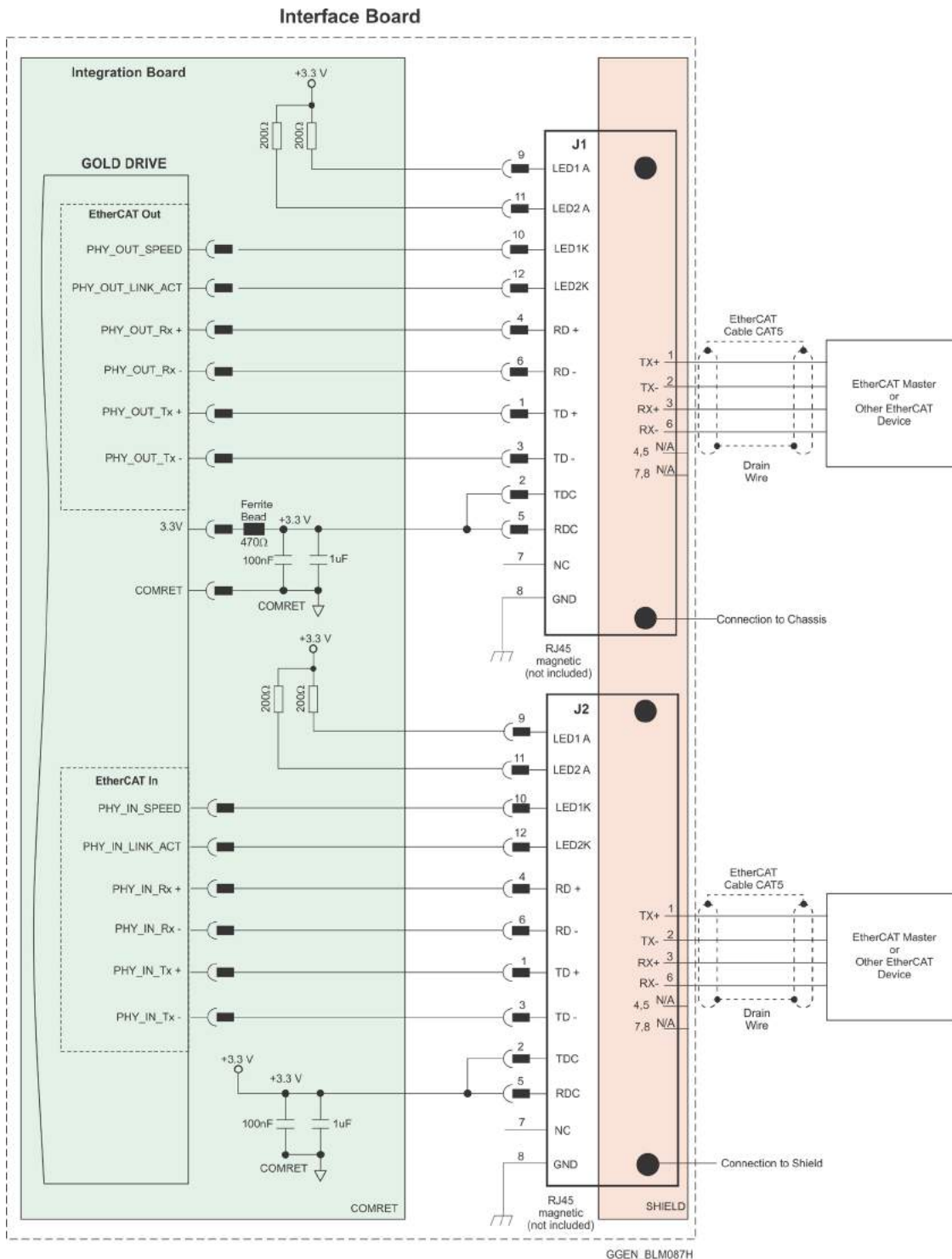

Figure 23: EtherCAT Connection Schematic with Diagram Sign of 3.3V



9.6.8. CAN

Figure 24 displays the CAN connectivity.

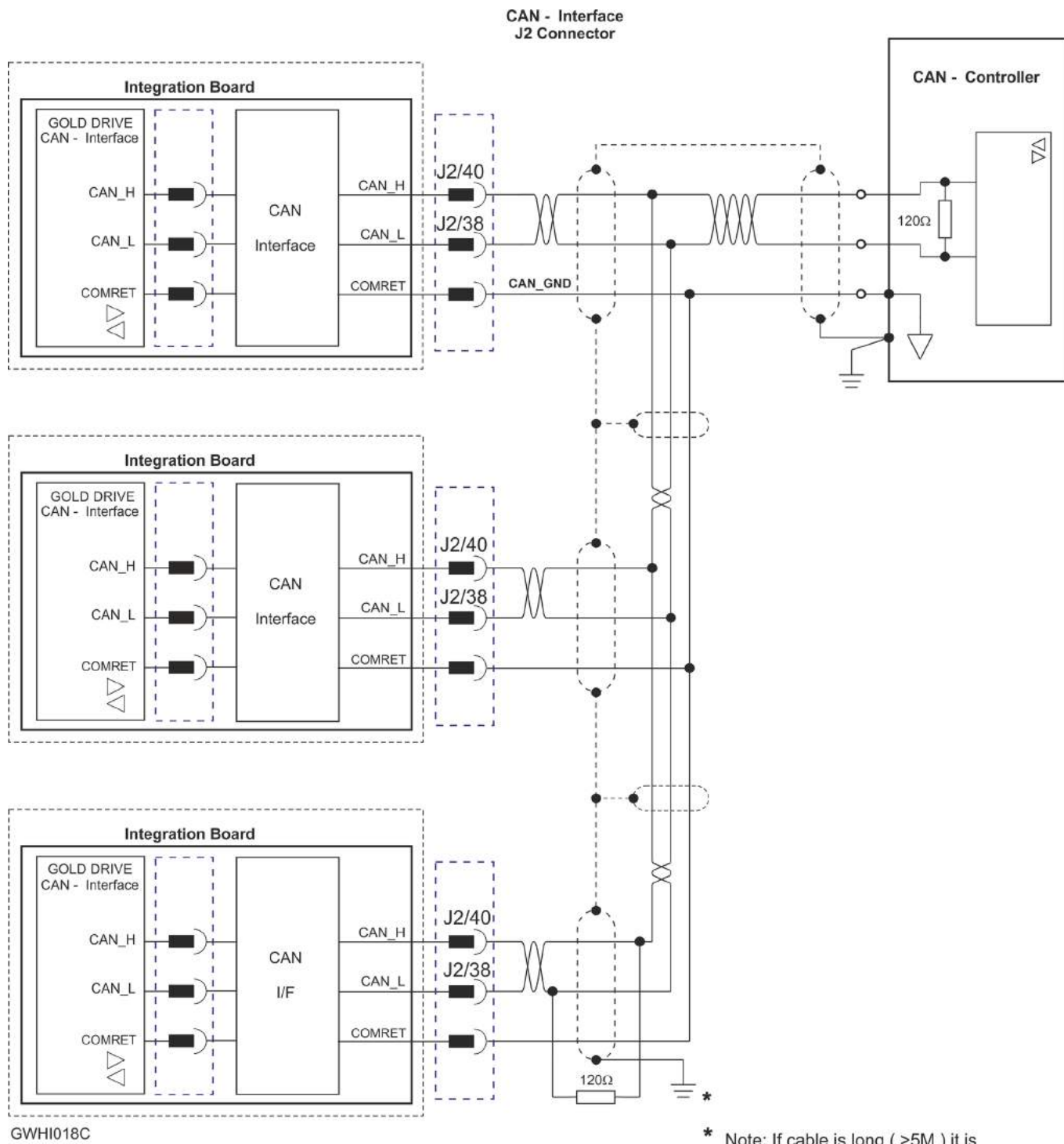

Figure 24: CANbus Connections

Important:

A 120 Ω termination resistor should be connected at each end of the network cable.



9.7. Connector J1 - Digital I/O, Analog Inputs, LEDs and STO

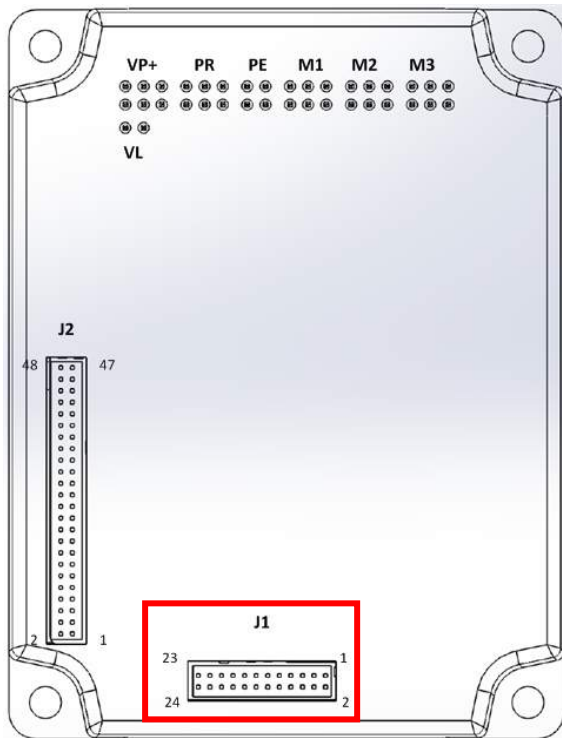

For full details on Digital and Analog I/Os, see Chapter 11 and 12 in the MAN-G-Board Level Modules Hardware Manual.

For full details on the LEDs, see Chapter 7 Drive Status Indicator, and section 14.2.6 EtherCAT Status Indicator in the in the MAN-G-Board Level Modules Hardware manual for full details.

For full details on STO, see Chapter 9 in the in the MAN-G-Board Level Modules Hardware manual for full details.

Connector Type: 1.27 mm pitch 0.41 mm sq

| Pin (J1) | Signal | Function |
|----------|------------------|--|
| 1 | SB_Load | Serial Bus Load for extended IO (refer to Chapter 13 of the MAN-G-Board Level Modules Hardware Manual) |
| 2 | SB_Clock | Serial Bus_Clock (9.375Mhz) for extended IO (refer to Chapter 13 of the MAN-G-Board Level Modules Hardware Manual) |
| 3 | INRET1_6 | Programmable digital inputs 1–6 return |
| 4 | IN1 | Programmable digital input 1 |
| 5 | IN2 | Programmable digital input 2 |
| 6 | IN3 | Programmable digital input 3 |
| 7 | IN4 | Programmable digital input 4 |
| 8 | IN5 | Programmable digital input 5 |
| 9 | IN6 | Programmable digital input 6 |
| 10 | STO_RET | STO signal return |
| 11 | STO2 | STO 2 input |
| 12 | STO1 | STO 1 input |
| 13 | LED_ETHERCAT_ERR | LED Status EtherCAT ERR |



| Pin (J1) | Signal | Function |
|----------|------------------|--|
| 14 | LED_ETHERCAT RUN | LED Status EtherCAT RUN |
| 15 | OUT2 | Programmable output 2 |
| 16 | OUT1 | Programmable output 1 |
| 17 | OUTRET2 | OUT 2 return |
| 18 | OUTRET1 | OUT 1 return |
| 19 | LED2 | Bi-color indication output 2 (Cathode) |
| 20 | LED1 | Bi-color indication output 1 (Cathode) |
| 21 | OUT4 | Programmable output 4 not isolated (3.3V TTL level) |
| 22 | OUT3 | Programmable output 3 not isolated (3.3V TTL level) |
| 23 | COMRET | Common return |
| 24 | ANALOG_IN2 | Analog input 2 |

Table 6: Connector J1 – I/O, LEDs



9.7.1. Digital Inputs

9.7.1.1. TTL voltage level

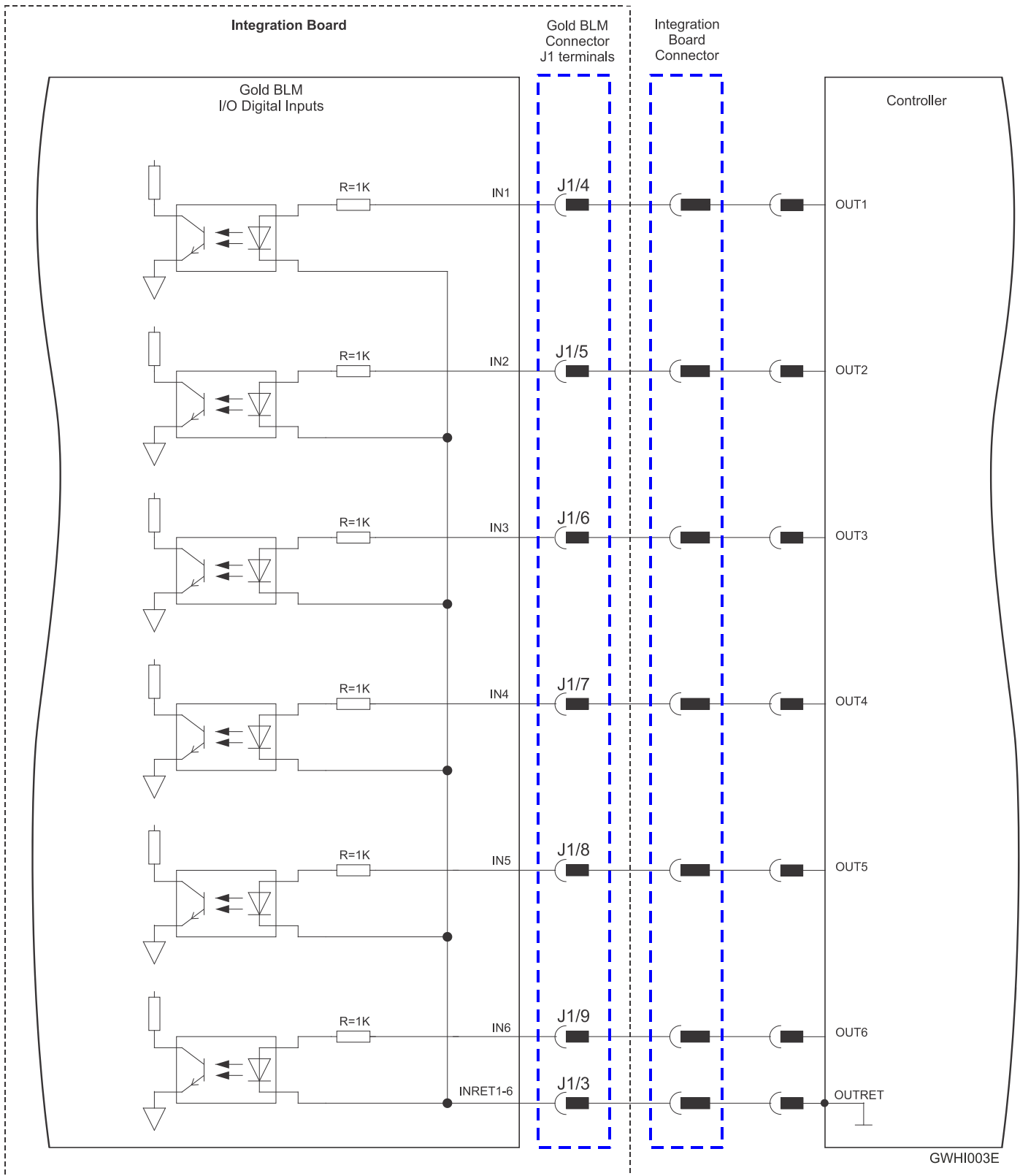

Figure 25: Digital Input TTL Mode Connection Diagram



9.7.2. Digital Outputs

9.7.2.1. Isolated Open Collector and Open Emitter

The following diagram describes the OUT1 and OUT2 outputs:

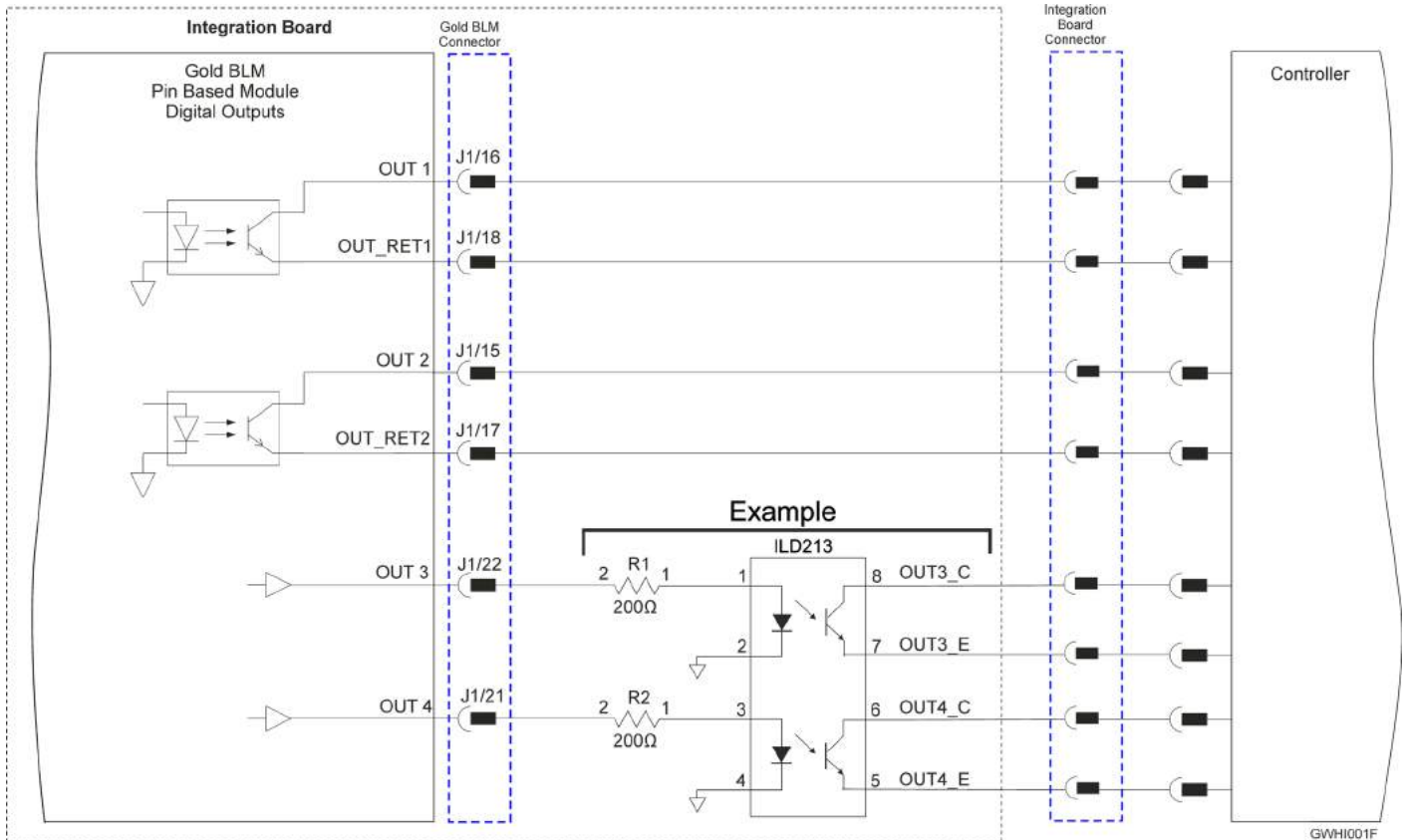

Figure 26: Digital Output Connection Diagram – Isolated Open Collector and Open Emitter Connection

9.7.3. Analog Inputs

For details of the Analog Input 2 – Single ended using Connector J1 in the Gold Guitar, refer to the section 9.6.4 Analog Inputs for details.



9.7.4. STO Input Interfaces - TTL Mode

The diagram below describes the TTL option connection for the STO input interfaces.

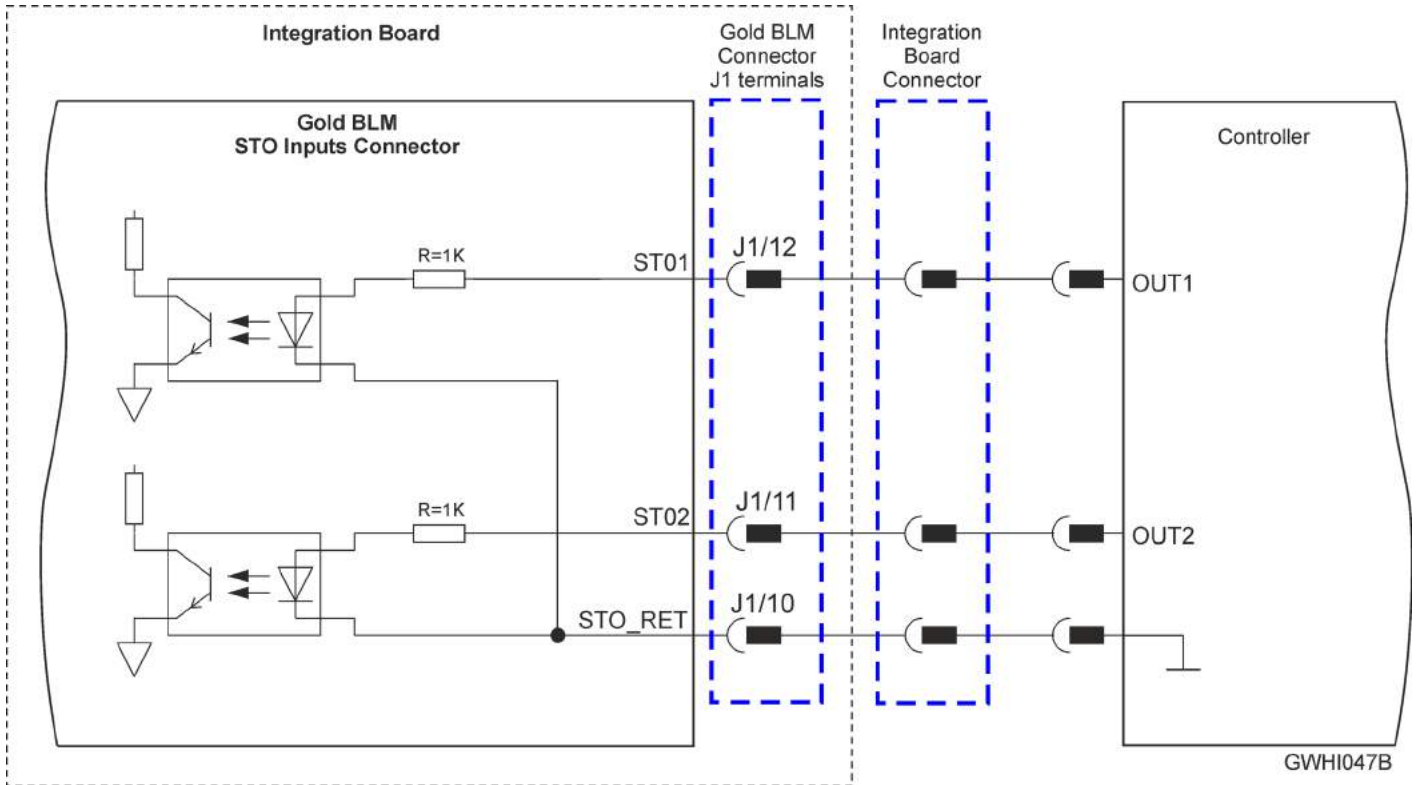

Figure 27: STO Input Connection – TTL Option

9.7.5. EtherCAT Status Indicator

For details of the EtherCAT Status Indicator, refer to the section 14.2.6 EtherCAT Status Indicator in the in the MAN G Board Level Modules Hardware manual for full details.



Chapter 10: Powering Up

After the Gold Guitar is connected to its device, it is ready to be powered up.



Caution:

Before applying power, ensure that the DC supply is within the specified range and that the proper plus-minus connections are in order.

10.1. Initializing the System

After the Gold Guitar has been connected and mounted, the system must be set up and initialized. This is accomplished using the *EASII*, Elmo's Windows-based software application. Install the application and then perform setup and initialization according to the directions in the *EASII User Manual*.



Chapter 11: Heat Dissipation

The best way to dissipate heat from the Gold Guitar is to mount it so that its heat-sink faces up. For best results leave approximately 10 mm of space between the Gold Guitar's heat-sink and any other assembly.

11.1. Thermal Data

- Heat dissipation capability (θ): Approximately 10 °C/W
- Thermal time constant: Approximately 240 seconds (thermal time constant means that the Gold Guitar will reach 2/3 of its final temperature after 4 minutes)
- Shut-off temperature: 86 °C to 88 °C (measured on the heat-sink)

11.2. Heat Dissipation Data

Heat Dissipation is shown in graphically below:

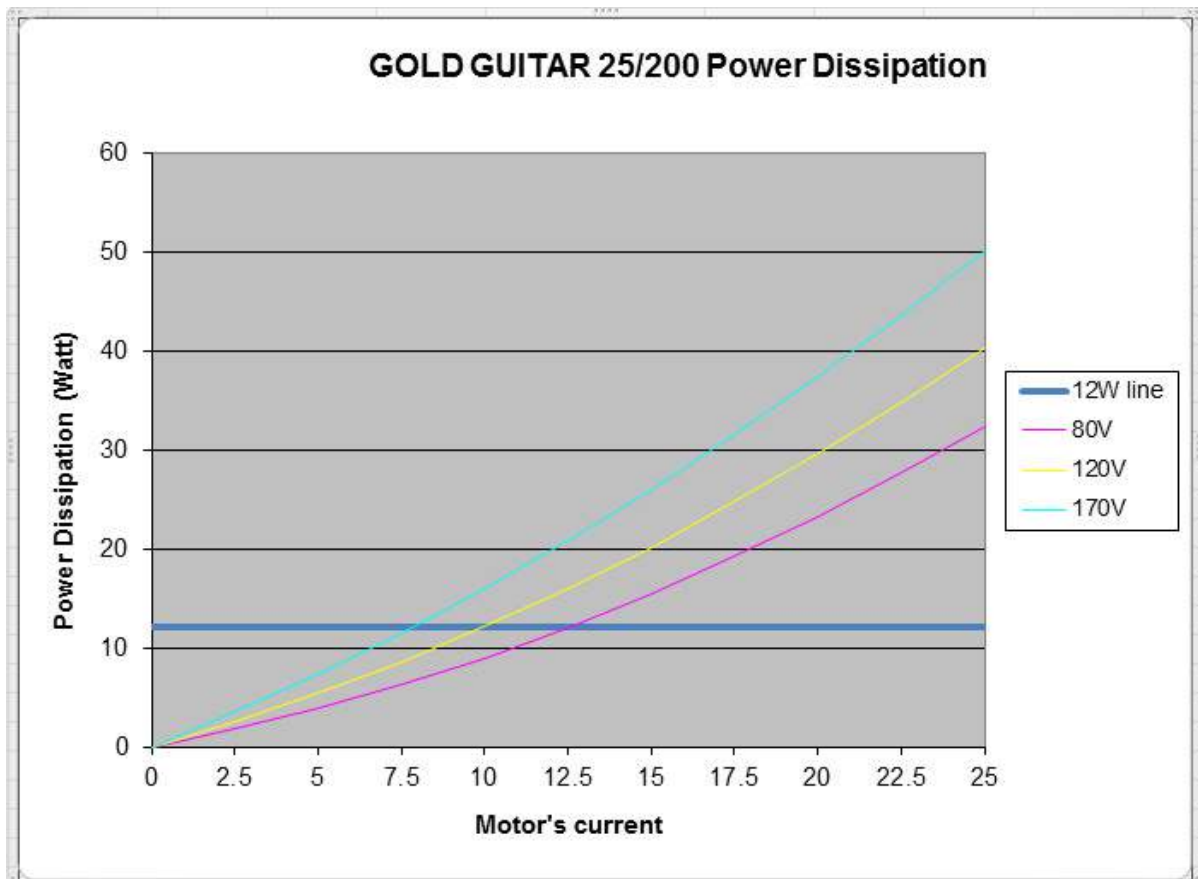

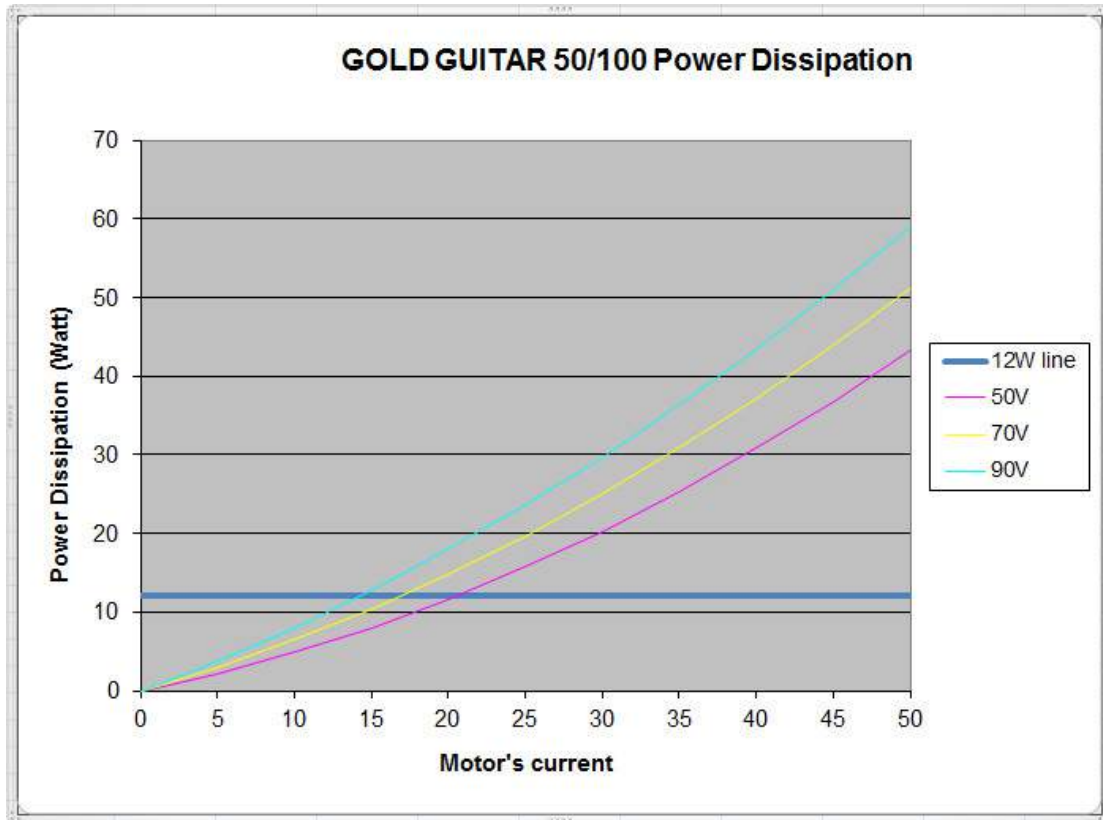

11.3. How to Use the Charts

The charts above are based upon theoretical worst-case conditions. Actual test results show 30% to 50% better power dissipation.

To determine if your application needs a heat-sink:

1. Allow maximum heat-sink temperature to be 80 °C or less.
2. Determine the ambient operating temperature of the Gold Guitar.
3. Calculate the allowable temperature increase as follows:
 - for an ambient temperature of 40 °C , $\Delta T = 80 \text{ °C} - 40 \text{ °C} = 40 \text{ °C}$
4. Use the chart to find the actual dissipation power of the drive. Follow the voltage curve to the desired output current and then find the dissipated power.
5. If the dissipated power is below 4 W the Gold Guitar will need no additional cooling.

Notes:

- The chart above shows that no heat-sink is needed when the heat-sink temperature is 80 °C, ambient temperature is 40 °C and heat dissipated is 4 W.
- When an external heat-sink is required, you can use the Elmo external heat-sink (Catalog number: WHI-HEAT-SINK-2).



Chapter 12: Dimensions

This chapter provides detailed technical information regarding the Gold Guitar.

