

Type A

● SPECIFICATION

MODEL TYPE	PSW-1211	PSW-1311	PSW-1514	PSW-1515	PSW-1715	PSW-1915
· ABSORBED POWER (kW)	15	22	30	13.2	60	90
· ABSORBED TORQUE (kN·m)	1.35	1.9	8	13.2	22	31
· MAX SPEED (min ⁻¹)	1,800	1,500	1,000	600	600	500
· COOLING WATER (ℓ/min)	10	15	20	40	40	60
· MAX SET AIR PRESSURE (MPa)	0.7					

Hydraulic Servo (Hydraulic Control) Type is also available.

● DIMENSION LIST

Model Type	A	B	C	φD	E	F	G	H	I	J	K	φd	ℓ	N-φZ
PSW-1211	632	480	430	270	35.5	725	350	300	412	270	10	50	60	4-φ16
PSW-1311	715	540	500	350	60	800	470	390	460	270	19	60	85	4-φ18
PSW-1514	215	800	650	500	275	1,224	580	500	702	400	42	100	150	6-φ23
PSW-1515	1,215	800	650	500	275	1,275	580	500	702	400	42	100	150	6-φ23
PSW-1715	1,580	1,000	750	755	355	1,529	1,150	1,030	1,070	650	20	140	200	8-φ25
PSW-1915	1,580	1,000	900	1,000	280	1,774	1,600	1,500	1,300	750	30	140	200	8-φ27

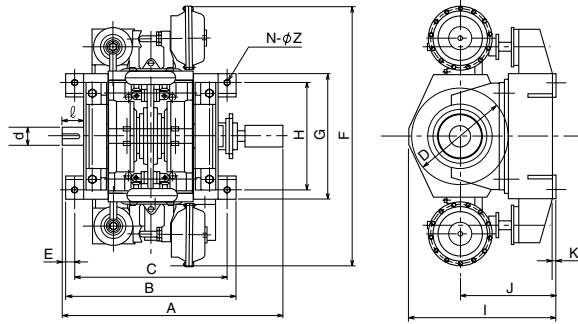

Type B

● SPECIFICATION

MODEL TYPE	PSW-1221	PSW-1321	PSW-1525	PSW-1725
· ABSORBED POWER (kW)	30	45	60	120
· ABSORBED TORQUE (kN·m)	2.7	3.8	26.4	44
· MAX SPEED (min ⁻¹)	1,800	1,500	1,000	600
· COOLING WATER (ℓ/min)	20	30	40	80
· MAX SET AIR PRESSURE (MPa)	0.7			

Hydraulic Servo (Hydraulic Control) Type is also available.

● DIMENSION LIST

Model Type	A	B	C	φD	E	F	G	H	I	J	K	L	φd	ℓ	N-φZ
PSW-1221	1,340	940	395	270	135	680	520	450	510	300	20	230	75	120	4-φ24
PSW-1321	1,309	910	380	350	145	800	600	540	600	350	20	280	80	120	4-φ24
PSW-1525	1,880	1,450	420	500	190	1,120	900	800	950	650	30	380	120	180	6-φ24
PSW-1725	2,150	1,550	450	750	240	1,370	1,200	1,070	1,150	650	40	500	140	220	8-φ30

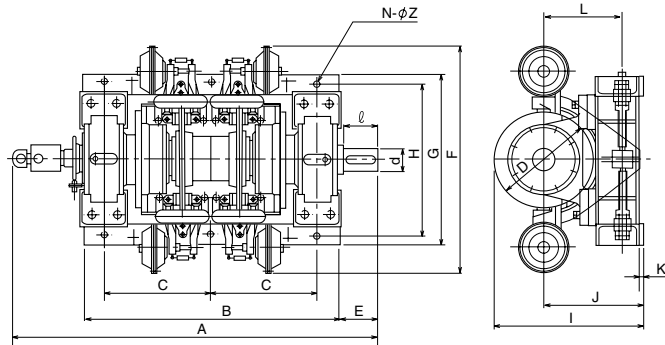

Type C

● SPECIFICATION

MODEL TYPE	PSW-1331	PSW-1535	PSW-1735
· ABSORBED POWER (kW)	67.5	90	180
· ABSORBED TORQUE (kN·m)	5.7	39.6	66
· MAX SPEED (min ⁻¹)	1,500	1,000	600
· COOLING WATER (ℓ/min)	45	60	120
· MAX SET AIR PRESSURE (MPa)	0.7		

Hydraulic Servo (Hydraulic Control) Type is also available.

● DIMENSION LIST

Model Type	A	B	C	φD	E	F	G	H	I	J	K	L	φd	ℓ	N-φZ
PSW-1331	1,578	1,180	515	350	145	800	600	540	600	350	40	280	90	120	6-φ25
PSW-1535	2,390	1,900	425	500	190	1,120	900	800	950	650	40	380	120	180	10-φ24
PSW-1735	2,600	2,000	450	750	240	1,370	1,200	1,070	1,150	650	40	500	140	220	10-φ30

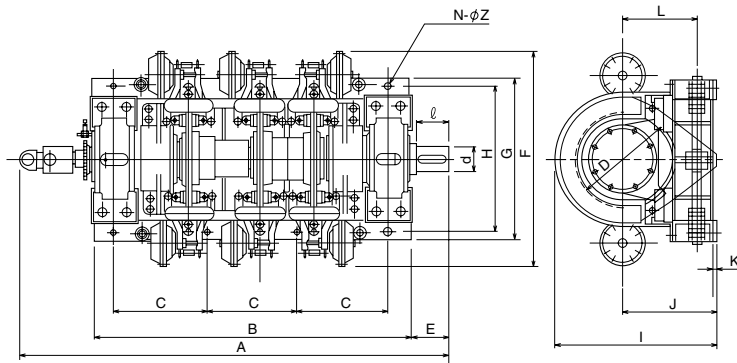

*Dimensions and specifications might be changed for improvement without notice.