

# Incremental Rotary Encoder G58

Shaft: Type S / L / H

Hollow shaft: Type W



- Housing diameter: 58 mm
- Shaft: 6 ... 10 mm
- Hollow shaft: 6 ... 14 mm
- Line counts: 2 ... 10.000
- Output signals: RS422, KI, KS, HTL, TTL, OC, 1Vpp, 11µApp
- Connector or cable output: axial or radial

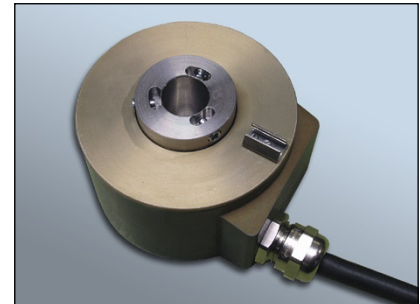

## Mechanical Data

G 58	Shaft			Hollow shaft
	Type S	Type L	Type H	Type W
Shaft / Hollow shaft	6 or 10 mm	6 mm	10 mm	6 ... 14 mm
Weight	approx. 320 g	approx. 300 g	approx. 320 g	approx. 320 g
Accuracy (up to line count 2500)	$< \pm \frac{360^\circ}{\text{Line count} \times 20}$	$< \pm \frac{360^\circ}{\text{Line count} \times 20}$	$< \pm \frac{360^\circ}{\text{Line count} \times 20}$	$< \pm \frac{360^\circ}{\text{Line count} \times 20}$
Mech. permissible speed	max. 12.000 min <sup>-1</sup>	max. 12.000 min <sup>-1</sup>	max. 12.000 min <sup>-1</sup>	max. 12.000 min <sup>-1</sup>
Starting torque (25 °C)	< 0,005 Nm	< 0,003 Nm	< 0,01 Nm	< 0,01 Nm
Shaft load at 6.000 min <sup>-1</sup> at 12.000 min <sup>-1</sup>	40 N axial; 60 N radial 12 N axial; 25 N radial	20 N axial; 30 N radial 10 N axial; 20 N radial	50 N axial; 65 N radial 15 N axial; 30 N radial	- - - - - -
Rotor inertia	1,7 x 10 <sup>-6</sup> kgm <sup>2</sup>	1,4 x 10 <sup>-6</sup> kgm <sup>2</sup>	1,7 x 10 <sup>-6</sup> kgm <sup>2</sup>	3,5 x 10 <sup>-6</sup> kgm <sup>2</sup>
Vibration	100 m/s <sup>2</sup> ; higher upon request	100 m/s <sup>2</sup> ; higher upon request	100 m/s <sup>2</sup> ; higher upon request	100 m/s <sup>2</sup> ; higher upon request
Shock	1000 m/s <sup>2</sup> higher upon request	1000 m/s <sup>2</sup> higher upon request	1000 m/s <sup>2</sup> higher upon request	1000 m/s <sup>2</sup> higher upon request
Operating temperature	-10 °C ... +80 °C -40 °C ... +100 °C upon request	-10 °C ... +80 °C -40 °C ... +100 °C upon request	-10 °C ... +80 °C -40 °C ... +100 °C upon request	-10 °C ... +80 °C -40 °C ... +100 °C upon request
Protection class	IP 64; IP 66 upon request	IP 64; IP 66 upon request	IP 64; IP 66 upon request	IP 64; IP 66 upon request

## Line Counts

2	8	10	25	50	64	100	120	125	128	150	160	180	190	200
240	250	254	256	300	350	360	380	400	500	512	560	600	604	625
635	676	720	750	800	900	1000	1024	1125	1130	1152	1200	1250	1270	1440
1500	1600	1800	2000	2048	2160	2164	2200	2400	2500	2540	2592	2670	3000	3092
3142	3600	3927	4000	4096	4490	5000	5760	8192	9000	10000	others upon request			

LTN Servotechnik GmbH

### Dimensions (mm)

#### G 58 S

- higher vibration capability upon request
- optional: sealed bearing
- optional: shaft seal
- connector output: radial or axial
- cable output: radial or axial
- ② optional: servo clamps

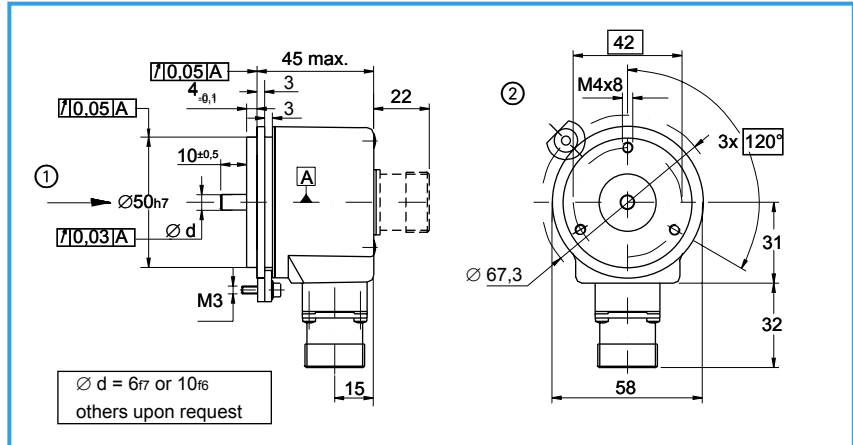

#### G 58 L

- higher vibration capability upon request
- optional: sealed bearing
- optional: shaft seal
- connector output: radial or axial
- cable output: radial or axial
- ② optional: servo clamps

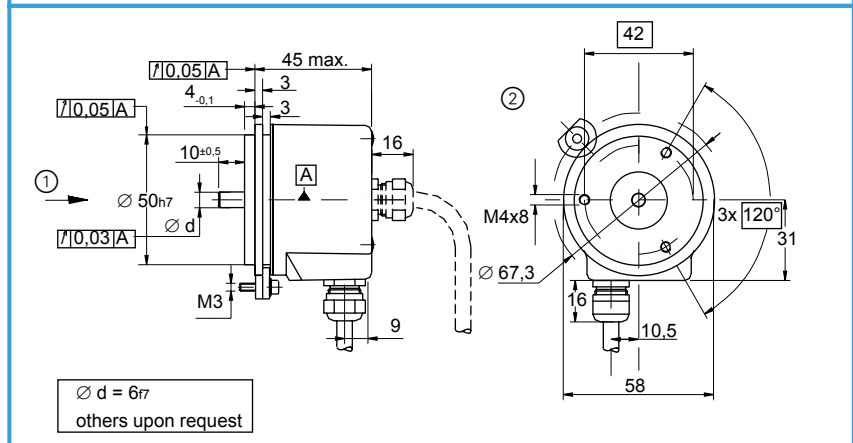

#### G 58 H

- higher vibration capability upon request
- standard: sealed bearing
- connector output: radial or axial
- cable output: radial or axial

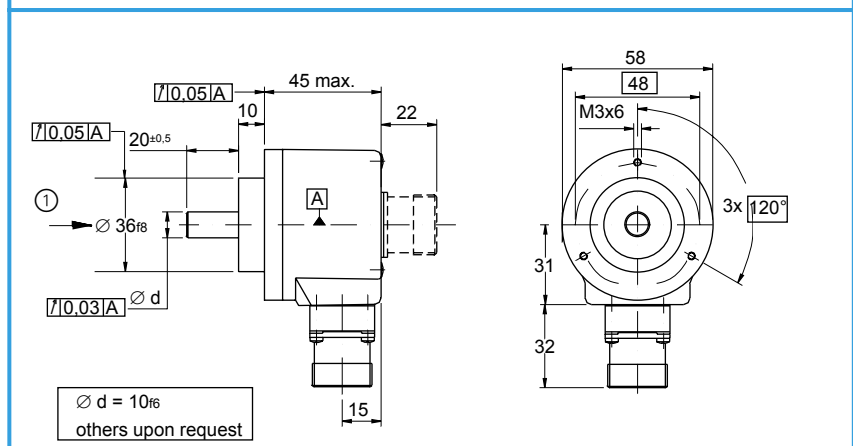

#### G 58 W

- hollow shaft type (blind hole)
- optional: sealed bearing
- connector output: radial or axial
- cable output: radial or axial
- ③ coupling pin 3m6 x 10 included

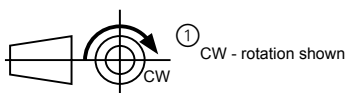
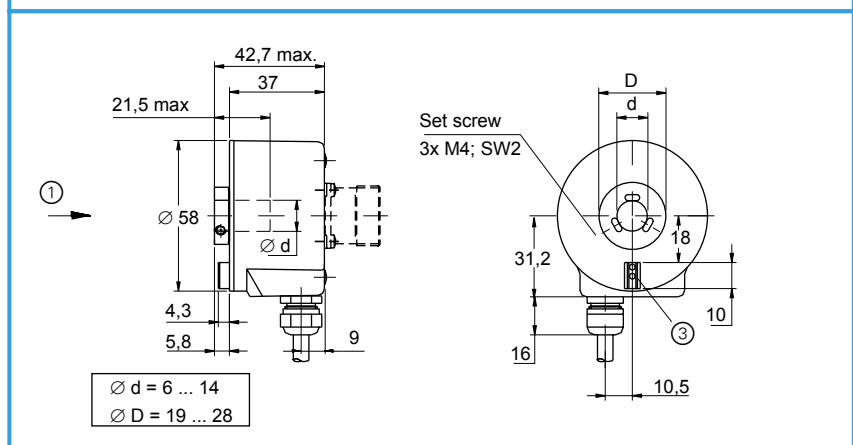

LTN Servotechnik GmbH

### Electrical Data

Output signals	Supply voltage	Output voltage	Current requirements	Output load	Output frequency	Cable length	Interpolation	Zero index
LD (RS422)	5 V	5 V	max. 180 mA	± 20 mA	0 .. 300 kHz	max. 100 m		1)
	8 .. 30 V	5 V						1)
KI	8 .. 30 V	8 .. 30 V	max. 180 mA	50 mA	0 .. 150 kHz	max. 50 m		1)
KS / OC / HL	8 .. 30 V	8 .. 30 V	max. 180 mA	50 mA	0 .. 150 kHz	max. 50 m		1)
TL / OC	5 V	5 V	max. 180 mA	50 mA (incl. 3,3 kΩ)	0 .. 150 kHz	max. 30 m		1)
IX 2)	5 V	5 V	max. 180 mA	± 20 mA	0 .. 400 kHz	max. 100 m	2)	1)
SI	5 V	5 V	max. 180 mA	8 mA (at 120 Ω)	0 .. 160 kHz (-3dB)	max. 150 m		1)
QI	5 V	5 V	max. 100 mA	11 μA (at 1 kΩ)	0 .. 160 kHz (-3dB)	max. 30 m		1)

- 1) 1 = Z "high" if A "high"  
5 = Z "high" if A and B "high"
- 2) 5-fold: IE  
10-fold: IM  
25-fold: IO  
50-fold: IP

### Output Signals

#### Version:

- LD = Line driver RS422
- IX = LD with Interpolation
- KS = Push-pull with short-circuit protection
- TL = TTL compatible
- OC = Open collector
- KI = KS and inverted signals
- HL = HTL compatible

#### Version:

- QI = 11 μApp at 1 kOhm load
- SI = 1 Vpp at 120 Ohm load

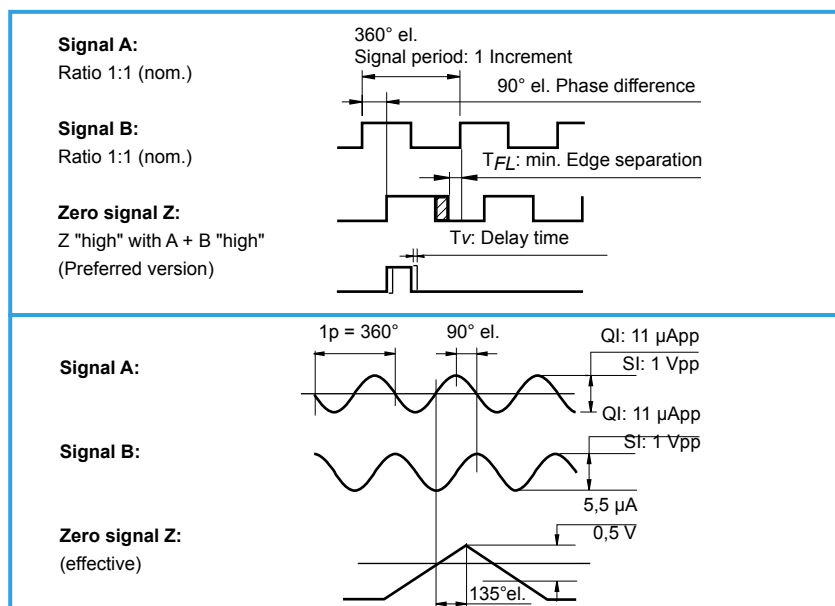

LTN Servotechnik GmbH

### Connector-Terminal and Cable Designation

G 58	Output circuit			
	OC / TL / HL / KS		LD / IX (RS422) / KI	
Function / Signal	12-pin	cable Pur 12 x 0,19	12-pin	cable Pur 12 x 0,19
Signal A	5	brown	5	brown
Signal $\bar{A}$	-	-	6	green
Signal B	8	grey	8	grey
Signal $\bar{B}$	-	-	1	pink
Signal Z	3	red	3	red
Signal $\bar{Z}$	-	-	4	black
V <sub>CC</sub>	12	blue	12	blue
V <sub>CC Sense</sub>	2	violet	2	violet
0 Volts	10	white	10	white
0 Volts <sub>Sense</sub>	11	yellow	11	yellow
Shield	9	white-blue	9	white-blue

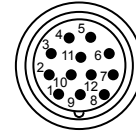
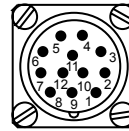

**Square flange receptacle 12-pin:**  
RC-12P2N122K00

**Pin plug 12-pin:**  
Metal: RC-12P2N1280EF  
Plastic: RC-12P1N12K0EF

**Mating connector 12-pol:**

Socket plug for square  
flange receptacle:  
RC-12S2N1280EF

**Socket coupling  
for pin plug:**

Metal: RC-12S1N1290EF  
Plastic: RC-12S1N12M0EF

G 58	Output circuit			
	QI		SI	
Function / Signal	9-pin	cable Pur 8 x 0,14	12-pin	cable Pur 12 x 0,19
Signal A +	1	green	5	brown
Signal A -	2	yellow	6	green
Signal B +	5	blue	8	grey
Signal B -	6	red	1	pink
Signal Z +	7	grey	3	red
Signal Z -	8	pink	4	black
V <sub>CC</sub>	3	brown	12	blue
V <sub>CC Sense</sub>	-	-	2	violet
0 Volts	4	white	10	white
0 Volts <sub>Sense</sub>	-	-	11	yellow
Shield	9	white-blue	9	Case
External shield	-	Case		

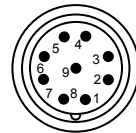
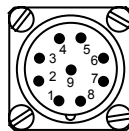

**Square flange receptacle 9-pin:**  
RC-09P1N122K00

**Pin plug 9-pin:**  
Metal: RC-09P1N1280EF  
Plastic: RC-09P2N12K0EF

**Mating connector 12-pol:**

Socket plug for square  
flange receptacle:  
RC-09S1N1280EF

**Socket coupling  
for pin plug:**

Metal: RC-09S2N1290EF  
Plastic: RC-09S2N12M0EF

LTN Servotechnik GmbH

### Recommended input circuitry of subsequent electronics LD and IX: Line driver RS 422 A

Operating voltage: 5 V ± 5 % or 8 ... 30 V  
 Current requirement: max. 180 mA (without load)  
 Output signals: A,  $\bar{A}$ , B,  $\bar{B}$ , Z,  $\bar{Z}$   
 Max. output frequency: 300 kHz for LD  
 400 kHz for IX  
  
 Min. edge separation:  $TFL \geq 0,25 \mu s$  (400 kHz)  
 Level (RS422):  $VH \geq 2,5 V$  ( $IH = -20 mA$ )  
 $VL \leq 0,5 V$  ( $IL = 20 mA$ )  
 Max. current load cap.:  $I_{max}: \pm 20 mA$  per output  
 Delay time:  $TV \leq 50 ns$   
 Switching times: rise / fall times:  $\leq 100 ns$   
 Cable length: max. 100 m  
 Operating temperature:  $-10^\circ C \dots +80^\circ C$

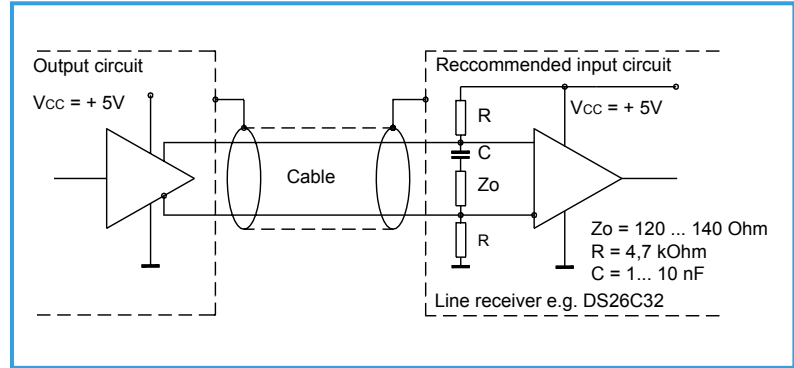

### KI, HL, KS: Push pull output with short-circuit protection

Operating voltage: 8 ... 30 V  
 Current requirement: max. 180 mA (without load)  
 Output signals: A, B, Z  
 max. output frequency: 200 kHz  
  
 Min. edge separation:  $TFL \geq 0,9 \mu s$   
 Max. current load cap.:  $I_{max}: 50 mA$  per output  
 Delay time:  $TV \leq 400 ns$   
 Switching times: rise / fall times:  $\leq 350 ns$   
 (1 m cable and  $I_{out} = 50 mA$ )  
 Cable length: max. 50 m  
 Operating temperature:  $-10^\circ C \dots +80^\circ C$   
 Short-circuit protection only at zero speed !

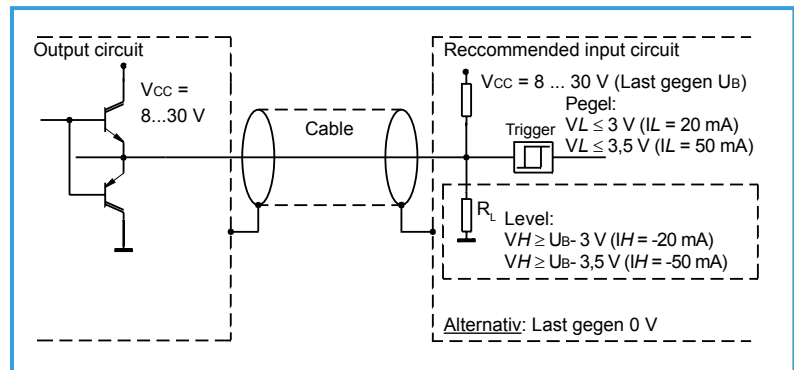

### QI: Current interface 11 $\mu App$

Operating voltage: 5 V ± 5 %  
 Current requirement: max. 100 mA  
 Output signals: A+, A-, B+, B-, Z+, Z-  
  
 Limit frequency (-3dB): max. 160 kHz  
  
 Signal level at a load of 1 kOhm: track signals: A, B  $\geq 11 \mu App$  (7 ... 16  $\mu App$ )  
 index signal (effective signal): Z  $\geq 5,5 \mu A$  (2 ... 8,5  $\mu A$ )  
  
 Cable length: max. 30 m  
  
 Operating temperature:  $-10^\circ C \dots +80^\circ C$

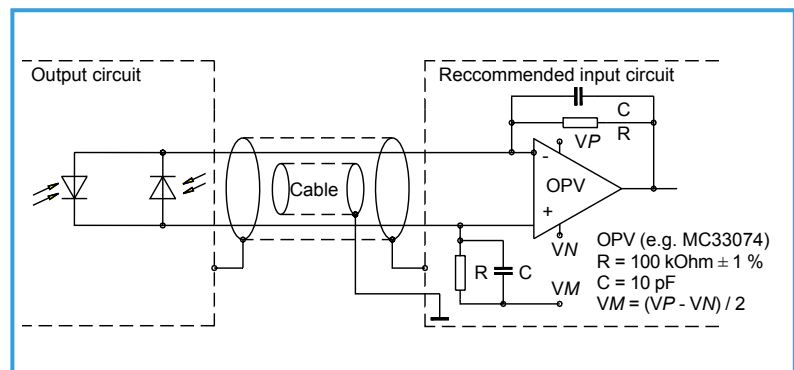

### SI: Voltage interface 1 Vpp

Operating voltage: 5 V ± 5 %  
 Current requirement: max. 180 mA  
  
 Output signals: A+, A-, B+, B-, Z+, Z-  
  
 Limit frequency (-3dB): max. 160 kHz  
  
 Signal level at a load of  $Z_o = 120 \text{ Ohm}$ : track signals: A, B  $\sim 1 Vpp$  (0,8 ... 1,2 Vpp)  
 index signal (effective signal): Z  $\sim 0,5 V$  (0,2 ... 0,85 V)  
  
 Cable length: max. 150 m  
  
 Operating temperature:  $-10^\circ C \dots +80^\circ C$

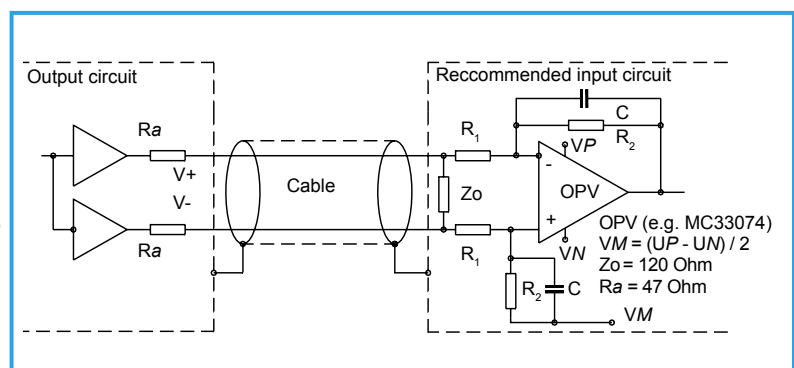

LTN Servotechnik GmbH

Ordering information	G	58	X	X	XX	XX	XXXX	-	X X X	-	XX																																																																															
	G	58	3	4	5.1	5.2	6	-	7 8 9	-	10																																																																															
<b>G</b>	<b>Incremental Rotary Encoder</b>																																																																																									
<b>58</b>	<b>Model series</b>																																																																																									
<b>3</b>	<b>Mechanical specification</b> S = Type S D = Type S + higher vibration capability L = Type L E = Type L + higher vibration capability H = Type H T = Type H + higher vibration capability W = Type W (shaft mounting with torque coupling) others upon request																																																																																									
<b>4</b>	<b>Shaft- or hollow shaft configuration</b> S = Standard 6 mm for G58L, G58S S = Standard 10 mm for G58H S = Standard 6 mm for G58W T = 8 mm for G58W U = 10 mm for G58W, G58L, G58S V = 12 mm for G58W Q = 14 mm for G58W others upon request																																																																																									
<b>5.1</b>	<b>Output circuit</b> LD = Line driver; RS422 IX = LD with interpolation KS = Push-pull with short-circuit protection KI = KS and inverted signals TL = TTL compatible OC = Open collector QI = Current interface 11 µApp at 1 kOhm load SI = Voltage interface 1 Vss at 120 Ohm load HL = HTL compatible (8 - 30 V in and out)																																																																																									
<b>5.2</b>	<b>Output channels</b> BI = channel A and B IN = channel B only others upon request																																																																																									
<b>6</b>	<b>Line counts</b> <table border="1"> <tr> <td>2</td><td>8</td><td>10</td><td>25</td><td>50</td><td>64</td><td>100</td><td>120</td><td>125</td><td>128</td><td>150</td><td>160</td><td>180</td> </tr> <tr> <td>190</td><td>200</td><td>240</td><td>250</td><td>254</td><td>256</td><td>300</td><td>350</td><td>360</td><td>380</td><td>400</td><td>500</td><td>512</td> </tr> <tr> <td>560</td><td>600</td><td>604</td><td>625</td><td>635</td><td>676</td><td>720</td><td>750</td><td>800</td><td>900</td><td>1000</td><td>1024</td><td>1125</td> </tr> <tr> <td>1130</td><td>1152</td><td>1200</td><td>1250</td><td>1270</td><td>1440</td><td>1500</td><td>1600</td><td>1800</td><td>2000</td><td>2048</td><td>2160</td><td>2164</td> </tr> <tr> <td>2200</td><td>2400</td><td>2500</td><td>2540</td><td>2592</td><td>2670</td><td>3000</td><td>3092</td><td>3142</td><td>3600</td><td>3927</td><td>4000</td><td>4096</td> </tr> <tr> <td>4490</td><td>5000</td><td>5760</td><td>8192</td><td>9000</td><td>10000</td><td colspan="6"></td><td colspan="2">others upon request</td> </tr> </table>											2	8	10	25	50	64	100	120	125	128	150	160	180	190	200	240	250	254	256	300	350	360	380	400	500	512	560	600	604	625	635	676	720	750	800	900	1000	1024	1125	1130	1152	1200	1250	1270	1440	1500	1600	1800	2000	2048	2160	2164	2200	2400	2500	2540	2592	2670	3000	3092	3142	3600	3927	4000	4096	4490	5000	5760	8192	9000	10000							others upon request	
2	8	10	25	50	64	100	120	125	128	150	160	180																																																																														
190	200	240	250	254	256	300	350	360	380	400	500	512																																																																														
560	600	604	625	635	676	720	750	800	900	1000	1024	1125																																																																														
1130	1152	1200	1250	1270	1440	1500	1600	1800	2000	2048	2160	2164																																																																														
2200	2400	2500	2540	2592	2670	3000	3092	3142	3600	3927	4000	4096																																																																														
4490	5000	5760	8192	9000	10000							others upon request																																																																														
<b>7</b>	<b>Zero index Z</b> 1 = Z „high“ if A „high“ 5 = Z „high“ if A + B „high“ others upon request																																																																																									
<b>8</b>	<b>Flange</b> 2 = Servo (G58L and G58S) 3 = round 5 = round sealed bearing 7 = round + shaft seal (G58L and G58S) others upon request																																																																																									
<b>9</b>	<b>Connector or cable output</b> 0 = connector axial 1 = connector radial 2 = cable axial (1m) 3 = cable radial (1m) 4 = cable radial with connector 5 = cable axial with connector 6 = leads axial 7 = leads radial others upon request																																																																																									
<b>10</b>	<b>Supply voltage</b> 05 = 5 Volts 24 = 8 ... 30 Volts																																																																																									

**İMAJ TEKNİK ELEKTRİK ELEKTRONİK MALZEMELERİ SAN. VE TİC. LTD. ŞTİ.**

Emekyemez Mah. Yüksek Minare Sk. No:8 / 17 80020 Karaköy / İstanbul  
 T.: +90 212 235 95 35 / 36 F.: +90 212 235 95 37 info@imajteknik.com

[www.imajteknik.com](http://www.imajteknik.com) - [www.imajteknik.com.tr](http://www.imajteknik.com.tr)

