

Incremental Rotary Encoder G1B



- Housing diameter: 130 mm
- Hollow shaft: 25.4 ... 60 mm
- Line counts: 64 ... 8192
- Output signals: RS422, KS, KI, 1Vpp
- Connector or cable output

Mechanical Data

G1B	Hollow shaft Type W
Hollow shaft	25.4, 28, 32, 38, 42, 45, 48, 50, 60 mm
Weight	ca. 1100 g
Accuracy (up to line count 2500)	$< \pm \frac{360^\circ}{\text{Line counts} \times 20}$
Mech. permissible speed	max. 3.500 min ⁻¹
Starting torque (25°C)	< 0,5 Nm
Rotor inertia (depends on the specific Version)	1,1 * 10 ⁻³ kgm ² ... 1,6 * 10 ⁻³ kgm ²
Vibration	100 m/s ² ; higher upon request
Shock	1000 m/s ² ; higher upon request
Operating temperature	-25°C ... +85°C; -40°C ... +100°C upon request for KS or KI: RS 422
Protection class	IP 64

Line counts

64	1024	2048	2500	4096	8192	others upon request
----	------	------	------	------	------	---------------------

LTN Servotechnik GmbH

Dimensions (mm)

- Standard: IP 64 (with sealing ring)
- connector or cable output radial
- optional: second torque coupling
- axial backlash (shaft): max. $\pm 1,5$ mm
- ② set screw 6 x M3; SW 1,5 included

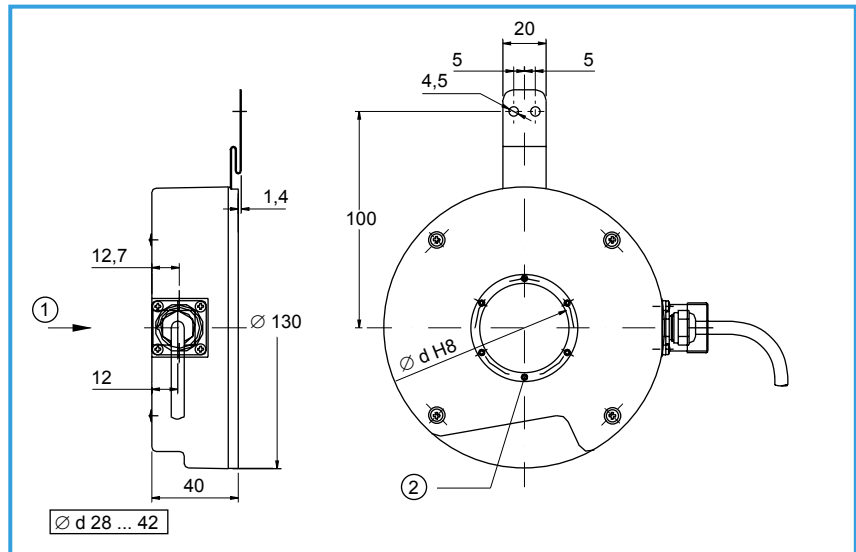

- Standard: IP 64 (with sealing ring)
- connector or cable output radial
- optional: second torque coupling
- axial backlash (shaft): max. $\pm 1,5$ mm
- ③ set screw 4 x M5; SW 2,5 included

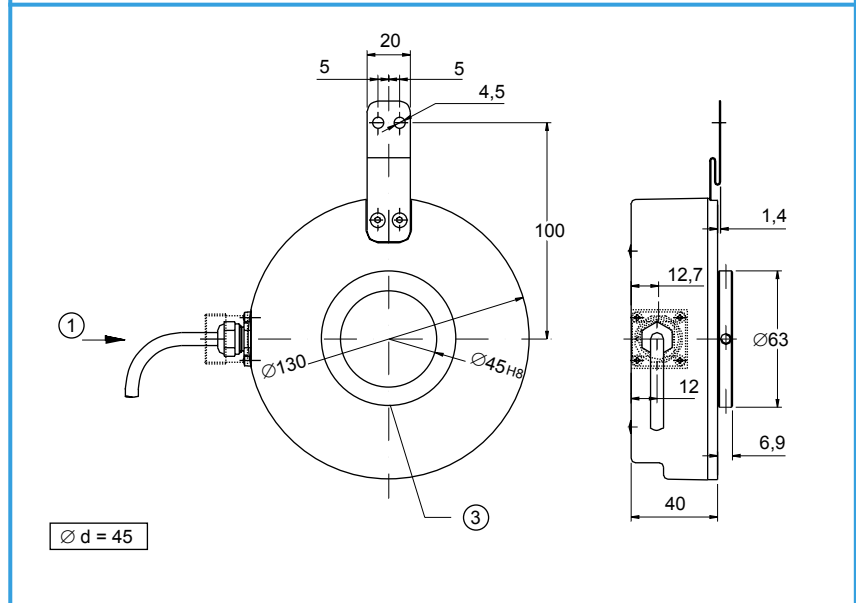

- Standard: IP 64 (with sealing ring)
- connector or cable output radial
- optional: second torque coupling
- axial backlash (shaft): max. $\pm 1,5$ mm
- ④ set screw 4 x M5; SW 2,5 included

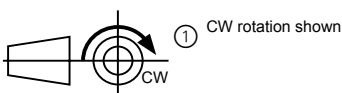
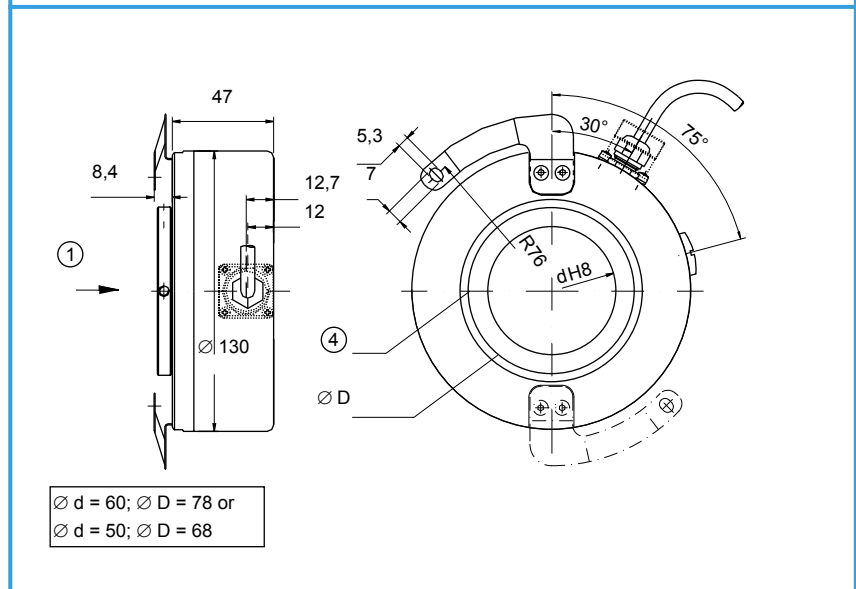

LTN Servotechnik GmbH

Electrical Data

Output signals	Supply voltage	Output voltage	Current requirements	Output load	Output frequency	Cable length	Zero index
LD (RS422)	5 V	5 V	max. 70 mA	± 20 mA	0 .. 300 kHz	max. 100 m	1)
	8 .. 30 V	5 V					1)
KI / KS	8 .. 30 V	8 .. 30 V	max. 70 mA	20 mA	0 .. 160 kHz	max. 50 m	1)
SI	5 V	5 V	max. 70 mA	8 mA (bei 120 Ω)	0 .. 180 kHz	max. 150 m	1)

1) 5 = Z "high" if A + B "high"

Output Signals

Version:

LD = Line driver RS422

KS = Push pull with short-circuit protection

KI = KS with inverted signals

Version:

SI = 1 Vpp at 120 Ohm load

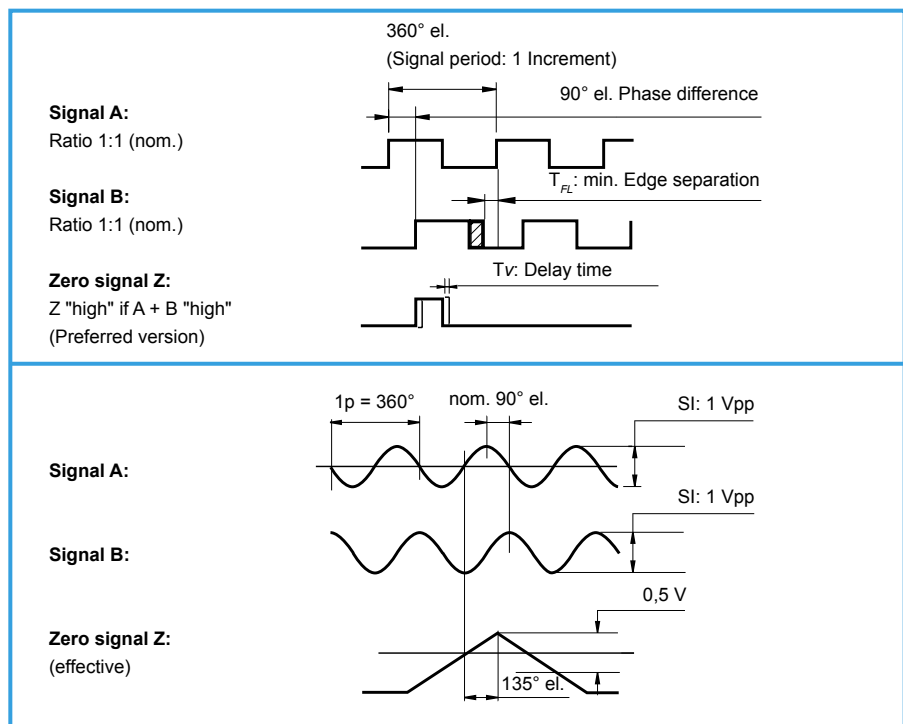

LTN Servotechnik GmbH

Connector-Terminal and Cable Designation

G1BW	Output circuit			
	KS		LD / KI	
Function / Signal	12-pin	Cable Pur 12 x 0,19	12-pin	Cable Pur 12 x 0,19
Signal A	5	brown	5	brown
Signal \bar{A}	-	-	6	green
Signal B	8	grey	8	grey
Signal \bar{B}	-	-	1	pink
Signal Z	3	red	3	red
Signal \bar{Z}	-	-	4	black
V _{CC}	12	blue	12	blue
V _{CC Sense}	2	violet	2	violet
0 Volts	10	white	10	white
0 Volts _{Sense}	11	yellow	11	yellow
Shield	9	white-blue	9	white-blue

G1BW	Output circuit	
	SI	
Function / Signal	12-pin	Cable Pur 12 x 0,19
Signal A +	5	brown
Signal A -	6	green
Signal B +	8	grey
Signal B -	1	pink
Signal Z +	3	red
Signal Z -	4	black
V _{CC}	12	blue
V _{CC Sense}	2	violet
0 Volts	10	white
0 Volts _{Sense}	11	yellow
Shield	9	white-blue

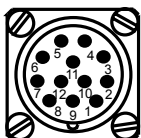

Square flange receptacle 12-pin:
RC-12P2N122K00

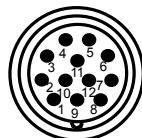

Pin plug 12-pin:
Metal: RC-12P2N1280EF
Plastic: RC-12P1N12K0EF

Mating connector 12-polig:

Socket plug for
square flange receptacle:
RC-12S2N1280EF

**Socket coupling
for pin plug:**

Metal: RC-12S1N1290EF
Plastic: RC-12S1N12M0EF

LTN Servotechnik GmbH

Recommended input circuitry of subsequent electronics

LD: Line driver RS 422 A

Operating voltage: 5 V ± 5 % or 8 ... 30 V
 Current requirement: max. 70 mA (without load)
 Output signals: A, \bar{A} , B, \bar{B} , Z, \bar{Z}
 Max. output frequency: 300 kHz
 Min. edge separation: TFL ≥ 0,25 μs
 Level (RS422): VH ≥ 2,5 V (IH = -20 mA)
 VL ≤ 0,5 V (IL = 20 mA)
 Max. current load cap.: I_{max}: ±20 mA per output
 Delay time: TV ≤ 50 ns
 Switching times: rise / fall times: ≤ 100 ns
 Cable length: max. 100 m
 Operating temperature: -25 °C ... +85 °C

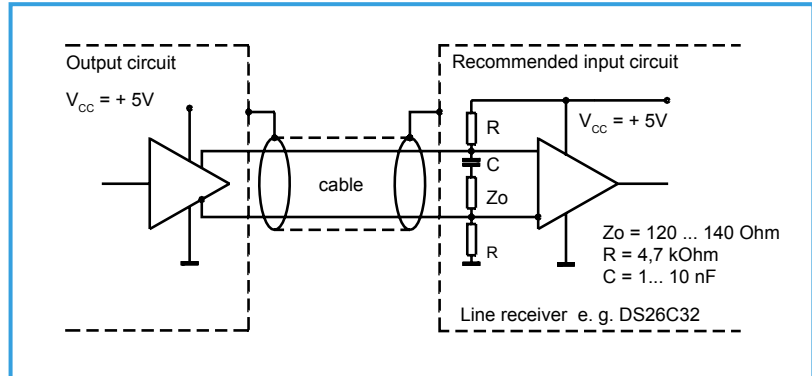

KS, KI: Push pull output with short-circuit protection

Operating voltage: 8 ... 30 V
 Current requirement: max. 70 mA (without load)
 Output signals: A, B, Z
 Max. output frequency: 160 kHz
 Min. edge separation: TFL ≥ 0,9 μs
 Max. current load cap.: I_{max}: 20 mA per output
 Delay time: TV ≤ 400 ns
 Switching times: rise / fall times: ≤ 350 ns
 (1 m cable and I_{out} = 50 mA)
 Cable length: max. 50 m
 Operating temperature: -25 °C ... +85 °C
 Short-circuit protection only at zero speed !

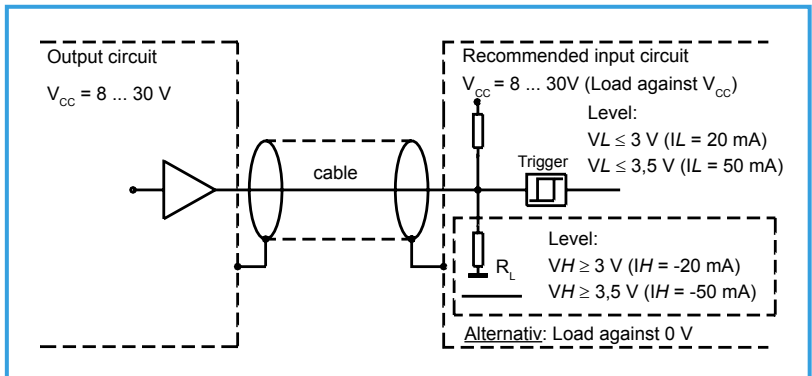

SI: Voltage interface 1 Vpp

Operating voltage: 5 V ± 5 %
 Current requirement: max. 70 mA
 Output signals: A+, A-, B+, B-, Z+, Z-
 Limit frequency (-3dB): max. 180 kHz
 Signal level at a load of Zo = 120 Ohm:
 track signals: A, B ~ 1 V (0,8 ... 1,2 V)
 index signal (effective signal): Z ~ 0,5 V (0,2 ... 0,85 V)
 Cable length: max. 150 m
 Operating temperature: -25 °C ... +85 °C

