

Optical Data Transmission Device

DMH-GB/HB

DMH series is a DMS-G/H series with high-speed communication. This is approx. 5 times faster than DMS-G/H series and can communicate more data in specific time.

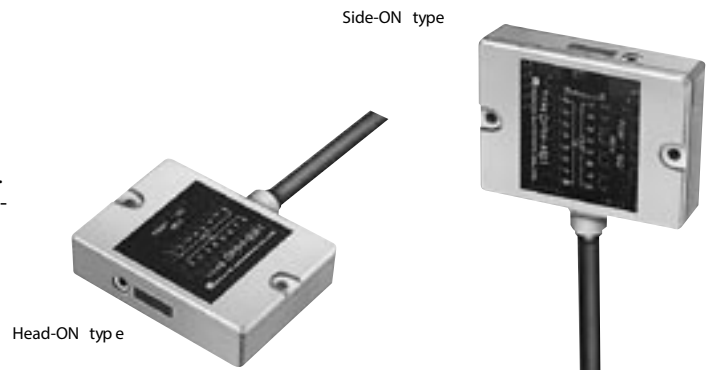

Specifications

Type	Parallel type			
	DMH-GB1	DMH-GB2	DMH-HB1	DMH-HB2
Model				
Direction	Head-on		Side-on	
Transmission distance(Max.)	0.6 m	3m	0.5 m	3m
Directional angle	$\pm 15^\circ$	$\pm 5^\circ$	$\pm 15^\circ$	$\pm 5^\circ$
Transmission capacity	8BIT			
Transmission method	Half duplex two-way transmission			
Transmission time	7msec			
Modulation method	FSK modulation			
Detection method	bit-reverse comparing system			
Power source	18V to 30VDC (ripple 10 % or less)			
Current consumption	100mA or less			
Ambient illuminance	10,000lux or less			
Ambient temperature/humidity	-10 to +50 , 85%RH or less			
Connection	Lead wire (0.2mm ² 26 cores shield wire in 2m)			
Protective structure	IP64 (IEC Standard)			
Case material	ABS resin(Display: acrylic resin)			
Weight	Approx. 250 g			

Input/Output circuit

Input section

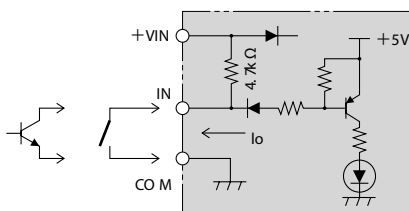

Flow current(I_o) when ON : approx. 5mA(When 24 VDC)
Allowable residual voltage: Use with 1.8V or less.

Output section

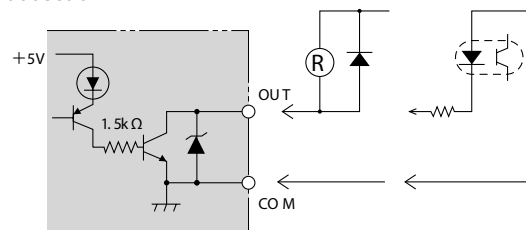

NPN open-collector output
35V DC 50mA Residual voltage 1.5V or less.

External dimensions

Head-on type

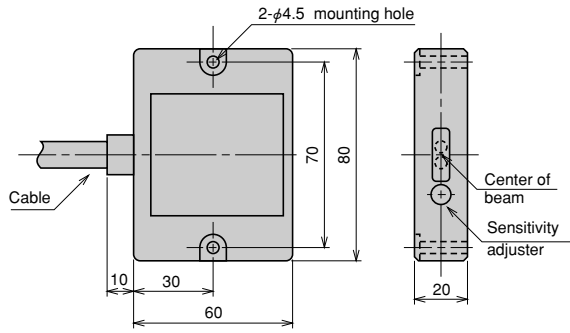

Side-on type

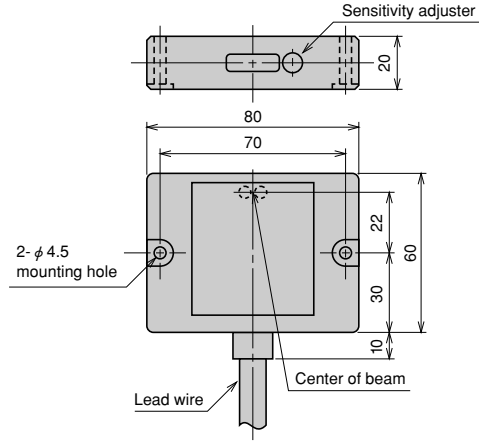

Connection

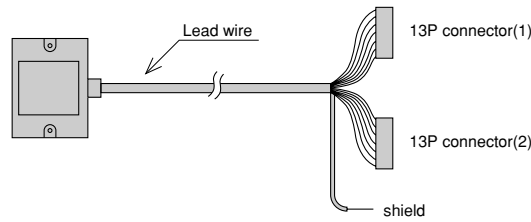

Connector(1)		
Lead wire	Pin No.	Spec.
Light blue	1	Power 0V
Pink	2	Power +V
White	3	IN1
White/Black	4	IN2
Brown	5	IN3
Brown/Black	6	IN4
Red	7	IN5
Red/Black	8	IN6
Orange	9	IN7
Orange/Black	10	IN8
Yellow	11	IN4
Yellow/Black	12	MODE*1
Green	13	SELECT*2

Connector(2)		
Lead wire	Pin No.	Spec.
Green/Black	1	GO*3
Blue	2	Strobe*4
Blue/Black	3	(BSY)
Purple	4	OUT8
Purple/Black	5	OUT7
Gray/Black	6	OUT6
Gray/Black	7	OUT5
Pink/Black	8	OUT4
Light blue/Black	9	OUT3
Pink/Red	10	OUT2
Yellow/Red	11	OUT1
Light blue/Red	12	(M/S)
White/Red	13	(RDY)
Shield		Shield

Note) Don't use (BSY), (M/S)and(RDY).

Note) The connector attached can't be used as relay terminal.

***1. Mode input**

- This is designed to select standby transmission and reception mode.
- Transmission standby mode when it is opened between MODE and I/O COM.
- Reception standby mode when it is short circuited between MODE and I/O COM.

***2. Select input**

- This is designed to arbitrarily stop transmission and reception operation by outside signal.
- Operates when it is opened between SELECT and I/O COM.
- Stops operation when it is short circuited between SELECT and I/O COM.

***3. GO output**

- This is designed to check for correct reception of optical signal.
- it is ON when optical signal is received.
- it is OFF when optical signal is interrupted(or non-receiving state).

***4. Strobe**

- It is getting ON when data is fixed.