

## DB-2021S

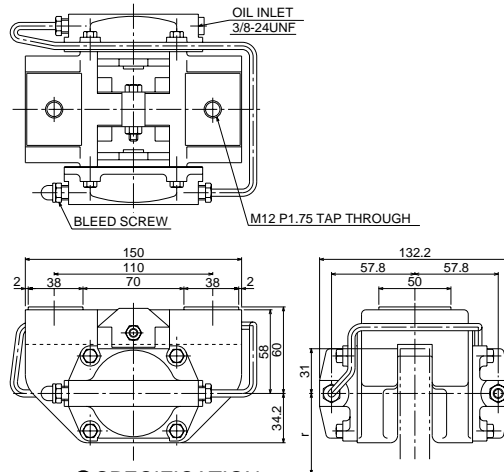

### ● CHARACTERISTIC CURVE

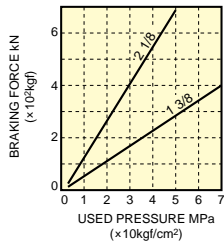

· COEFFICIENT OF DYNAMIC FRICTION 0.3

### ● SPECIFICATION

	DB-2021S	
· MODEL TYPE	DB-2021S	
· SIZE OF CYLINDER	1 3/8	2 1/8
· AREA OF CYLINDER (cm <sup>2</sup> )	9.57	22.88
· USABLE DISC DIA (mm)	φ222-∞	
· DISC THICKNESS (mm)	20	
· EFFECTIVE RADIUS OF BRAKING (m)	$r = \frac{1}{1000} \left( \frac{\text{DISC DIA}}{2} - 31 \right)$	
· PAD MODEL TYPE	DB-0400-K ※※※	
· WEAR ALLOWANCE OF PAD (mm)	10	
· MAX. WORKING OIL PRESSURE (MPa)	7 (70kgf/cm <sup>2</sup> )	5 (50kgf/cm <sup>2</sup> )
· REQUIRED OIL VOLUME (cc)	1	2.5
· WEIGHT (kg)	5	5.3
· TORQUE CALCULATION (BRAKING FORCE=kN)	T (kN-m) = kN × r	

Oil to be used: Use Brake Oil (Vegetable Oil). Also Brake for Mineral Oil are Available. High μ pad available.

6

## DB-2051

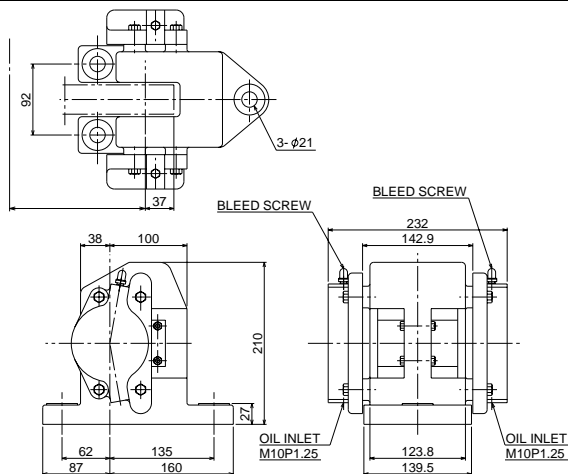

### ● CHARACTERISTIC CURVE

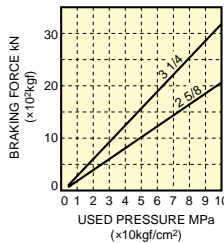

· COEFFICIENT OF DYNAMIC FRICTION 0.3

### ● SPECIFICATION

	DB-2051	
· MODEL TYPE	DB-2051	
· SIZE OF CYLINDER	2 5/8	3 1/4
· AREA OF CYLINDER (cm <sup>2</sup> )	34.89	53.49
· USABLE DISC DIA (mm)	φ380-∞	
· DISC THICKNESS (mm)	38	
· EFFECTIVE RADIUS OF BRAKING (m)	$r = \frac{1}{1000} \left( \frac{\text{DISC DIA}}{2} - 37 \right)$	
· PAD MODEL TYPE	DB-0401-K ※※※	
· WEAR ALLOWANCE OF PAD (mm)	18	
· MAX. WORKING OIL PRESSURE (MPa)	10 (100kgf/cm <sup>2</sup> )	
· REQUIRED OIL VOLUME (cc)	7	10
· WEIGHT (kg)	24	
· TORQUE CALCULATION (BRAKING FORCE=kN)	T (kN-m) = kN × r	

Oil to be used: Use Brake Oil (Vegetable Oil). Also Brake for Mineral Oil are Available. High μ pad available.

· Dimensions and specifications might be changed for improvement without notice.