

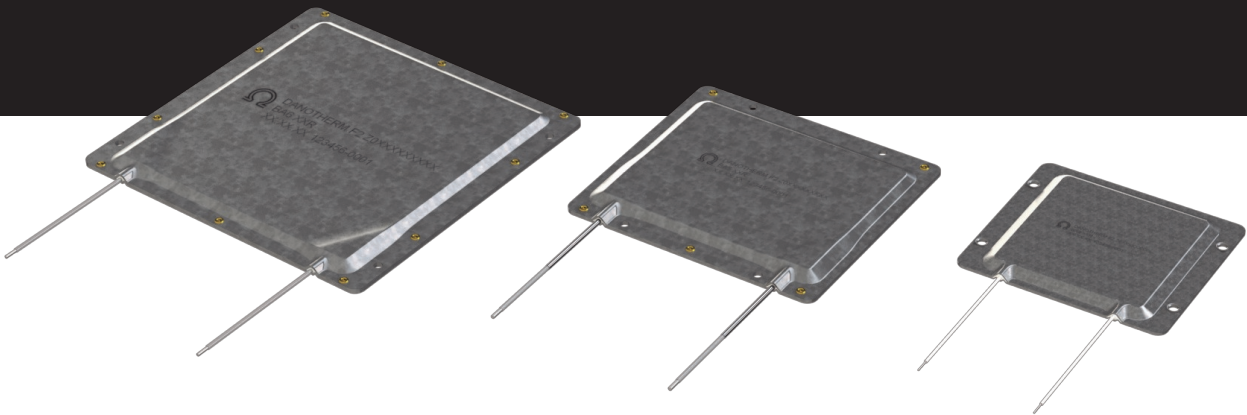

DANOTHERM™



BI-ALPHA

- Compact Power resistors (forced air cooled)

- Extreme compact design
- Cost effective
- Easy implementation
- Fully insulated; no external live parts
- Low thermal drift, 100ppm

Construction

The resistors are designed as follows:

The resistor elements are wire wound on a mica substrate. This substrate is insulated by two mica sheets to assure the minimum voltage breakdown. The housing is made from aluminium zinc alloy with good thermal properties. The standard cables are 300 mm AWG 18 600V. We can supply cables in specified lengths and mounted with cable shoes or connectors as required.

Simulations

The start for each resistor selection is a power-time graph from your application. Danotherm is able to predict the temperature of the resistor by using sophisticated models.

Pulse load

The ability to withstand pulse loads varies per resistor size, wire length and wire diameter. As such, it is impossible to create standard graphs that would apply for most customers applications.

At your request Danotherm performs the simulation for you based on your application.

The table shown is based on a resistor with a wire of 0.3mm. For different duty times the maximum power is noted with a repetition time of 120 seconds. The table is only valid for mentioned wire diameter. With each ohm value a different model and different pulse loads apply.

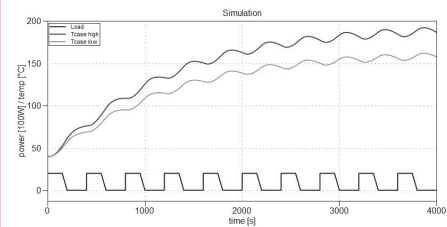
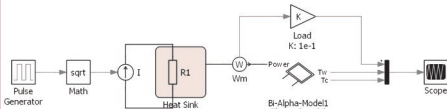

Type Bi-Alpha	P _N [W] @40°C air 2m/s	Surface temp. [°C] @40°C	Pulse load during x each 120 seconds [W] @ 40°C					R [Ω] standard ± 10% on request ± 5%
			1s (0.8%)	2s (1.7%)	5s (4.1%)	10s (8.3%)	40s (33%)	
size 4	45	250	950	500	230	140	75	6 - 600
size 5	100	250	2500	1400	700	480	260	40 - 1500
size 6	175	250	4600	2500	1200	760	460	20 - 2500

General specifications		
Temperature Coefficient:		< ± 100 ppm
Dielectric strength	standard	2500 VAC @ 1 minute
Working voltage	standard	600 VAC / 850 VDC
Insulation Resistance:		> 20 MΩ
Overload:@ 1 sec pulse / hour		20 - 25 x (depending on resistance)
Overload:@ 5 sec pulse / hour		5 - 7 x (depending on resistance)
Cooling:		air 2m/s
Environmental:		- 40 °C - 90 °C
De-rating:		Linear: 40 °C = P _n to 70 °C = 0,65 * P _n

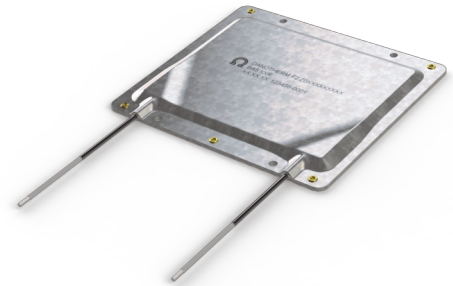
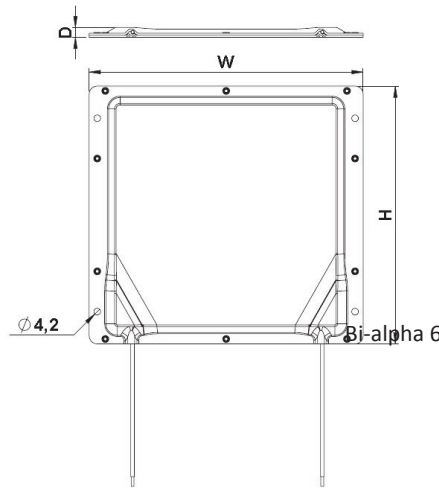
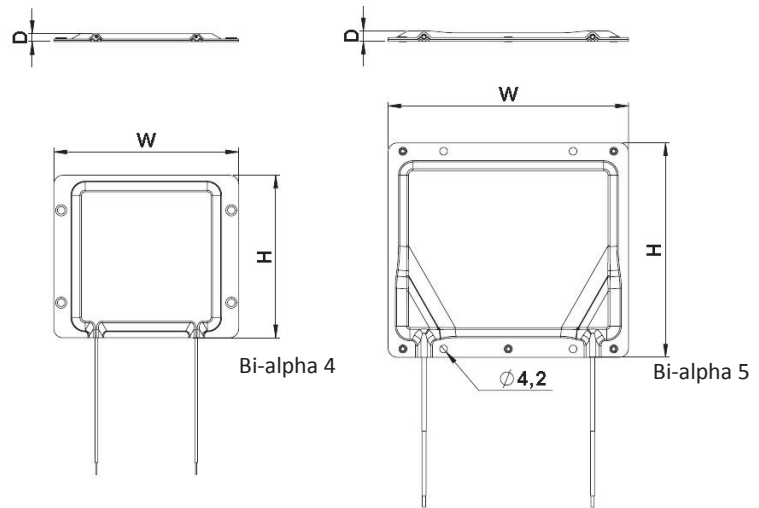

Bi-Alpha	W	H	D	weight
	[mm]			[g]
size 4	100	88	4,3	94
size 5	130	116	4,6	240
size 6	170	160	5,25	540

DAN EN13.5011R3

19062017



Danotherm Electric A/S
Naesbyvej 20
2610 Roedovre
Denmark

www.danotherm.com
CVR 1012 6061